

UWL REPOSITORY
repository.uwl.ac.uk

Impact of the uses of various technologies on the thermal performance and energy efficiency of UK hotel buildings: application to Hilton hotels in the UK

Rotimi, Abdulazeez (2018) Impact of the uses of various technologies on the thermal performance and energy efficiency of UK hotel buildings: application to Hilton hotels in the UK. Doctoral thesis, University of West London.

This is the Accepted Version of the final output.

UWL repository link: <https://repository.uwl.ac.uk/id/eprint/6271/>

Alternative formats: If you require this document in an alternative format, please contact: open.research@uwl.ac.uk

Copyright:

Copyright and moral rights for the publications made accessible in the public portal are retained by the authors and/or other copyright owners and it is a condition of accessing publications that users recognise and abide by the legal requirements associated with these rights.

Take down policy: If you believe that this document breaches copyright, please contact us at open.research@uwl.ac.uk providing details, and we will remove access to the work immediately and investigate your claim.

**Impact of the Uses of Various Technologies on the Thermal
Performance and Energy Efficiency of UK Hotel Buildings:
Application to Hilton Hotels in the UK**

Abdulazeez Juwon Rotimi

*A thesis submitted to the University of West London in partial fulfilment
of the requirements for the degree of
Doctor of Philosophy*

School of Computing and Engineering

University of West London,

United Kingdom

October 2018

Abstract

A substantial reduction in the amount of carbon dioxide emissions resulting from human activities is required to curb global warming and this has led to the development of numerous measures to ensure that cleaner and more efficient energy sources are utilised in all facets of people's daily lives.

Globally, buildings account for almost half of the energy use in both developed and developing nations. Commercial buildings account for a sizeable proportion of this building energy consumption and this trend will probably continue to increase. Therefore, concerted efforts are currently being directed at the development and application of effective building strategies and measures to improve energy efficiency in buildings.

This study evaluates the impact of various energy efficiency measures and technologies on the thermal and energy performance of UK hotel buildings using a whole building dynamic simulation software (application to Hilton hotels) with a focus on the knock-on effects that these technologies will have on the overall energy performance and efficiency of UK hotels, either installed individually or in various combinations. The study employs a quantitative research approach underpinned by the thermal analysis simulation of various case study hotel buildings to address the supposition that dynamic climatic conditions, building energy consumption estimates, building energy efficiency improvement strategies and building thermal behaviour can be appropriately simulated to enhance the energy efficiency of commercial buildings and abate the unfavourable effects of global climate change.

The outcome of the research presents a practical approach of estimating the energy consumption of operational hotel buildings with relative accuracy aimed at testing the suitability of various

energy improvement measures. The research also demonstrates that holistic consideration, design and retrofitting of different types of building façade energy improvement measures such as enhanced glazing and window properties and appropriate ventilation of double-skin-façades can improve the thermal and energy performance of existing hotel buildings. Additionally, the research results established that retrofit Combined Heat and Power (CHP) in relatively large hotels, either sized maximally or with reduced capacity of more than half of the maximum size, can provide sizeable environmental and economic benefits. However, results of the evaluation of the current decarbonisation of the UK power grid indicate that the environmental benefits of fossil fuel powered CHP become less pronounced for the future grid projections. Moreover, optimum CHP size design can be obtained via evaluation of the relationship between the core building performance parameters and their variation with CHP sizes.

Declaration of Authorship

I, Abdulazeez Rotimi, declare that this thesis entitled, 'Impact of the Uses of Various Technologies on the Thermal Performance and Energy Efficiency of UK Hotel Buildings: Application to Hilton Hotels in the UK and the work presented in it are my own. I confirm that:

- This work was done wholly or mainly while in candidature for a research degree at this University.
- Where any part of this thesis has previously been submitted for a degree or any other qualification at this University or any other institution, this has been clearly stated.
- Where I have consulted the published work of others, this is always clearly attributed.
- Where I have quoted from the work of others, the source is always given. With the exception of such quotations, this thesis is entirely my own work.
- I have acknowledged all main sources of help.
- Where the thesis is based on work done by myself jointly with others, I have made clear exactly what was done by others and what I have contributed myself.
- Parts of this work have been published, or are currently under review to be published, as journal papers.

Signed:

Date:

Table of Contents

Abstract.....	i
Declaration of Authorship.....	iii
List of Figures.....	viii
List of Tables	xiii
List of Acronyms/Abbreviations.....	xv
Acknowledgements	xxii
List of Published and Submitted Journal Papers	xxiii
Chapter 1: General Introduction.....	1
1.1 Background.....	1
1.2 Aim	5
1.3 Identified knowledge gap.....	6
1.4 Objectives	7
1.5 Motivation and research questions.....	10
1.6 Thesis outline and chapter layout.....	11
Chapter 2: Literature Review	15
2.1 CO ₂ Emission Reduction and Energy Consumption	15
2.2 Energy Efficiency and CO ₂ Emission Reduction in Buildings	20
2.3 Building Modelling and Simulation.....	23
2.3.1 Building energy performance modelling for compliance and actual energy consumption estimation.....	27
2.3.2 Studies on performance gap and estimation of building energy performance	30
2.4 Measures of Improving Building Energy Performance	36
2.5 Building Façade and Window Glazing	37
2.5.1 Studies on the impact of window glazing and glazing energy improvement measures.....	40
2.5.2 Studies on the impact of glazed building façades on building energy performance	47
2.6 Combined Heat and Power (CHP).....	51
2.6.1 Definition of CHP	52
2.6.2 Types of CHP and applications.....	54
2.6.3 CHP financing.....	58
2.6.4 Benefits of CHP	61
2.6.5 UK Grid Decarbonisation and Air quality	63
2.6.6 Studies on performance and application of CHP Systems in efficient energy production	68
Chapter 3: Methodology.....	75

3.1	Research Paradigm.....	75
3.2	Research Design.....	76
3.3	Ethical Considerations	77
3.4	Building simulation methodology.....	78
3.4.1	CIBSE TM 54 Methodology.....	82
3.5	Selection of Simulation Tool	86
3.5.1	TAS building simulation software	88
3.6	TAS Building Simulation Principle	89
3.7	EDSL TAS 3D Modelling Process	92
3.8	Thermal Simulation Process	94
3.9	Plant/systems Modelling.....	96
3.10	UK Building Regulation Model.....	97
Chapter 4: Estimation and Validation of Energy Consumption in Existing Hotel Buildings in the UK Using Dynamic Simulation Software.....		99
4.1	Introduction.....	99
4.2	Building Description.....	100
4.2.1	Building description for Hilton Reading Hotel.....	101
4.2.2	Building description for Hilton London Heathrow Airport Terminal 4.....	104
4.2.3	Building description for Hilton London Gatwick Airport Hotel.....	108
4.3	Study Method.....	112
4.3.1	3D modelling	113
4.3.2	Simulation process	114
4.4	Results and Discussion	126
4.4.1	Energy consumption and validation for Hilton Reading Hotel.....	126
4.4.2	Energy consumption and validation for Hilton London Heathrow Airport Terminal 4 and Hilton London Gatwick Airport.....	136
4.5	Summary and Conclusion	147
4.6	Recommendations.....	148
Chapter 5: Impact of Extraction Fans in the Cavity of the East and West Double Skin Facade on the Thermal and Energy Performance of Hilton London Heathrow Airport Terminal 4.....		149
5.1	Introduction.....	149
5.2	Building Description.....	151
5.3	Study Method.....	151
5.3.1	3D modelling	151
5.3.2	Simulation process	152

5.4	Results and Discussion of Results	154
5.4.1	Results of the impact of extraction fans in DSF cavity for the building model simulation in Edinburgh.....	174
5.5	Summary and Conclusion	185
Chapter 6: Impact of Window Films on the Energy Performance of Existing UK Hotel Buildings		187
6.1	Introduction.....	187
6.2	Building Description.....	188
6.3	Study Method.....	188
6.3.1	3D modelling	189
6.3.2	Simulation process	189
6.4	Results and Discussion for Impact of Window Films on Hilton Reading Hotel (Glazed Curtain Wall) 193	
6.4.1	Case study result with window films on all orientations of the building.....	193
6.4.2	Case study result for Hilton Reading Hotel with window films on different orientations of the building	216
6.5	Results and Discussion for Impact of Window Films on Hilton London Heathrow Airport Terminal 4 (Conventional framed structure and Wall)	219
6.5.1	Case study result with window films on all orientation of the building	220
6.6	Results and Discussion for the Impact of Window Films on Hilton Reading Hotel (Glazed Curtain Wall) Building Model Simulation in Edinburgh.....	231
6.7	Summary and Conclusion	240
Chapter 7: Optimum Size Selection of CHP Retrofitting in Existing UK Hotel Buildings.....		245
7.1	Introduction.....	245
7.2	Building Description.....	249
7.3	Case Study Method.....	249
7.3.1	3D modelling	250
7.3.2	Simulation process	250
7.4	Results and Discussion of Results	252
7.4.1	Base model (without CHP)	252
7.4.2	Model with maximum capacity of CHP.....	253
7.4.3	Model with CHP; 307kWe.....	259
7.5	Summary and Conclusion	271
Chapter 8: Conclusions and Recommendations		273
8.1	Chapter Summary	273

8.1.1	Case study 1: Estimation and validation of energy consumption in existing UK hotel buildings	274
8.1.2	Case Study 2: Effect of DSF and its cavity space ventilation on the thermal and overall energy of existing hotel buildings	275
8.1.3	Case study 3: Impact of window films on the energy performance of existing UK hotel buildings	277
8.1.4	Case study 4: Optimum size selection of CHP retrofitting in existing UK hotel building	278
8.2	Limitations of the Studies in this Research	279
8.3	Recommendations for Future Study	280
References		282

List of Figures

Figure 2.1: Use of common central model for multiple applications (CIBSE, 2015)	29
Figure 2.2: Case study result for Part L model and the TM54 estimates against actual measurement (CIBSE, 2013a).....	32
Figure 2.3: Typical CHP configuration (EPA, 2018)	53
Figure 2.4 UK Electricity generation trajectory by technology (BEIS 2018a).....	66
Figure 2.5: UK Grid emissions intensity (BEIS, 2018a)	68
Figure 3.1: Summary of the TM54 methodology for estimating the operational energy consumption at the design stage (CIBSE 2013a).....	84
Figure 3.2: Heat transfer mechanisms in a building (reproduced from EDSL, 2015b).....	90
Figure 3.3: Floor modelling process	93
Figure 3.4: Building thermal simulation process.....	95
Figure 3.5: TAS systems simulation process.....	96
Figure 3.6: TAS UK Building Regulation Studio Process	97
Figure 4.1: Architectural plan of Hilton Reading Hotel	103
Figure 4.2: Architectural plan of Hilton London Heathrow Airport Terminal 4 Hotel.....	107
Figure 4.3: Architectural plan of Hilton London Gatwick Airport hotel.....	111
Figure 4.4: Summary of case study methodology for building energy estimation and validation	125
Figure 4.5: Typical floor plan showing floor usage and allocation of zones (Hilton Reading) .	126
Figure 4.6: TAS 3D model of the building (Hilton Reading).....	127
Figure 4.7 Showing UK Building Regulation simulation results (Hilton Reading).....	128
Figure 4.8: Showing Plant/system simulation results (Hilton Reading).....	130
Figure 4.9: Showing system simulation + catering energy use results (Hilton Reading).....	132

Figure 4.10: Breakdown of annual energy consumption into natural gas and electricity (Hilton Reading).....	134
Figure 4.11: Showing systems simulation result + Catering energy use vs. Building Reg. vs. Actual building consumption (Hilton Reading)	135
Figure 4.12: Typical floor plan showing floor usage and allocation of zones (Hilton London Heathrow hotel)	137
Figure 4.13: TAS 3D model of the building (Hilton London Heathrow hotel).....	138
Figure 4.14: Energy performance result from plant/system simulation (Hilton London Heathrow hotel)	139
Figure:4.15: Annual systems simulation result + Catering energy use vs. Actual building consumption (Hilton London Heathrow hotel).....	141
Figure 4.16: Breakdown of annual energy consumption into natural gas and electricity (Hilton London Heathrow)	142
Figure 4.17: Typical floor plan showing floor usage and allocation of zones (Hilton London Gatwick Airport hotel).....	144
Figure 4.18: TAS 3D model of the building (Hilton London Gatwick Airport hotel)	144
Figure 4.19: Showing building performance result	146
Figure 5.1: Summary of case study methodology	153
Figure 5.2: Zoning of atrium and adjoining double skin façade.....	154
Figure 5.3: External temperature, DSF cavity temperature and Atrium temperature result without extraction fans vs. time (day, hour) throughout the year.	156
Figure 5.4: Difference in resultant temperature between the east DSF cavity and adjoining central atrium (without extract fan)	158
Figure 5.5: Difference in the resultant temperature between the west DSF cavity and adjoining central atrium (without an extract fan).....	158
Figure 5.6: DSF Cavity simulation result for a typical cold mostly cloudy day	160
Figure 5.7: DSF Cavity simulation result for a typical Hot sunny day.....	162

Figure 5.8: Temperature of thermal sensor installed in the east facing DSF cavity	163
Figure 5.9: DSF façade thermal sensor temperature reading vs DSF façade simulation temperature result.....	164
Figure 5.10: Resultant temperature difference between the DSF cavity and central atrium (with and without extraction fan)	166
Figure 5.11: The difference in resultant temperature in the central atrium space due to the effect of the extraction fan.....	168
Figure 5.12: Overall energy consumption result for simulation with and without extract fan...	170
Figure 5.13: Impact of DSF cavity extraction fan on the heating and cooling energy consumption	172
Figure 5.14: Annual overall energy consumption result (without extract fan vs. with extract fan vs extract fan in operation in summer only).....	174
Figure 5.15: External temperature of CIBSE London TRY weather data vs. CIBSE Edinburgh TRY weather data	175
Figure 5.16: External temperature, DSF cavity temperature and Atrium temperature result without extraction fans vs. time (day, hour) throughout the year (Edinburgh model).....	176
Figure 5.17: Difference in resultant temperature between the east DSF cavity and adjoining central atrium (Edinburgh model without extract fan)	178
Figure 5.18: Difference in the resultant temperature between the west DSF cavity and adjoining central atrium (Edinburgh model without an extract fan).....	178
Figure 5.19: DSF Cavity simulation result for a typical cold mostly cloudy day (Edinburgh model)	180
Figure 5.20: DSF Cavity simulation result for a typical Hot sunny day (Edinburgh model).....	182
Figure 5.21: Resultant temperature difference between the DSF cavity and central atrium (with and without extraction fan) for Edinburgh model.....	184
Figure 6.1: Summary of case study method.....	191
Figure 6.2: Simulation overall energy consumption result.....	195

Figure 6.3: Impact of window films on heating energy consumption	197
Figure 6.4: Impact of window films on cooling energy consumption	199
Figure 6.5: Impact of window films on the cooling load profile for a typical hot sunny summer day.....	201
Figure 6.6: Impact of window films on the heating load profile for a typical cold mostly clear winter day.....	203
Figure 6.7: Impact of window films on the radiant temperature on a typical hot sunny summer day	204
Figure 6.8: Impact of window films on overall lighting energy consumption	205
Figure 6.9: Impact of window films on CO ₂ emissions.....	207
Figure 6.10: Impact of window films on natural gas cost.....	209
Figure 6.11: Impact of window films on electricity cost	211
Figure 6.12: Impact of window films on overall energy cost	213
Figure 6.13: Typical floor plan showing zone allocation and building orientation.....	217
Figure 6.14: Impact of window films applied to the east or west facing windows on the overall energy consumption.	218
Figure 6.15: Simulation overall energy consumption results (Hilton London Heathrow)	220
Figure 6.16: Impact of window films on heating energy consumption (Hilton London Heathrow)	222
Figure 6.17: Impact of window films on cooling energy consumption (Hilton London Heathrow)	224
Figure 6.18: Impact of window films on CO ₂ emissions (Hilton London Heathrow)	227
Figure 6.19: Impact of window films on overall energy cost	229
Figure 6.20: Simulation overall energy consumption results (Hilton Reading, Edinburgh simulation)	232

Figure 6.21: Impact of window films on heating energy consumption (Hilton Reading, Edinburgh simulation)	234
Figure 6.22: Impact of window films on cooling energy consumption (Hilton Reading, Edinburgh simulation)	236
Figure 6.23: Impact of window films on CO ₂ emissions (Hilton Reading, Edinburgh simulation)	238
Figure 7.1 Typical energy savings of a CHP system relative to traditional energy sources of heat and power generation in the UK (Carbon Trust, 2010).	247
Figure 7.2: Summary of case study method.....	251
Figure 7.3: showing the breakdown of building energy demand.....	253
Figure 7.4: Total energy consumption result (without CHP vs. with CHP)	254
Figure 7.5: Electricity generation results and total energy consumption.....	256
Figure 7.6: Cost and carbon emission result (without CHP vs. with CHP).....	258
Figure 7.7: Total energy consumption result (without CHP vs. with 307kWe CHP)	260
Figure 7.8: Electricity generation results and total energy consumption (307kWe CHP).....	262
Figure 7.9: Cost and carbon emission result (without CHP vs. with 307kWe CHP)	264
Figure 7.10: Impact of UK Grid decarbonisation on the carbon emissions for the CHP installation	267
Figure 7.11: Showing the relationship between key energy performance parameters and variation in CHP sizes.....	269

List of Tables

Table 2.1 Summary table of previous studies on performance gap and estimation of building energy performance	35
Table 2.2: Summary table of previous studies on the impact of window glazing and glazing energy improvement measures	45
Table 2.3: Summary table of previous studies on the impact of glazed building façade on building energy performance	50
Table 2.4: Types of CHP and application.....	54
Table 2.5: CHP financing options.....	59
Table 2.6: UK Grid emissions intensity data set.....	67
Table 2.7: Summary table of previous studies on performance and application of CHP Systems in efficient energy production.....	73
Table 3.1: General description of input used in the models	81
Table 4.1: General description of input used in each model.....	112
Table 4.2: Modelling and simulation parameters based on the case study building’s characteristics (Hilton Reading hotel)	115
Table 4.3: Modelling and simulation assumptions based on NCM building type and use for Hilton Reading Hotel	116
Table 4.4: Summary of building services input (Hilton Reading hotel).....	117
Table 4.5: Modelling and simulation parameters based on the case study building’s characteristics (Hilton London Heathrow Airport Terminal 4)	118
Table 4.6: Modelling and simulation assumptions based on NCM building type and use for Hilton London Heathrow Airport Terminal 4.....	119
Table 4.7: Summary of building services input (Hilton London Heathrow Airport Terminal 4)	120

Table 4.8: Modelling and simulation parameters based on the case study building’s characteristics (Hilton London Gatwick Airport).....	121
Table 4.9: Modelling and simulation assumptions based on NCM building type and use for Hilton London Gatwick Airport)	122
Table 4.10: Summary of building services input (Hilton London Gatwick Airport)	123
Table 6.1: Performance Properties of PR 70 EXT applied to a typical single and double pane clear or tinted window (3M, 2016).....	192
Table 6.2: Performance Properties of PR 40 EXT applied to a typical single and double pane clear or tinted window (3M, 2016).....	193
Table 6.3: Summary table showing percentage difference between simulation result without window film compared to simulation result incorporating window films on all orientation	215
Table 6.4: Summary table showing percentage difference between simulation result without window film compared to simulation result incorporating window films on all orientation (Hilton London Heathrow).....	230
Table 6.5: Summary table showing percentage difference between simulation result without window film compared to simulation result incorporating window films on all orientation (Hilton Reading, Edinburgh simulation).....	240
Table 7.1: UK electricity emissions factor projections.....	266
Table 7.2: Summary table showing percentage difference between key simulation results without CHP compared to simulation results incorporating CHP	269

List of Acronyms/Abbreviations

ADE	Association of Decentralised Energy
AHU	Air Handling Units
ASHRAE	American Society of Heating, Refrigerating and Air Conditioning Engineers
BEEM	Building Energy and Environmental Modelling
BEIS	Department for Business, Energy and Industrial Strategy
BLAST	Building Loads Analysis and System Thermodynamics
BRE	Building Research Establishment
BREEAM	Building Research Establishment Environmental Assessment Method
BRUKL	Building Regulations United Kingdom Part L
BS	British Standard
CAD	Computed Aided Design
CCGTs	Combined Cycle Gas Turbines
CCL	Climate Change Levy
CEN	European Committee for Standardization
CIBSE	Chartered Institution of Building Services Engineer
CFD	Computational Fluid Dynamics
CH ₄	Methane

CCHP	Combined Cooling and heating and Power
CHP	Combined Heat and Power
CHPQA	Combined Heat and Power Quality Assurance Programme
CO ₂	Carbon-dioxide
CO ₂ -eq	Carbon-dioxide equivalent
COP	Conference of Parties
CRC	Carbon Reduction Commitment
DCLG	Department of Community and Local Government
DECC	Department of Energy and Climate Change
DOE-2	Department of Energy
DHW	Domestic Hot Water
DSF	Double Skin Façade
DSM	Dynamic Simulation Model
DSY	Design Summer Years
ECA	Enhanced Capital Allowances
ECM	Energy Conservation Measures
EDSL	Environmental Design Solution LTD
EEP	Energy and Emissions Projections

EN ISO	International Organisation for Standardisation, European Norm
EPA	United States Environmental Protection Agency
EPBD	Energy Performance of Building Directive
EPC	Energy Performance Certificate
ERMs	Energy Retrofit Measures
ESCO	Energy Service Company
ESP-r	Integrated energy modelling tool
ETTV	Envelope Thermal Transfer Value
EU	European Union
EUI	Energy Use Intensity
FCU	Fan Coil Units
gCO _{2e}	Grams Carbon-dioxide equivalent
GHG	Green House Gas
G-Value	coefficient of solar energy transmittance of glass
HDD	Heating Degree Days
HVAC	Heating Ventilation and Air Conditioning
IEA	International Energy Agency
IPCC	Intergovernmental Panel on Climate Change

ISO	International Organisation for Standardisation
K	Unit of measurement of temperature, Kelvin
Kg	Kilo-grams
kWh/m ²	Kilowatt hours per square metre
kWe	Kilowatt electricity
LCICG	Low Carbon Innovation Coordination Group
LED	Light-emitting Diode
LEED	Leadership in Energy and Environmental Design
LSG	Light to Solar Gain
MtCO ₂	Metric Tons of Carbon-dioxide
MW	Mega-Watt
MWe	Mega-Watt electricity
MWh	Mega-Watt-Hour
NCM	National Calculation Methodology
NEEAPs	National Energy Efficiency Action Plans
NO _x	Nitrogen Oxide
OECD	Organization for Economic Cooperation and Development
OFGEM	Office of Gas and Electricity Market

ORC	Organic Rankine Cycles
Pa	Pascal
PDSYs	Probabilistic Design Summer Years
PFI	Private Finance Initiative
POE	Post Occupancy Evaluation
ppm	parts per million
PV-CHP	Photovoltaic Combined Heat and Power
RCEP	Royal Commission on Environmental Pollution
SAP	Standard Assessment Procedure
SBEM	Simplified Building Energy Model
SC	Shading Coefficient
SHGC	Solar Heat Gain Coefficient
T	Temperature
TAS	Thermal Analysis Software
TBD	TAS Building Designer
Tc	Thermal comfort
TM	Technical Memorandum
TRY	Test Reference Year

TWh	Terawatt-hour
UHI	Urban Heat Island
UK	United Kingdom
UKCP	United Kingdom Climate Projections
UNEP-SBCI	United Nations Environmental Protection - Sustainable Building and Climate Initiative
UNFCCC	United Nations Framework Convention on Climate Change
US	United States
USGBC	United States Green Building Council
UTC	Universal Time Coordinated
UV	Ultraviolet
U-Value	Thermal transmittance
VAV	Variable Air Volume
VB	Venetian Blinds
WCDH	Weighted Cooling Degree Hours
WMO	World Metrological Organisation
WWR	Wall-to-Window Ratio

In The Name of Allah - The Most Beneficent - The Merciful

Dedicated To

My beloved parents,

Surv. Ibrahim Mohammed Rotimi

&

Hajia Ajoke Rotimi

Who have dedicated their lives for me and my wellbeing with boundless
love and support

Acknowledgements

I am grateful to all those with whom I have had the pleasure to work with throughout the course of my research. I am thankful to the entire supervisory team: Dr. Anastasia Mylona, Dr. Paulina Godfrey, and Mr. Darren Cook for their guidance and valuable insight throughout my doctoral studies. I am particularly grateful and indebted to my principal supervisor, Dr. Ali Bahadori-Jahromi for his guidance, extensive personal, technical and professional support and who has taught me in-depth knowledge about research and life in general. I am also very thankful to him for providing me with the opportunity to gain teaching experience and training.

The support of my family members has been highly important to me in the pursuit of my doctorate degree. I would like to express my gratitude to my parents and siblings (Amina and Mohammed-awal) for their endless prayers and support. I am also grateful to all my friends, particularly Abubakar Sani Kawuwa and Oluwatoyin Ajibade, for their encouragement and counsel. A very special mention to my fiancée, Amina Abdulsalam for her unfaltering emotional support, kind wishes and prayers.

Above all, I would like to thank the almighty Allah, for life, good health, His infinite mercies and all things.

List of Published and Submitted Journal Papers

Parts of the work presented in this thesis have appeared in the following publications that have been produced in advance of this thesis:

1. Rotimi, A., Bahadori-Jahromi, A., Mylona, A., Godfrey, P. and Cook, D. (2017). 'Estimation and Validation of Energy Consumption in UK Existing Hotel Building Using Dynamic Simulation Software', *Sustainability*. Multidisciplinary Digital Publishing Institute 9 (8) p. 1391. <https://doi.org/10.3390/su9081391>
2. Bahadori-Jahromi, A., Rotimi, A., Mylona, A., Godfrey, P. and Cook, D. (2017) 'Impact of Window Films on the Overall Energy Consumption of Existing UK Hotel Buildings', *Sustainability*. Multidisciplinary Digital Publishing Institute, 9(5), p. 731. <https://doi.org/10.3390/su9050731>
3. Rotimi, A., Bahadori-Jahromi, A., Mylona, A., Godfrey, P. and Cook, D. (2017) 'Impact of cavity extraction fans on thermal and energy performance of existing UK hotel'. *Proceedings of the Institution of Civil Engineers – Engineering Sustainability*, <https://doi.org/10.1680/jensu.17.00017>
4. Rotimi, A., Bahadori-Jahromi, A., Mylona, A., Godfrey, P. and Cook, D. (2018) 'Optimum size selection of CHP retrofitting in existing UK hotel building', *Sustainability- Multidisciplinary Digital Publishing Institute*, 10(6) p. 2044. <https://doi.org/10.3390/su10062044>

Chapter 1: General Introduction

1.1 Background

The complex and wide-ranging effects of climate change can include a rise in sea levels, flooding, drought and increased temperature (WMO, 2013). The certainty of the adverse impact of climate change and the possibility that the increasing cause of global warming pollutants (greenhouse gases) is human activities is now widely acknowledged (Taylor *et al.*, 2010; UKCP, 2010; Amoako-Attah, 2015). A substantial reduction in the amount of carbon dioxide (CO₂) emissions resulting from human activities is required to curb global warming, which has led to the development of numerous measures to ensure that cleaner and more efficient energy sources are utilised in all facets of people's lives. The historic legally binding universal agreement to curb climate change that was recently reached in the United Nations Framework Convention on Climate Change (UNFCCC) Conference of Parties (COP) 21 further shows the increased global commitment to limit anthropogenic climate change (UNFCCC, 2015). The agreement aims to ensure the global temperature rise in this century is significantly below 2 degrees Celsius and to limit the temperature increase even further to 1.5 degrees Celsius above pre-industrial levels (UNFCCC, 2015).

The United Kingdom (UK) is amongst the leading countries taking significant measures to generally improve energy efficiency. This helps the UK accomplish two main strategic aims in its energy policy of reducing CO₂ emissions to agreed standards and to ensure the sustainable provision of affordable energy to meet increasing demand (Amoako-Attah, 2015). Therefore, a law was put in place to ensure a 60% reduction in CO₂ emissions by 2050, following the Royal Commission on Environmental Pollution's (RCEP) report in 2000 (RCEP, 2000). This target has since increased to 80% (Climate Change Act, 2008). Justifiably, considerable focus is put on

reducing the CO₂ emissions from buildings (residential and commercial) since studies/analysis have shown that they account for a substantial proportion of the country's emissions (Carbon Trust, 2013). The UK building stock is one of the oldest in Europe, with over a third of dwellings constructed before 1945 and one quarter of the of non-domestic building stock constructed before 1940 (National Energy Efficiency Action Plans (NEEAPs), 2017). Therefore, to achieve the CO₂ emissions reduction, it is important to significantly reduce emissions from existing buildings which makes up the bulk of buildings.

Among existing buildings, a considerable number of studies have been conducted on improving the thermal performance and efficiency of dwellings primarily because they account for most of the existing buildings and consume more energy than the commercial and public administration (Department of Energy & Climate Change, 2015). However, to attain the UK's overall goal of reducing CO₂ emissions by 80%, it is equally imperative that the thermal performance and efficiency of non-domestic buildings be effectively studied (BRE, 2000). Possible explanations for the high emissions in hotels can be attributed to the fact that hotels generally prioritise comfort of guests and the guest mind-set is centred on experiencing luxury without the added pressure of behaving in an energy efficient manner that they might encounter elsewhere (Roberts, 2008). Moreover, hotels operate on a 24/7, 365 days a year basis. This unique occupancy behaviour makes reducing emissions a further challenge. The Carbon Trust (2013) highlighted that although emissions from dwellings are more than that of the commercial buildings, emissions from commercial buildings, offices, factories, hotels, hospitals and schools account for 18% of the UK's CO₂ emissions with an annual energy consumption of 300TWh (Carbon Trust, 2013). This consumption value is equivalent to Switzerland's principal energy supply (Carbon Trust, 2013).

Additionally, energy efficiency measures are more cost effective in commercial buildings because they are typically larger than dwellings.

It is important to make informed strategic decisions and investments in relation to energy performance improvements which incorporate cost effective and sustainable environmental considerations. These decisions and solutions should be knowledge based and sustainable. An important initiative that started against the backdrop of the historic Paris Conference of Parties (COP) 21 Agreement by over 100 leading corporates is the ‘science-based targets’ (Carbon Trust, 2016a). According to the Carbon Trust (2016a), a science-based target is defined as a carbon emission reduction target that is in line with the measure of reductions needed to achieve the global temperature increase below 2°C compared to pre-industrial temperatures as described in the assessment reports of the Intergovernmental Panel on Climate Change (IPCC). The initiative entails making revolutionary commitments to set carbon emissions targets that are underpinned with the best available science; over 170 companies have made commitments, with approximately 2 major businesses per week signing up (Carbon Trust, 2016b). This new corporate commitment shown by leading companies will only encourage other companies in all sectors, including the hospitality industry, to align their decarbonisation and energy efficiency strategies with the science-based target. Some of the measures that can be employed to achieve reduced CO₂ emissions, particularly in commercial buildings, include implementing energy efficiency and management, retro-fitting new technologies (relating to both the building fabric, lighting, Heating Ventilation and Air Conditioning (HVAC) and the activities within) and exploring onsite building-integrated thermal and electrical generation such as, Combined Heat and Power (CHP) and solar hot water generation (Jenkins *et al.*, 2009).

To evaluate the effectiveness of the various options, computer aided dynamic simulation software packages are normally used. Collins (2012), argues that the need to estimate annual energy consumption in existing buildings and the built environment at large is becoming ever more important, as greater attention is now being placed on effectively controlling utility costs, total energy consumption and CO₂ emissions. Estimated energy use can be utilised for various purposes such as justification for proposed refurbishment works, developing budgets for utility costs, demonstrating compliance with certain regulation targets etc. The European Union (EU) ‘Energy Performance of Building Directive’ (EPBD), which is aimed at helping its member states attain higher energy efficient buildings, places emphasis on the necessity to develop certain methodologies for energy performance estimation and the issuance of an energy performance certificate (Gucyeter & Gunaydin, 2012). The directive specifically makes it compulsory for all member states to develop national calculation methodologies that are in conformity with the structure of the directive’s findings (EPBD, 2002). In the UK, two main systems are used for domestic and non-domestic buildings to demonstrate compliance with the EPBD directive. The Standard Assessment Procedure (SAP) for the energy rating of a dwelling is used for domestic buildings whereas the Simplified Building Energy Model (SBEM) which accommodates a broader variety of building types is used for non-domestic buildings (BRE, 2006). “Part L: Conservation of Fuel and Power” of the Building Regulations governs the energy efficiency of new buildings (of all types) in England and Wales with extensions such as L2A for new non-domestic buildings and L2B for work in existing non-domestic buildings (BRE, 2006). Although there has been significant progress made in the area of tools (software packages) designed to estimate the energy performance of buildings, they still have some limitations in their capability to accurately predict

the energy performance of an actual building with real occupancy behaviour and activities (Menezes *et al.*, 2012).

Therefore, from the issues highlighted above and a review of the relevant body of knowledge, this research aims to address the impact of the use of various energy improvement technologies or measures on the thermal performance and energy efficiency of UK hotel buildings with the aid of a computational dynamic simulation software (with application to Hilton hotels). The energy improvement measures that are considered are the efficient technologies which are been marketed by numerous suppliers; the impact of these technologies on the overall building energy performance is examined when installed individually and in different combinations. A review of past research indicates that studies investigating the effect of interventions and technologies on the thermal performance and efficiency of hotels in the UK have mostly been done on the design of new buildings. Moreover, when these technologies are examined in existing buildings, the interdependency and knock-on effects that they have on the overall energy performance of the building are not analysed. This research aims to contribute to this gap in knowledge by analysing the interdependency and impact that these various technologies have on buildings, thereby helping building professionals and hotel management in making relatively quick and informed decisions in the application of various energy improvement interventions/technologies towards improving the thermal performance and energy efficiency of hotels.

1.2 Aim

The main focus of this research is to evaluate the impact of various technologies on the thermal performance and energy efficiency of hotel buildings using holistic whole building simulation models. The holistic models are developed with thermal analysis simulation software to enable testing of the impact of various energy improvement technologies and measures on the thermal

performance and efficiency of hotel buildings. The simulations give results in formats that allow for the drilling down of individual systems or plant items and also enable the study of the effect of improvements/interventions made to buildings, that is, considering the adverse or knock-on effects that these improvements might have on each other. For example, the introduction of LED lamps meant to reduce the lighting energy consumption can have an impact on the overall cooling load (i.e. by reducing the amount of heat emitted as compared to conventional halogen lights), consequently increasing the heating requirement and how this affects the efficacy of solar film installation in windows or an existing shading system.

1.3 Identified knowledge gap

This research makes a scholarly contribution with an approach employing the practical application of whole building thermal analysis simulation software to examine the energy and thermal performance of existing buildings. In particular, this whole building simulation approach considers the knock-on effects of the different installed energy improvement measures on the energy performance of buildings. This work also identifies from the literature some areas requiring further research.

1. Reduction of the performance gap between estimated building energy consumption using dynamic simulation models and the actual site consumption, especially in hotel buildings.
2. Impact of building façades, particularly the double-skin façade (DSF) and its cavity space ventilation, on the thermal performance and the overall energy performance of existing hotel buildings.
3. Impact of glazing and glazing energy improvement retrofit on the energy performance of existing commercial buildings, especially hotels.

4. Impact of Combined Heat and Power (CHP) systems on the energy performance of existing UK hotel buildings and optimum size selection in CHP retrofitting.

1.4 Objectives

The objectives presented below are employed to achieve the aim of this research:

1. Estimation and validation of energy consumption in existing UK hotel building using dynamic simulation software.

Tasks to achieve aim:

- a. Collection of all necessary data such as CAD plans, building fabric makeup, plants/system information and operating energy consumption and site survey to verify the collected data.
- b. Creation of a hotel model on the dynamic simulation software using the collected data
- c. Estimation of annual energy consumption of the hotel using the Building Regulation Part L model.
- d. Estimation of annual energy consumption of the hotel using a bespoke energy model. This is done through the systems modelling component of the dynamic simulation software.
- e. Improvement of the system modelling result by estimating and accounting for (unregulated energy use) catering energy use.
- f. Validation of the model's results and comparison against actual building operational energy consumption.

2. **Evaluation of the** impact of extraction fans in the cavity of the east and west double-skin facade on the overall energy consumption and thermal performance of existing UK hotel buildings.

Tasks to achieve aim:

- a. Collection of all necessary data such as architectural plans, building fabric makeup, plants/system information and operating energy consumption. A site survey was also undertaken to verify the collected data.
 - b. Development of the hotel model in the dynamic simulation software using the data obtained.
 - c. Estimation of the annual overall energy consumption of the hotel via the system modelling component of the dynamic simulation software.
 - d. Improvement of the system modelling result by including estimation of unregulated energy use (catering energy use); subsequently, validation of the model's results and comparison against actual building operational energy consumption.
 - e. Incorporation of extraction fans in the DSF cavity of the hotel building model and comparison of the energy and thermal performance to the hotel model without the extraction fans.
3. **Evaluation of the** impact of window films on the overall energy consumption of existing UK hotel buildings.

Tasks to achieve aim:

- a. Collection of all necessary data such as architectural plans, building fabric makeup, plants/system information and operating energy consumption. A site survey and visitation were also undertaken to verify collected data.
 - b. Development of a hotel model on the dynamic simulation software using the data obtained.
 - c. Estimation of the annual overall energy consumption of the hotel via the system modelling component of the dynamic simulation software.
 - d. Improvement of the system modelling result by including estimation of unregulated energy use (catering energy use); subsequently, validation of the model's results and comparison against actual building operational energy consumption.
 - e. Incorporation of window films into the hotel building model and comparison of the energy performance to the hotel model without the window films.
4. **Evaluation of the** impact of CHP systems on the energy performance of existing UK hotel buildings and optimum size selection in CHP retrofitting.

Tasks to achieve aim:

- a. Collection of all required data including architectural plans, building fabric properties, plants/system information, building occupancy information and operating energy consumption; a site survey and visitation were also undertaken to verify the collected data.
- b. Creation of a hotel model on the dynamic simulation software using the collected data.
- c. Estimation of the annual total energy consumption of the hotel through plant/system modelling on the dynamic simulation software; subsequently,

verification of the model's results via comparison of the model result against actual building operational energy consumption.

- d. Incorporation of the CHP into the hotel building model to evaluate the possible maximum CHP size based on the hotel's base heating load with the priority to meet Domestic Hot Water (DHW) demand, which is substantial and consistent throughout the year; hence, ensuring that all the heat produced by the CHP is utilised.
- e. Reduction of the estimated maximum size by 10%, 20%, 30%, 40%, 50%, 60% and 70%. Subsequently, critical analysis of the CHP performance over this range is employed as a basis of selection of the optimum CHP size.

1.5 Motivation and research questions

The main motivating factors that are driving this research are the potential it has towards contributing to existing knowledge and contribution to business. The need to reduce carbon emissions due to the adverse impact of global warming has prompted responses especially in the UK building regulation, which favours building fabrics and technologies that increase the airtightness of buildings. This has increased the risk of overheating in buildings especially in regard to increasing warmer future weather predictions, which means more energy might be expended in the future for cooling especially in hotels which prioritise customer satisfaction. This research will therefore contribute to ongoing research trends that focus on providing sustainable solutions to this intricate balancing challenge in providing efficient buildings. The contribution to business for this research is from its potential to highlight possible energy improvement measures to hotel decision makers and provide them with an idea of where they can invest their money and prioritisation of investment.

Additionally, the potential of this research to answer the research questions is another motivating factor. These research questions are:

- What methodology can be adopted to use thermal analysis software as a simple and practical approach in the estimation and validation of energy consumption in existing UK hotel buildings?
- What are the effects of various improvement interventions and technologies on the efficiency of hotels in the present climatic conditions?
- Which of the various technologies are the most appropriate in improving the efficiency of hotels based on their interdependency with each other?
- Which of the considered technologies/interventions are the most appropriate for new buildings and which are best suited as retrofits for existing buildings?

1.6 Thesis outline and chapter layout

Chapter 1: General introduction

The introduction chapter presents a general background of the study area highlighting the relevance of the research topic to the United Kingdom's commitment to reducing energy consumption in buildings. It also lays out the research aim and objectives and identifies the knowledge gap, the motivation behind the research and the research questions.

Chapter 2: Literature review

The literature review chapter presents a critical evaluation of key issues underpinning the aim and objectives of this research. These include the existing body of knowledge on energy efficiency, building carbon emissions reduction, building modelling and simulation, building energy improvement measures, building façades and glazing and Combined Heat and Power (CHP).

Chapter 3: Methodology

This chapter lays out the research method employed for the study. It highlights the research philosophy, research design, ethical concerns and the general modelling and simulation process used in the study.

Chapter 4: Estimation and validation of energy consumption in existing hotel buildings in the UK using dynamic simulation software

This chapter presents an approach of estimating and validating the energy consumption of an existing hotel building. The approach helps to reduce the expected performance gap between the operational energy estimate and actual building energy use.

Chapter 5: Impact of extraction fans in the cavity of the east and west double-skin façade (DSF) on the overall energy consumption of an existing UK hotel building

This chapter presents a case study exploring the impact of installed extraction fans in the DSF cavity of an existing hotel building on the thermal and energy performance of the building. It considers the prevailing thermal condition of the DSF cavity space and consequently, examines its influence on the thermal behaviour of the adjoining large central atrium and its impact on the total energy performance of the building.

Chapter 6: Impact of window films on the overall energy consumption of existing UK hotel buildings

This chapter investigates the holistic energy performance improvement potentials of solar window film retrofitting in existing UK hotel buildings via thermal simulation of two different types of

case study hotel buildings. It interrogates the holistic models to evaluate the impact of the solar window films on the various components of the buildings' energy consumption.

Chapter 7: Optimum size selection of Combined Heat and Power (CHP) retrofitting in existing UK hotel buildings

This chapter evaluates the impact of CHP systems on the energy performance of existing UK hotel buildings with the aid of whole building simulation software, including an approach of optimum size selection in CHP retrofitting.

Chapter 8: Conclusions and Recommendations

This final chapter presents the main conclusions deduced from the previous chapters including a summary of the conclusions of the studies undertaken in the thesis. This chapter also highlights the practical application of the outcome of the thesis, the study limitations, its modest contributions to knowledge and recommendations of logical areas of continuation for future studies.

Chapter 2: Literature Review

2.1 CO₂ Emission Reduction and Energy Consumption

Considerable scientific proof of the manifestation of climate change, its man-made origin and possible overwhelming impacts continue to accrue (IEA, 2013a). King *et al.* (2015) highlighted that owing to the increased man-made emissions of greenhouse gases (GHG), there have been higher global temperature and sea level rises in recent times compared to the preceding decade. Consequently, in order to mitigate the severe environmental costs for billions of people, it is imperative to keep the global rise in temperature, which is already 0.8°C, above the pre-industrial level to 2 °C below this level (King *et al.*, 2015). The environmental consequences include more extreme drought, gales, heat waves and flooding that can result in loss of livelihood for millions, increased global migration, tensions and the risk of war.

The adverse impact of GHG emissions has global consequences and thus, tackling climate change involves coordinated action by nations around the world. Therefore, the UNFCCC was established in 1992 as the foremost body for international action on climate change. This international convention has been subscribed to by 195 countries and negotiations are focused on four major areas (Committee on Climate Change, 2017):

- Abating greenhouse gas emissions
- Adapting to climate change
- Reporting of national emissions
- Financing of climate action in developing countries

According to the UNFCCC (2014), Article 2 of the UNFCCC 1992 convention states that the main aim of the convention is to accomplish the stabilization of GHG concentrations in the atmosphere at a level that would mitigate harmful anthropogenic interference with the global climate. This level should be attained in a timely manner to enable natural adaptation of ecosystems to climate change, to guarantee that food production is not endangered and to allow economic development to proceed in a sustainable fashion. However, the recent CO₂ concentration in the atmosphere has increased to 400 ppm (parts per million) from 270 ppm in the pre-industrial period and continues to increase in excess of 2 ppm annually (United States Environmental Protection Agency, 2016). This current relentless increase in the levels of atmospheric CO₂ further highlights the seriousness of the situation. According to the IEA (2013a) in order to help guard against the adverse impacts of climate change, the global international consensus is that maintaining the concentration of GHG at below 450 ppm of CO₂ equivalent is in agreement with a near 50% chance of achieving the 2°C target below the pre-industrial level. Moreover, some experts argue that the perils earlier thought to be correlated with a global temperature increase of about 4°C are presently associated with an increment of just over 2°C. Similarly, the dangers formerly linked with 2°C are now believed to arise with just a 1°C temperature increase (Smith *et al.*, 2009).

To improve the chances of adequately curbing the impact of climate change, it is imperative that the GHG emissions, especially CO₂ from global energy consumption, is significantly reduced, as it is the primary source of GHG emissions. Energy is central to all economic and social development and an enhanced quality of life. Energy is defined as the ability to do work and it is available in different forms, for example, mechanical, electricity, thermal, chemical, nuclear, radiant, gravitational and sound (Bilgen, 2014). The main sources of energy can be fossil fuels (such as coal, natural gas, shale oil, petroleum, etc.); renewables (such as hydro, biomass, wind,

solar, geothermal) and fissile material derived from atoms like uranium, plutonium, etc (Bilgen, 2014).

According to the IEA World Energy Outlook (IEA, 2016), the energy sector was responsible for over two-thirds of the overall global GHG emissions in 2010 with around 90% of this energy associated GHG emissions being from CO₂ and about 9% from methane (CH₄) and its effect is normally analysed in terms of carbon-dioxide equivalent (CO₂-eq). Nonetheless, the global energy consumption remains on the increase, mainly driven by fossil fuels, which account for more than 80% of global energy consumption, a proportion of which has steadily been on the increase since the mid-1990s (IEA, 2013a).

Additionally, the fast growth witnessed in the use of coal in recent times has basically abated primarily due to increased environmental concerns (IEA, 2016). Therefore, there was a 0.1% marginal but encouraging reduction in CO₂ emissions from combustion of fossil fuel, cement production and other processes globally in 2015 (Olivier *et al.*, 2016). However, this reduction in global emissions, which can be better described as a stall in CO₂ emissions, was not accidental, especially if the uncertainty in the trend from the data sources are taken into account. Rather, the reduction was due to structural changes in the global economy, the improvement in global energy efficiency and in the energy mix of major world players (Olivier *et al.*, 2016). Furthermore, for the first time in at least four decades, the stalling or reduction in emissions is not wholly or partly associated with an economic downturn (IEA, 2015). Especially since emissions across the Organization for Economic Cooperation and Development (OECD) continued to dissociate from economic growth, similarly, emission records from China indicated initial signs of a diminishing correlation between economic expansion and emission growth, even though it is not yet completely detached (IEA, 2015). A joint report by the Netherlands Environmental Agency and the European

Commission on the trend in global CO₂ emissions (Olivier *et al.*, 2016) provided the key data behind the stall in global CO₂ emissions observed in 2015 as follows:

- Two major global players, China and the United States, decreased their CO₂ emissions by 0.7% and 2.6% respectively compared to 2014. One key factor responsible for the Chinese reduction in CO₂ emissions was the change in their energy mix and the economy. The energy mix in China witnessed a 1.5% reduction in coal and 1% increase in the proportion of renewable fuel in primary energy consumption. The increase in non-fossil fuels was attained due to growth in nuclear energy by 29%, hydropower by 5% and others such as wind and solar energy by 21%. Similarly, the United States significantly reduced their CO₂ majorly due to a 13% reduction in coal consumption, which is the largest comparative reduction in any fossil fuel consumption in over half a century, with most of the electricity produced by gas fired plants.
- There was also a 3.4% and 2.2% reduction in emissions by the Russian Federation and Japan respectively, although this was negated by 5.1% and 1.3% increases in emissions by India and the European Union respectively. Moreover, there were increased emissions from a substantial group of the smallest countries. The 1.3% increase in the European Union's CO₂ emissions was preceded by four years of reductions in annual emissions on a 3.1% average rate. This stagnation and subsequent increase was largely caused by a 4.6% increase in the consumption of natural gas for space heating and generation of electricity and a 4% increase in diesel consumption in the transport sector. Conversely, there was a 1.3% in electricity generation in 2015 with a less than 1% associated emissions reduction

mainly due to a considerable 29% larger share of non-fossil fuel electricity from wind, solar and hydropower. The increased share of renewable electricity resulted in a 1.8% reduction in coal consumption, which was mainly used in the power generation sector.

The slowdown in energy-linked CO₂ emissions, as highlighted above, was primarily due to a 1.8% improvement in the energy intensity of the global economy, a shift strengthened by the improvement in energy efficiency along with the global expansion in the use of cleaner and mostly renewable energy sources (IEA, 2016). Therefore, it is important that further global efforts aimed at improving energy sector efficiency are needed, as the current trend demonstrates the potential of low-carbon energy consequently giving credibility to meaningful action on global climate change. This is particularly the case as it is widely acknowledged that transformative change in the energy sector, which accounts for at least two-thirds of global GHG emissions, is crucial to attain the goals of the COP21 Paris Agreement on climate change (IEA, 2016).

Most countries that are party to the Paris Agreement are on track to attain, and in some cases, surpass several of the targets set in their Paris Agreement commitments. Although this is adequate to slow the predicted rise in global energy-linked emissions, it is not sufficient to limit the global warming to less than 2 °C (IEA, 2016; Committee on Climate Change, 2017). Moreover, the new US Administration has declared that it will quit the Agreement. However, several other countries, organisations, and subnational governments have reaffirmed their commitment in response to this announcement (Committee on Climate Change, 2017). These countries include major stakeholders such as China, India, the EU, Canada, Mexico and Australia; also, within the US, there is the US Climate Alliance of states (accounting for around a fifth of US emissions and two-fifths of US Gross Domestic Product) and the US Climate Mayors (comprising over 200 cities). Hence these

commitments and advancement in establishing global national-level policies denote that the global shift towards a low-carbon economy is well in motion (Committee on Climate Change, 2017).

2.2 Energy Efficiency and CO₂ Emission Reduction in Buildings

The effect of greenhouse gases like CO₂ from human activities resulting in global warming and climate change is generally recognised and proof of its impacts on buildings needs little justification (UKCP, 2010; Amoako-Attah, 2015). It is also widely acknowledged that average temperatures will probably continue to increase, indicating that peak summer temperatures in the UK will increase by up to 7 degrees Celsius over the coming century (CIBSE, 2005; Kendrick *et al.*, 2012). CIBSE (2005), This expected temperature increase will have considerable effects on the indoor thermal condition of UK buildings, with major concerns such as overheating, the implementation of various passive cooling and comfort cooling strategies and the possible impact of these strategies on energy use.

Any approach implemented to achieve a comfortable internal building environment in the light of increasing temperatures must be energy efficient as presently, research works on the sources of emissions show that buildings account for bulk of the emissions. In the UK, studies have revealed that the direct CO₂ emissions from buildings account for at least 19% of the UK GHG emissions (Committee on Climate Change, 2017). Moreover, the UK emissions decreased by 6% in 2016, although this improvement was unbalanced as the reduction was almost solely attributed to power generation, where there was a swift fall in coal power generation and a resultant 24% reduction in emissions (Committee on Climate Change, 2017).

According to Ürge-Vorsatz *et al.*, (2015), buildings and their associated activities represent a sizeable share of global environmental challenges. These environmental concerns, mainly

influenced by the amount and quality of the energy consumption in the building, are internal and external air pollution, associated health hazards, energy dependence and security. Moreover, building energy consumption also poses significant energy-linked challenges to sustainable development, which includes mortality linked to indoor cooking, insufficient energy resources to facilitate economic growth and development, inequality in the accessibility to modern energy services and global climate change (Ürge-Vorsatz *et al.*, 2015). Many developed and developing countries have established regulations aimed at the reduction of building energy consumption by significantly improving the energy efficiency of buildings (Sorgato *et al.*, 2016). Therefore, it is clear that an adequate focus is needed to mitigate against emissions from buildings. This can be achieved by considerably improving the energy efficiency of buildings thus reducing energy consumption and CO₂ emissions.

CIBSE (2012) describes an energy efficient building as a building that consumes the minimum amount of energy to provide the required internal environment and services in a cost efficient and environmentally viable way; that is, energy efficiency does not compromise on comfort. Energy efficiency is important in both new and existing buildings as new buildings designed for low-carbon systems can forestall expensive future retrofit and reduce energy utility cost (Committee on Climate Change, 2017). Furthermore, improvement in the energy efficiency of the existing building stock can reduce emissions and energy utility costs, enhance competitiveness and asset values for business, improve the internal building environment, help to reduce fuel poverty and improve the suitability of the building for the incorporation of low-carbon heating in the future (Committee on Climate Change, 2017).

Primarily in UK buildings, about half of the energy demand is utilised for space heating, especially in the service sector (offices, retail, education hotels and catering), with health and hotels having

the highest consumption of energy by unit floor because of longer periods of occupancy and high hot water demand (BRE, 2000). The possible positive impact of an already warming and even warmer predicted future climate on energy consumption is the reduction in heating energy use. A report by the Intergovernmental Panel on Climate Change (IPCC) advocates that an 18% reduction in CO₂ emissions (14.5 MtCO₂) is attainable for commercial and public-sector buildings by implementation of no/low cost energy efficiency strategies (IPCC, 2007). In addition, the potential for a further reduction of 23% (18 MtCO₂) is possible through the incorporation of micro-generation technologies. The Low Carbon Innovation Coordination Group LCICG report (2012) suggests that there is substantial potential for energy savings across the UK's existing, new and refurbished buildings. LCICG (2012), highlighted that energy savings of up to 18 MtCO₂ by 2020 are achievable by application of innovative energy saving measures in non-domestic buildings and a further 86 MtCO₂ by 2050, depending on the implementation rate of the energy saving measures. The potential cost savings from these abatement measures can be up to £13 billion by 2050.

The energy saving prospects highlighted by these and similar reports have been among the key drivers indicating that improving energy efficiency can assist to mitigate the dangerous effect of anthropogenic climate change. Holmes and Hacker (2007) opined recent impetus seems to have shifted from the desire to reduce costs and conserve limited resources towards curtailing the production of CO₂, which in terms of urgency is of much greater importance. However, it is economic considerations that will always dominate. Generally, the approach of global decision makers and governments towards improving energy efficiency in buildings is aimed at developing policies and measures that are designed to reduce energy consumption (Allouhi *et al.*, 2015). CIBSE (2012) and Allouhi *et al.*, (2015) argued that these policies, though diverse, can be largely divided into three categories:

- Regulatory measures (such as building regulations)
- Soft instruments (these consist mainly of voluntary standards, for example, certifications that go beyond regulatory requirements)
- Economic incentives (such as tax exemptions/reductions and capital subsidies which can encourage the owner to undertake energy saving measures/refurbishments)

2.3 Building Modelling and Simulation

Due to the increasing need to ensure energy efficiency and reduction in CO₂ emissions, building performance modelling has become an integral component of building design (Spitz *et al.*, 2012; CIBSE, 2015). Building simulations or models are powerful computational tools which are generally utilised in the aspect of building design to assess regulatory compliance, evaluate changing weather or climate data on overheating analysis and estimate energy performance, which helps in curbing CO₂ emissions, thermal mass evaluation, etc. (Amoako-Attah and B-Jahromi, 2013). Hence, building energy simulation is a powerful tool that allows a building to be modelled as a complete system, thus accounting for the intricate dynamic thermal interactions in a building's external and internal environments (Hygh *et al.*, 2012).

According to Spitz *et al.* (2012), energy simulation is usually employed to estimate the energy performance of a building and enhance occupants' thermal comfort; it is also used to lessen the building's environmental footprint throughout its entire life cycle and reduce the cost of construction and operation. Due to the recent advancement in building thermal regulations introduced by numerous countries, the energy performance of buildings is rapidly increasing and consequently, an efficient modern building requires almost no energy for heating, compared to a decade ago where heating energy consumption was around 200 kWh/(m²) annually (Spitz *et al.*,

2012). The accuracy of the energy simulation is generally as good as the quality of input data available used for the thermal model (Calleja Rodríguez *et al.*, 2013; Babaei *et al.*, 2015). Therefore, simulation accuracy depends on various dynamic input parameters such as occupancy characteristics and weather data, both of which are difficult to replicate in modelling to match that of the real building, especially at the design stage.

The choice of weather data used for the simulation has a considerable impact on the result. According to Holmes and Hecker (2007), building service engineers can only use the weather data of a year to run building simulations, while the World Meteorological Organisation defines climate as a 30-year period so as to reduce the effect of natural inter-annual differences in the weather data. This poses a question of which year's weather data should be used. Generally, the weather data employed in building simulation models contain hourly records of the core weather variables (like temperature, solar radiation, relative humidity and wind speed) at a location in close proximity to the modelled building (Eames, 2016). Usually, two distinct types of weather files are used to perform building simulation in the UK; these are the Test Reference Year (TRY) and Design Summer years (DSY) (CIBSE, 2017). The weather file of a year that is representative of the weather over a certain number of years is referred to as the TRY, which differs as different countries employ different methods in choosing their TRY (CIBSE, 2009). The weather file comprises the average months chosen from a baseline of historical data (Virk & Eames, 2016). The updated CIBSE TRY files are developed using a baseline period of 1984 to 2013, as opposed to the previous TRY using a baseline of 1984 to 2006, therefore, they account for the effect of climate change (Mylona, 2017). Virk and Eames (2016), highlighted that in the UK, the International Organization for Standardization (ISO) methodology is employed to select suitable TRY months and it selects representative months using air temperature, relative humidity, cloud

cover (as a substitute for global irradiation) and wind speed (as a secondary parameter). The primary variables are used to obtain the three months with the lowest ranking. From these months, the month with the most average wind speed is subsequently selected as the representative month for that location (Virk & Eames, 2016). Since TRY is developed to be representative of weather over certain years, it does not contain extreme scenarios, therefore it is better suited for measuring energy performance and not appropriate for estimating building performance under worst case scenarios like overheating (Holmes and Hecker, 2007; CIBSE, 2009) The updated CIBSE TRY files are developed using the baseline period of 1984–2013 as opposed to the previous TRY using the baseline of 1984–2006; therefore, they account for the effect of climate change (Mylona, 2017). CIBSE introduced the concept of DSY in 2002 to make up for the shortcoming of the TRY weather data and to provide designers with weather data that can be used to evaluate the risk of overheating (CIBSE, 2002). CIBSE (2009), described the DSY is a whole year in which the average temperature of the summer period, April to September (instead of June to August), is at the centre of upper quartile of rankings obtained from 20 individual years. That is, in a 20-year period the DSY will be the third warmest year according to the average April to September temperature. However, observations by researchers and professionals over the years show that the DSY produced using the original selection criteria has some underlying shortcomings (Eames, 2016). A summary of the main problems associated with the original DSY weather file include the following (Eames, 2016):

- The severity issue: this arises as the severity of the DSY differs across all locations.
- The temperature issue: this is evident as the tails of the TRY temperature distribution can be more extreme compared to that of DSY.

- The overheating issue: this arises as using TRY for the simulation of some building types in some locations can result in higher overheating compared to using DSY for the same locations.

These concerns have resulted in the review of the simplistic original DSY selection method. The latest weather data in the UK for London presented in CIBSE TM49 is underpinned by the morphing of historical weather with the latest UKCP09 climate change projections which are probabilistic in nature (CIBSE, 2014). Probabilistic Design Summer Years for London (PDSYs) is provided in CIBSE TM49, which will be extended across the other CIBSE weather locations. The PDSY are selected based on a new metric of summer warmth referred to as ‘Weighted Cooling Degree Hours’ (WCDH), which is associated with the chances of thermal discomfort (CIBSE, 2014). CIBSE (2014) describes WCDH as the cumulative squared hourly difference between the external dry bulb temperature, T , and the adaptive thermal comfort temperature, T_c , whenever T is greater than T_c . This methodology has been developed to replace the original DSY with a set of years that gives better representation of overheating events along with their relative severity and anticipated frequency (Eames, 2016). Moreover, the PDSY developed for London also incorporates the effect of the Urban Heat Island (UHI) observed in London and it is therefore an improvement on CIBSE’s previous current and future weather data (DSY and TRY) developed in 2009, which is underpinned by the UKCP02 (CIBSE, 2014).

The main disadvantages of building simulations include the large amount of input data required, the high technical knowledge and the considerable time needed even for experienced users (Mustafaraj *et al.*, 2014; Babaei *et al.*, 2015). According to CIBSE (2015a), generally, design software for building energy performance is split into two types: compliance evaluation or assessment tools and design tools. Though both categories of software are dynamic thermal

simulation models, they rarely give similar performance results as they are developed to address two rather distinct but inseparable requirements. Factors such as the difference in modelling procedures between getting energy performance requirements satisfying regulation standards and a building's real performance under bespoke climatic conditions and occupancy behaviour are responsible for the discrepancy in performance results obtained from the two model types (CIBSE, 2015). That is, compliance evaluation models usually employ simulation software based on a standardised climate and operational data to satisfy the building regulations, while building design models use a dynamic simulation to estimate building performance under a variety of bespoke dynamic conditions (CIBSE, 2015).

2.3.1 Building energy performance modelling for compliance and actual energy consumption estimation

Building regulations provide the minimum standard for new and existing buildings in the UK. These government set regulations differ marginally for Scotland and Northern Ireland as they are separately overseen. In Wales and England, Part L “Conservation of Fuel and Power” oversees the efficiency of new buildings with extensions such as L2A for new non-domestic building and L2B for work in existing non-domestic buildings (BRE, 2006). New buildings in the UK must be assessed at the design stage with the standardised calculation method known as the ‘National Calculation Methodology’ (NCM) which is the calculation approach required by the EPBD for demonstration of compliance with energy performance standards (Collins, 2012; CIBSE, 2013a; DCLG, 2015).

To show compliance with building regulations, NCM takes into consideration the architectural design, regulated energy use (such as lighting, heating, cooling and domestic hot water

requirements) of the modelled building and offers a comparison between the carbon emissions of the model and a comparable notional building. Both calculations are done using standard sets of data for different activities and call on same service construction databases. The standard NCM templates define the operational inputs (such as operational hours, occupancy density, set temperature points for space conditioning, domestic hot water demand, ventilation rate, etc.) that are used for both the modelled and notional buildings. The NCM enables compliance calculations to be done by endorsed dynamic simulation software (such as Environmental Design Solution LTD EDSL TAS) for large complex buildings or SBEM for less complicated non-domestic buildings. Dynamic thermal simulation software is preferred for complex buildings because it give hourly output, which is needed to give a more accurate evaluation compared to SBEM, which provides a monthly calculation output. As highlighted earlier, the calculation procedure for both alternative dynamic simulation software and SBEM is defined in NCM, which is issued by the UK's government Department for Communities & Local Government (DCLG). Therefore, they use specific weather data and standardised set of activities and construction databases but some unregulated energy use (such as plug loads, catering, lifts, servers, etc.) are not accounted for in the calculation. This makes the building regulation part L energy results not representative of real site energy consumption (CIBSE, 2015). Even though the NCM guidance clearly advises that part L results are not equivalent to a building's actual consumption, they are frequently used as the starting point for computing an actual consumption model and possibly budget planning for utilities use.

On the other hand, bespoke energy models using Dynamic Simulation Models (DSM) can estimate energy consumption that is more representative of actual energy consumption. This is because bespoke analysis enables greater flexibility as usage patterns and internal conditions can be defined

along with systems that are more representative of actual buildings (CIBSE, 2015). It should therefore be noted that within building energy modelling, there are two main evaluation categories that should not be confused, namely modelling for compliance and bespoke modelling. Figure 2.1 shows the major distinction between a DSM compliance energy model and a bespoke model.

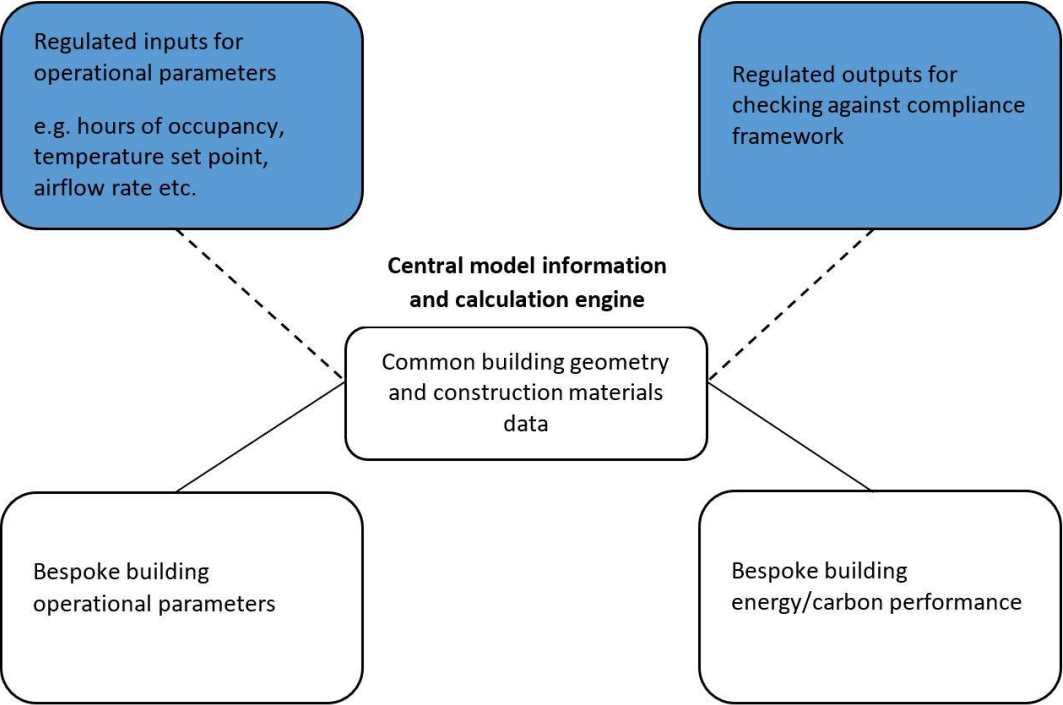

Figure 2.1: Use of common central model for multiple applications (CIBSE, 2015)

However, despite the closer representation of actual site energy consumption that bespoke models offer, there is still existence of a performance gap as the models have limitations. The limitations are associated with the fact that models are always a simplified view of the real world. Additionally, occupants’ behaviour, which is complex cannot be perfectly assumed and weather data used in modelling is usually an average climatic data which will not necessarily be representative of a specific real year etc.

2.3.2 Studies on performance gap and estimation of building energy performance

Studies of available state-of-the-art show that there is significant literature on the discrepancy between the energy model design and the measured energy consumption of operational non-domestic buildings, especially offices. Some of this research is presented in this section along with some studies on the energy performance of hotel buildings.

In the field of building performance gap and estimation of building energy performance, some studies, for instance, those of Menezes *et al.*, 2012; CIBSE, 2013a; Gucyeter and Gunaydin 2012, investigated the reduction of performance gap and development of improved energy simulation model in commercial office buildings. Menezes *et al.*, (2012), used Post Occupancy Evaluation (POE) information of the case study building to investigate the observed performance gap between predicted and actual energy performance. In a similar study, CIBSE, (2013a) TM54 presented with the aid of a case study high density office building, the apparent mismatch between predicted energy performance of a building at the design stage against operational energy. While, Gucyeter and Gunaydin (2012) employed a calibrated simulation model based on an energy performance audit and monitoring of the case study building, which is evaluated on performance levels and potential for improvement with simple Energy Conservation Measures (ECM). Gucyeter and Gunaydin (2012) demonstrated that after 13 runs of repeating the calibration process, a calibrated base-case model with an average root mean square error of 12.45% for heating and cooling energy consumption compared against monitored data was attainable which was finally used to evaluate three retrofit strategies along with several proposed ECMs. On the other hand, the findings of the works of Menezes *et al.*, (2012) and CIBSE, (2013a) both demonstrated the existence and causes of performance gap between models and operational buildings along with methods that can be

employed by building professionals to bridge the performance gap. Menezes *et al.*, (2012), indicated that the major underlining causes are the unrealistic input assumptions of occupancy pattern and facilities management in building energy models. The study also showed that POE can help to significantly reduce this performance gap by employing the data obtained to develop a more representative model of the actual building, which incorporates better parameters with regards to occupancy pattern and unregulated energy use especially small power and catering equipment in high density office buildings. Moreover, the result of CIBSE, (2013a) TM54 showed that energy models that account energy uses, such as such lifts, catering facilities, servers, small power office equipment etc., which are not accounted for in energy compliance models can provide very significant correlation between energy consumption estimates compared to actual operational energy consumption.

Figure 2.2 shows a comparison of the case study result for Part L model and the TM54 estimates against actual measurements from the report.

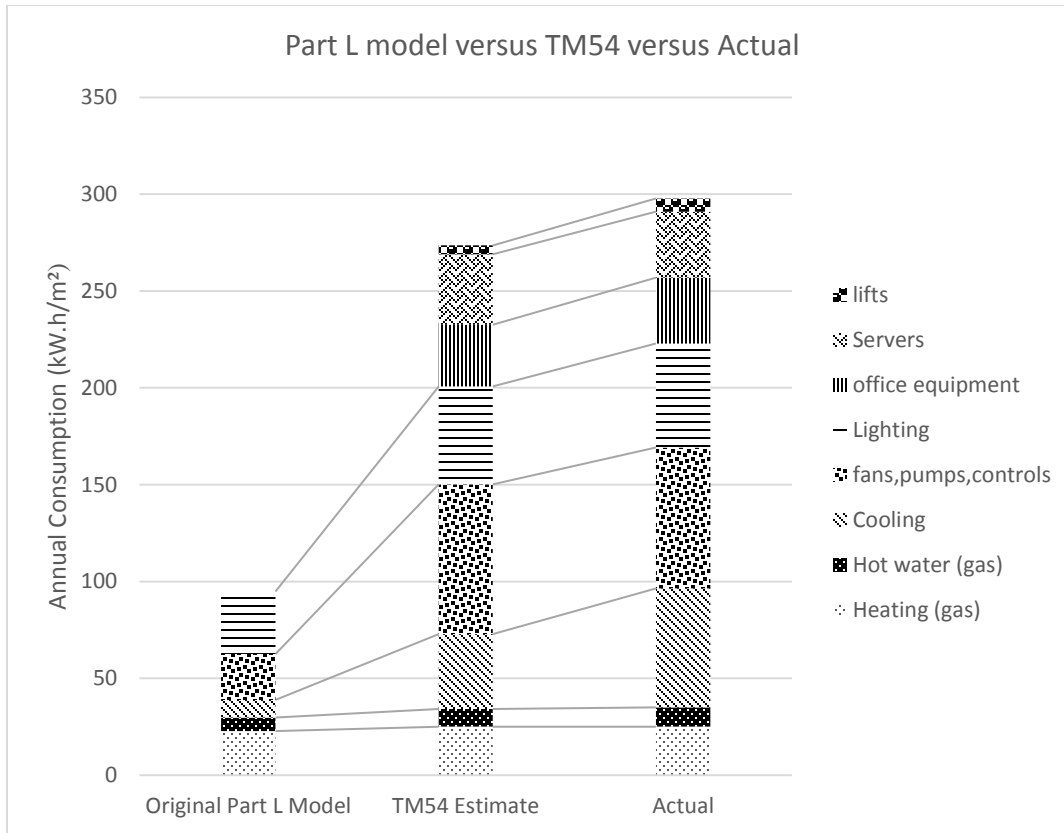

Figure 2.2: Case study result for Part L model and the TM54 estimates against actual measurement (CIBSE, 2013a).

Furthermore, some studies such as those of Knight, Strvoravdis and Lasvaux 2008; Collins 2012 and Xing *et al.* 2015 evaluated comparison of energy simulation models to actual building performance and also highlighted the importance of accurate estimation of building energy consumption in commercial buildings. Knight, Strvoravdis and Lasvaux (2008) compared site measured energy consumption data to predicted values from detailed surveys and modelling for a case study for a mixed-use UK educational building. While Xing *et al.* (2015) evaluated the efficacy of Energy Retrofit Measures (ERMs) in reducing the energy demand of hotel buildings using an existing hotel building in China. Their study was undertaken with a calibrated model on a building simulation software and the energy-saving potential of an articulated retrofit scheme

was evaluated. On the other hand, the work of Collins (2012) highlighted the increasing importance of accurately estimating annual energy consumption within the construction sector while also identifying that the challenges of using available software are associated with their methodologies that are sometimes complex, time consuming and onerous to interrogate and do not automatically produce predictions that are accurate enough. Thus, Collins (2012) presented the use of Heating Degree Days (HDD) computed from simulation weather data as means of monitoring actual performance against predicted heating energy consumption. The result of Knight, Strvoravdis and Lasvaux (2008) provided an understanding as to how close the predictions from available software are to actual energy consumption. Though the paper highlighted the inherent challenges associated with the use of software modelling for evaluating building energy performance, the result of predicted energy from the survey data as well as that obtained using a UK SBEM asset type compliance model compared favourably with the site monitored actual energy consumption profile for the case study building. However, the paper pointed out that further case studies need to be analysed to have any assurance in its findings. Whereas, the results of Xing *et al.* (2015), indicated performance gap between uncalibrated energy model and actual energy consumption, and revealed that internal load schedules along with occupancy rate and the chillers' coefficient of performance (COP) have significant effects on the accuracy of the model for hotel buildings. Furthermore, post-implementation monitoring indicated strong correlations between the prediction of the calibrated model and the actual outcomes of the building energy efficiency retrofit, thus validating the accuracy of calibrated energy models. Moreover, the different findings of these studies presented further highlight the difficulties and challenges of developing accurate building energy models that compares favourably with actual building energy performance.

The work of Deng and Burnett (2000), Priyadarsini *et al.* (2009) and Wang (2012) examined the performance of hotel buildings in different cities located in a cooling dominant climate. Deng and Burnett (2000) used data based on utility billing, augmented by actual site measurements and operational information, to study the energy performance of 16 different hotel buildings in Hong Kong. Their result estimated the Energy Use Intensity (EUI) per unit floor area for all the hotels and examined the correlation between obtained EUI and several factors such as year of construction, occupancy, hotel class and weather. The analysis showed no clear correlation between EUI and the examined factors. Likewise, Priyadarsini *et al.* (2009) used energy consumption data and other relevant information collected from 29 top-class hotels via a national survey in Singapore. The study evaluated the EUI of the hotels and investigated the correlation between electricity consumption and the occupancy of several rooms of the individual hotels. The result showed a weak correlation, which highlights the importance for improved energy management in hotels during low occupancy periods. Additionally, their EUI Pearson correlations with other possible explanatory indicators show that density of workers and years after the previous significant energy retrofit were also observed to be immensely connected to the energy use intensity of the hotels. Wang (2012) conducted a comparable study in Taiwan using data from a bigger sample of 200 hotels comprising 45 international tourist hotels, 19 standard tourist hotels, 116 hotel enterprises, and 20 bed and breakfast properties. Pearson correlations between EUI and possible explanatory indicators showed that certain building conditions, operations, and other factors are significant. Moreover, these studies all highlighted the increasing difficulty of adequately evaluating the energy consumption of hotel buildings due to several reasons. These reasons include the fact that most hotels house several varied facilities such as kitchens,

restaurants, function spaces, retail outlets, swimming pools, etc., along with their significantly varying levels of occupancy even though they normally operate for 24 hours all through the year.

From the review of literature, it is evident that a considerable number of studies have been conducted on improving energy performance prediction especially in the design phase. However, most studies focus on non-domestic office buildings. Furthermore, it can be noted that there is a research gap associated with the evaluation of unregulated energy use estimates.

Table 2.1 Summary table of previous studies on performance gap and estimation of building energy performance

Source	Area of study/ concern addressed	Location
Menezes <i>et al.</i> , (2012)	Reduction in performance gap	UK
CIBSE, (2013a)	and development of improved	UK
Gucyeter and Gunaydin (2012)	energy simulation model for commercial office buildings.	Turkey
Knight, Strvoravdis and Lasvaux (2008)	Energy simulation models compared to actual building and	UK
Collins (2012)	the importance of accurate	UK
Xing <i>et al.</i> (2015)	estimation of building energy consumption in commercial buildings.	China
Deng and Burnett (2000)	Energy performance evaluation	Hong Kong
Priyadarsini <i>et al.</i> (2009)	in hotel buildings and associated	Singapore
Wang (2012)	challenges.	Taiwan

2.4 Measures of Improving Building Energy Performance

It has become apparent from energy consumption data and the literature review, that one of the most feasible and sustainable ways of reducing energy costs and CO₂ emissions is by improving the energy efficiency of new and existing buildings (Juan *et al.*, 2010; Kneifel, 2010). According to Juan *et al.* (2010), globally, there are various organisations that have made considerable contributions to encouraging sustainability in buildings. Some of such organisations include Leadership in Energy and Environmental Design (LEED) established by the US. Green Building Council (USGBC) and BRE Environmental Assessment Method (BREEAM) in the UK, which is an environmental assessment tool to evaluate the sustainability of new and existing buildings. These organisations provide a means of evaluating the environmental burden of buildings, consequently giving insightful information to stakeholders in the built environment on various measures that can be employed to improve energy efficiency in buildings (Juan *et al.*, 2010).

Numerous measures, technologies and approaches have been proposed cumulating from various researches, practical and scientific points of view that can aid the enhancement of building energy efficiency and reducing greenhouse gas emissions. Generally, most of these measures can be grouped as follows (Barlow & Fiala, 2007; Kneifel, 2010; CIBSE, 2012; Fouquier *et al.*, 2013):

- Raising awareness amongst occupants about the need to reduce building energy consumption and its impact on the environment. Modest behavioural changes such as unplugging unused devices, configuring idle computers to hibernate, space heating behaviour, reducing domestic hot water wastes, etc. can considerably reduce building energy consumption.
- Introduction of energy efficient improvements and technologies which are above or comply with building regulations in new building design or in the refurbishment of existing ones.

Choice of energy efficient improvements are sometimes not obvious and must be undertaken holistically with caution to avoid the risk of producing reverse effects. However, improvements such as changing to energy efficient lighting, exterior insulation and replacement of single glazing windows with double or triple glazing based on room exposure are normally favoured.

- Ensuring the use of the most energy efficient and optimized plants. Integration of renewable and onsite generated energy sources such as solar energy, CHP cogeneration or tri-generation systems can be quite efficient.
- The use of effective system controls and monitoring that ensures energy efficient and cost-effective operation of the systems though permitting individual occupants to change their peculiar comfort levels but preventing systems to be ‘on’ by default.

Some literature on the energy efficient measure investigated in this report is presented in subsequent sections.

2.5 Building Façade and Window Glazing

The building envelope, façade and especially the window have significant impacts on the thermal performance of a building (Hee *et al.*, 2015). It has become very crucial that an energy efficient façade is used in order to reduce the CO₂ emissions throughout the operational life cycle of a building (Ihara *et al.*, 2015). According to IEA (2013b), the façade of a building dictates the proportion of energy required for heating and cooling a building and hence, a more efficient building envelope is crucial to reducing building energy consumption. For instance, in a cold climate, a building with a high-performance envelope needs just between 20% to 30% of the heating energy requirement of the current average building in the OECD countries while, in hot

climates, a possible energy saving of between 10% and 40% is estimated from reduced energy requirements for cooling (IEA, 2013b).

Windows are the most common fenestration style and serve a variety of important functions in buildings which include: providing occupants with a connection to the external environment, providing thermal comfort, optimum illumination levels, air ventilation, passive solar gain and possible avenue to exit the building in extreme scenarios (Huang *et al.*, 2014; Cuce & Riffat, 2015). They are a popular architectural form and the open scenery through windows in cities with high-rise buildings is a very desirable feature (Huang *et al.*, 2014). However, windows have a considerable effect on a building's energy consumption due to their relatively higher U-values compared to other components in the building envelope (Cuce & Riffat, 2015). Therefore, the thermal performance of glazing materials is an important issue within the built environment.

Bahaj *et al.*, (2008) and Huang *et al.*, (2014), highlighted that façade and glazing material characteristics associated with energy performance are thermal quantities such as thermal transmittance (U-value) and solar heat gain quantities such as Solar Heat Gain Coefficient (SHGC). According to BRE (1998), the U-value of a material is the measure of heat transmitted by the material either into or out of the building envelope. The SHGC or the G-value gives a measure of how much of the sun's energy hitting the glazed surface is transmitted through it (Ander, 2014). Recent technological advancements have resulted in the availability of high performance, energy efficient window and façade glazing systems that significantly improve the thermal performance of glazing. These advancements produce glazing with lower heat loss, less air leakage and warmer window surfaces, which enhance comfort and reduce condensation (Ander, 2014). Generally, high performance window and façade glazing have double or triple glazing, specialised transparent coatings, with insulating gas inserted between panes and improved frames

(BRE, 1998; Ander, 2014). Ander (2014), opined that during design, the choice of windows and façade glazing systems must be weighed holistically with choice depending on various factors which include building type, local climatic condition, and building orientation. Additionally, retrofitting of window or glass films can also be applied to existing buildings as a cost-effective way of altering thermal performance as they can help to reduce solar gains and glare.

Currently, the use of highly glazed facades is widespread in high-rise and commercial buildings due to the short application time and because they are easy to maintain, lightweight, have an aesthetic value and are durable (Cetiner & Özkan, 2005). However, an extensive glass curtain wall can result in significant energy consumption due to high solar thermal gains or considerable night heat loss in a cold climate (Ghaffarianhoseini *et al.*, 2016). Cetiner and Özkan (2005) and Ghaffarianhoseini *et al.* (2016), argued that to tackle these challenges various intelligent façade systems/technologies, such as the double-skin façade (DSF) have been proposed as an effective solution to improve the thermal performance of a glazed façade. According to Cetiner and Özkan (2005), a DSF system consists of two glasses of one or multilevel skins or façades with a large cavity in between. This intermediate airgap acts as a thermal buffer zone and is normally characterised by controllable shading and ventilation systems. Application of DSF systems have become gradually popular in Europe since the mid-1980s (Chou *et al.*, 2009) and some of the advantages of DSF systems include:

- The architectural benefit as a mono-material that provides an open and transparent façade (Høseggen *et al.*, 2008)
- Cetiner & Özkan (2005) and Ghaffarianhoseini *et al.*, (2016), highlighted that the ability to reduce heating requirements and to serve as protection against the external environment. The airgap in DSF acts as a buffer zone and preheater for

ventilation air, thereby improving thermal comfort during cold winters as the inner skin remains warmer. Additionally, the inner skin casement can allow for natural ventilation in high-rise buildings that are exposed to extreme wind or buildings where this will normally not be possible due to high external noise levels

- Further advantage can be derived from the applicability of effective sun-shading devices that are protected from adverse outdoor weather within the DSF cavity (Høseggen *et al.*, 2008).

However, some of the disadvantages associated with DSF need to be thoroughly considered to ensure the possible merits of reducing energy consumption are not negated. Høseggen *et al.* (2008) and Ghaffarianhoseini *et al.* (2016), discussed that the demerits of DSF include: the considerably high investment cost compared to a conventional single façade, excessive heat gain owing to its high U-value, overheating risk on sunny hot days or warmer climate, which can lead to a higher cooling load and associated thermal discomfort due to asymmetric thermal radiation. However, the overheating risk can be reduced with properly dimensioned openings and the provision of an optimum cavity space between the façade and properly positioned shading device.

2.5.1 Studies on the impact of window glazing and glazing energy improvement measures

Studies of available state-of-the-art shows that there is a significant amount of literature on the impact of window glazing and glazing energy improvement measures on the energy and thermal performance of building envelopes. Some of these studies are presented below.

In the area of window glazing energy improvement, some studies such as, those of Dussault *et al.* (2012); Chen *et al.* (2012) and Cuce and Riffat (2014) evaluated and reviewed different window energy improvement measures. Dussault *et al.* (2012) and Chen *et al.* (2012) both investigated the

use of different energy improvement technologies to improve the energy consumption of buildings due to the negative effect of windows with Dussault *et al.* (2012) examining the energy savings potential of incorporating smart window technologies in a double glazed window pane of a typical low thermal mass office building in Quebec, Canada. While Chen *et al.* (2012) investigated the effectiveness of different external window shading types on reducing the cooling energy consumption of varied types of commercial buildings in five different climate zones in China with the aid of a building simulation model of a calibrated prototype model. One of the key findings of Chen *et al.* (2012) indicated that for both economical and energy saving reasons, flexible (opaque) shading is recommended in high rise office and hotel buildings across the varied climate zones. On the other hand, Cuce and Riffat (2014) conducted a comprehensive review of the latest advancements in glazing technologies while giving an insight into possible future glazing innovations. Their review noted the significant CO₂ emission reduction opportunities available through the improvement of thermal performances of glazing components of the building envelope, since the researchers have indicated that about 60% of thermal loss through a building envelope is through the window. Additionally, the key findings of the study show that currently available high-performance double and triple multilayer products are popular due to their cost effectiveness, although vacuum and aerogel glazing could become more acceptable due to their superior energy performance along with other cost-effective novel windows such as vacuum tube and solar pond windows. Similarly, the work of Dussault *et al.* (2012) highlighted that Smart windows have controllable absorbing layers, which enable the optical properties of window panes to be altered based on optimal requirements for light and heat flux penetrating the building. Moreover, their study result showed that optimizing the solar heat penetration based on the

required heating, cooling and lighting demands helps to considerably reduce the annual building energy consumption and maximum cooling loads.

Furthermore, in consonant with studies on enhancing the energy performance of window glazing, the research of Li *et al.* (2015), Yousif (2012) and Yin, Xu and Shen (2012) investigated the potential of solar window films to reduce the energy consumption of varied types of commercial buildings in three different climates. The work of Li *et al.* (2015) employed a methodology which involves an experimental chamber where actual measurements are taken and are subsequently validated with a computer simulation to examine the impact of different types solar window films on the energy consumption of various function rooms in commercial buildings under the relatively warm Hong Kong climate. Their result indicated that the application of window films to functional rooms of commercial buildings produces good energy saving results with the best performance found in office buildings. Additionally, the results showed that window films application on clear glazing performs better than on tinted glazing. In contrast, Yin Xu and Shen (2012) used two case study non-domestic buildings in a hot summer- cold winter climate to investigate the possible energy savings accruing from the application of window films software building simulation of the whole building with and without solar films. Their outcome indicated that the performance of window films in glazed curtain wall windows varies and it is mainly influenced by the position of the installed film, window sizes and arrangement. Their result also showed that window films can reduce the shading coefficient and solar heat gain by up to 44% and 22% if applied on the outside and inside of existing windows. On the other hand, Yousif (2012) used a spectrophotometer to measure key parameters for glazing performance for two case study rooms in a relatively hot all year round climate. The case study rooms included one with and the other without a window film to calculate the effect of window films on controlling heat gain. The study's key finding indicated

that window films reduced the summer cooling load but also resulted in an increased winter heating load; however, the magnitude of the increased heating load was lower.

Similarly, the works of Carrier *et al.* (1999), Huang *et al.* (2014), Yang *et al.* (2015) and Vanhoutteghem *et al.* (2015) worked on improving the energy performance of windows and widow glazing by investigating the effectiveness of different glazing and window design systems under different climates with the aid of building simulation software. With Huang *et al.* (2014) examining the efficacy of different energy efficient building window designs in cooling dominant climates. The result of their study indicated that low emissivity glazing produces the best performance amongst the investigated design options; conversely, double-layer glazing gives the worst performance. They also found that energy-efficient designs on east and west orientations are the most economical in relatively hot climates. Carrier *et al.* (1999) studied the efficacy of window glazing in reducing a building's solar heat gain using the well-known DOE-2 software. One of their main findings indicated that cooling energy reduces with the number of glazings and therefore the overall energy demand of the building is reduced. However, the effect of important parameters such as wall-to-window ratios or shading coefficients on solar heat gain in the building was not investigated in that research. Whereas Yang *et al.* (2015) investigated the optimal window-wall ratio and the adequate glazing type in varied air-conditioning system operation modes of domestic buildings for individual orientation in a hot summer-cold winter climate. Their result indicated that overall energy consumption increased with an increasing window-wall ratio, especially for east- or west-oriented windows. Additionally, they claimed that low-emissivity panes have better energy efficiency performance compared to hollow glass. Moreover, Vanhoutteghem *et al.* (2015) investigated the link between size, orientation and glazing characteristics of windows for different side-lit rooms in a 'nearly zero-energy' residential buildings in a heating dominant climate. One

of their key findings indicated that the best energy saving potential and solar heat gain utilization was observed in south-oriented rooms. Additionally, their result suggested that to achieve a reduction in the room heating load in north- and south-oriented rooms with a large window area, low U-values are required.

Some studies on evaluation of the impact of windows on building energy performance, such as those of Sorgato *et al.* (2016); Wang and Greenberg (2015) and Ihara *et al.* (2015) focused and worked on the effect of window properties and ventilation operation on the energy and thermal performance of buildings using dynamic building simulation software. The work of Wang and Greenberg (2015) evaluated the effect of window operation on occupancy thermal comfort and building energy consumption using a simulated reference office building in three different climate zones of the United States. The result of the study, which investigated the relationship between Variable Air Volume (VAV) systems and different ventilation control measures, highlighted that optimal window operation can produce HVAC energy savings of up to 17-47% with mixed mode ventilation during summer for various climates. On the other hand, Sorgato *et al.* (2016) focused on the impact of occupant behaviour regarding window operation on the HVAC energy consumption of dwellings in Brazil. Their results highlighted that medium thermal capacity buildings with proper ventilation control have more potential to provide occupant thermal comfort. Moreover, adequate building ventilation accomplished via automated ventilation control coupled with medium thermal inertia produced a decrease in HVAC energy consumption. In contrast, Ihara *et al.* (2015) worked on improving building energy efficiency by implementing a different façade in a cooling-dominant climate. The study investigated the impact of four important façade properties associated with its energy-efficiency. This was undertaken to evaluate the effect of these properties in reducing the cooling and heating energy loads of a case study office building. The

key findings of the study indicated that a reduction in the SHGC and window U-values along with an increase in solar reflectance of the opaque part are potential solutions for reducing the energy demand. These studies provide an understanding of how different window properties and ventilation operation can impact building energy performance and efficiency.

Table 2.2: Summary table of previous studies on the impact of window glazing and glazing energy improvement measures

Source	Area of study/ concern addressed	Location/Climate
Cuce and Riffat (2014)	Evaluation of different glazing energy improvement technologies.	EU [Sub-tropical climate]
Dussault <i>et al.</i> (2012)		Qubec, Canada [Humid continental climate – heating-dominant]
Chen <i>et al.</i> (2012)		China [across the 5 different climatic zones of China, namely, severe cold region, hot summer-cold winter region, hot summer – warm winter region and mild region]
Li <i>et al.</i> (2015)	Potential of solar window films to reduce the energy	Hong Kong [warm climate]

Yousif (2012)	consumption of commercial	Iraq [Hot climate]
Yin, Xu and Shen (2012)	buildings in different climates	China [Hot summer – cold winter region of China]
Ihara <i>et al.</i> (2015)	Effect of different window properties and ventilation operation on building thermal performance and energy efficiency	Japan [Humid subtropical climate with hot summer – mild winter]
Sorgato <i>et al.</i> (2016)		Brazil [Tropical climate]
Wang and Greenberg (2015)		USA [Temperate climatic region of the USA]
Carrier <i>et al.</i> (1999)	Effectiveness of different energy efficient window glazing and design	Canada [Humid continental – heating dominant climate]
Huang <i>et al.</i> (2014)		Cooling dominant climate of 4 cities in the northern hemisphere – Hong Kong, Singapore, Miami and Houston
Yang <i>et al.</i> (2015)		China [Hot summer – cold winter region of China]

Vanhoutteghem <i>et al.</i> (2015)		Denmark [Temperate – heating dominant climate]
------------------------------------	--	--

2.5.2 Studies on the impact of glazed building façades on building energy performance

Evaluation of available state-of-the-art shows that there is a significant amount of literature on the impact of glazed building facades on the energy and thermal performance of building envelopes. Some of these studies are presented below.

In the field of glazed building façades and their effect on building energy performance, some studies such as, those Gratia and De Herde (2004a) and Aksamija (2017) investigated the effectiveness and behaviour of different glass façade systems. Gratia and De Herde (2004a) investigated the impact of a south DSF on the thermal behaviour (heating and cooling demand) of a case study office in Belgium using a building simulation software TAS. While, Aksamija (2017) evaluated the thermal behaviour and energy performance of different types of DSF systems in the different climate zones of the USA, including heating-dominant and cooling-dominant climate zones. The study employed building energy modelling to investigate the energy performance of a south-facing office space for the different climatic zones. The work Gratia and De Herde (2004a) presented analysis of critical periods of the seasons for the DSF corresponding to sunny and cloudy spring, summer, autumn and winter days. Their case study results illustrated that the application of DSF reduces the winter heating loads and increases the cooling loads during summer. However, they did not investigate the effect of the DSF on the overall energy consumption. On the other hand, one of the key findings of the study of Aksamija (2017) demonstrated that all types of DSF

considered generally provided improved energy performance relative to a single glazed curtain wall base model with varying energy savings dependent on climatic condition. Furthermore, the study showed that heating loads and cooling loads are substantially reduced in heating-dominant climates, while, cooling loads are also reduced in cooling-dominant climates. However, the study did not consider the option of mechanical ventilation of DSF cavity in overheating scenarios as only natural ventilation of air cavity was investigated.

Similar research works, for instance, those of Hoseggen *et al.* (2008) and Gelesz and Reith (2015) both evaluated the application of DSF on building energy performance in different climates of Europe with the aid of a building simulation software. With Hoseggen *et al.*, (2008) investigating the implementation of DSF in Norway (heating-dominant climate); the DSF was applied to the east façade to optimise energy consumption reduction. The key findings of their work demonstrated that, even though the heating was 20% higher for a single façade with basic window attributes, the use of improved U-value windows with the single façade produced a close energy performance compared to that of the DSF solution. Hence, the predicted DSF energy savings are marginal, making the application of the DSF unprofitable. Comparably, Gelesz and Reith (2015) evaluated the energy performance of a DSF compared to that of a double and triple glazed single façade in Hungary, which is considered to be a Central European moderate climate region. The DSF evaluated is characterised by a buffer mode window and a naturally ventilated outdoor air curtain box type window for the winter and summer period respectively. The main finding of the study indicated that outdoor air curtain mode DSFs have a promising prospect of reducing energy consumption compared to the single skin façade substitutes in Central Europe although the observed energy savings are marginal with a cooling energy saving of 7%.

Furthermore, in consonant with studies on enhancing the energy performance of glazed building façade, the research of Gratia and De Herde (2004b) and Hien *et al.* (2005) evaluated the effect of DSF and the varied ventilation system on the energy performance of case study office buildings under different climatic conditions, with the aid of building simulation software (TAS). Hien *et al.* (2005) investigated the impact of DSF ventilation strategies on energy consumption in a tropical humid climate and their result indicated that naturally ventilated DSF were able to reduce energy consumption and also provide improved thermal comfort. Additionally, extraction fans were able to minimize condensation induced by high humidity. It is worth noting that their work did not consider building orientation whereas Gratia and De Herde (2004b) investigated the energy performance of a DSF with mainly natural ventilation coupled with the DSF orientation and wind speed in a temperate climate. One of their key findings indicated that night ventilation is more effective than day ventilation as it allows for a considerable reduction in building cooling loads. Additionally, the use of shading is relatively more effective in a single glazed building.

Similar studies, such as those of Fallahi *et al.* (2010) and Parra *et al.* (2015) both worked on improving the thermal performance and energy efficiency of DSF systems with the use of numerical modelling techniques. Fallahi *et al.* (2010) presented an approach of introducing thermal mass with the DSF and the energy performance evaluation of its impact on an adjacent study room was done using a verified numerical model. Their parametric study result shows that the introduction of thermal mass in the cavity space with mechanical ventilation gives significant energy reduction. Moreover, depending on configuration, up to 26% summer energy saving and up to 59% winter energy saving is obtainable relative to a conventional DSF without thermal mass. In contrast, Parra *et al.* (2015) used Computational Fluid Dynamics (CFD) to investigate the

effectiveness of a Venetian Blinds (VB) shading device on improving the performance of the DSF. One of their key findings shows that VB can reduce solar heat gain by up to 35%.

Table 2.3: Summary table of previous studies on the impact of glazed building façade on building energy performance

Source	Area of study/ concern addressed	Location/Climate
Gratia and De Herde (2004a)	Application, effectiveness and behaviour of different glass façade systems	Belgium [Temperate maritime climate]
Aksamija (2017)		USA [different climate zones of the USA, including heat-dominant and cooling dominant climatic zones]
Hoseggen <i>et al.</i> (2008)		Norway [Temperate climate]
Gelesz and Reith (2015)		Hungary [Temperate continental with cold winters and warm summer]
Gratia and De Herde (2004b)		Belgium [Temperate maritime climate]

Hien <i>et al.</i> (2005)	Effect of DSF cavity ventilation systems on building energy performance in different climate	Singapore [Tropic humid climate]
Fallahi <i>et al.</i> (2010)		Sample weather file representing extreme summer and winter conditions
Parra <i>et al.</i> (2015)		Spain [Mediterranean climate]

From the review of state-of-the-art, it is observed that there are many varied studies on improving the energy performance of windows and façade glazing. However, most studies are on commercial office buildings and dwellings, with the majority of them using prototypical or reference rooms as case studies in mainly cooling dominant climates. Also, in the review of state-of-the-art of studies on the energy and thermal performance of DSF, most studies in this area use commercial office building and prototype buildings as case studies or CFD modelling of mainly the DSF cavity.

2.6 Combined Heat and Power (CHP)

The quest to find different strategies for reducing the UK’s carbon footprint has driven several government agencies, institutions and bodies to evaluate different alternatives to the way in which energy is produced, as it has a substantial impact on GHG emissions (Nock *et al.*, 2012). Globally, the typical energy efficiency of traditional fossil-fuelled power plants is around 35-37%, with about two-thirds of the remaining energy lost as wasted heat (International Energy Agency, 2008;

Zhang *et al.*, 2016). Even further losses of about 9% occur during the transmission and distribution of electricity to the end users (International Energy Agency, 2008).

Increasing the use of CHP systems has been acknowledged as one of the possible means of attaining CO₂ emissions reduction and it represents a sequence of proven, dependable and cost-effective technologies that can make significant input to attaining thermal and electricity requirements (International Energy Agency, 2008). Whilst there are improvements in boiler and power station efficiency, CHP can provide a potential saving in primary energy consumption of up to 30%. Even if boiler efficiency is assumed to be up to 85% and the efficiency of a traditional power supply improves to 45%, the primary energy savings of CHP would still be around 23% (CIBSE, 2013b). Moreover, CHP installations can operate using different fuel sources such as natural gas, diesel, biogas and other renewable energy sources with good reliability and a factor of availability of over 90% (Action Energy, 2004).

2.6.1 Definition of CHP

Mago and Smith (2012), defined CHP system as a form of energy production and distribution system consists of a drive system that produces electricity for use in a building and gives heat as a by-product. The heat energy is recovered and utilised to provide space heating or domestic hot water (cogeneration system) for the building, or employed for space cooling in a combined cooling, heating and power system (tri-generation systems). Similarly, EPA (2018) defines CHP as a technology that provides energy efficiency due to its capacity to generate electricity and capture the heat that would have been wasted to provide thermal energy that can be used for industrial operation space heating, cooling and domestic hot water. Additionally, CHP is usually applied in facilities with a substantial demand for thermal and electricity requirement; it can be

located in individual buildings or be a district energy or utility resource. Figure 2.3 shows a common configuration of a CHP:

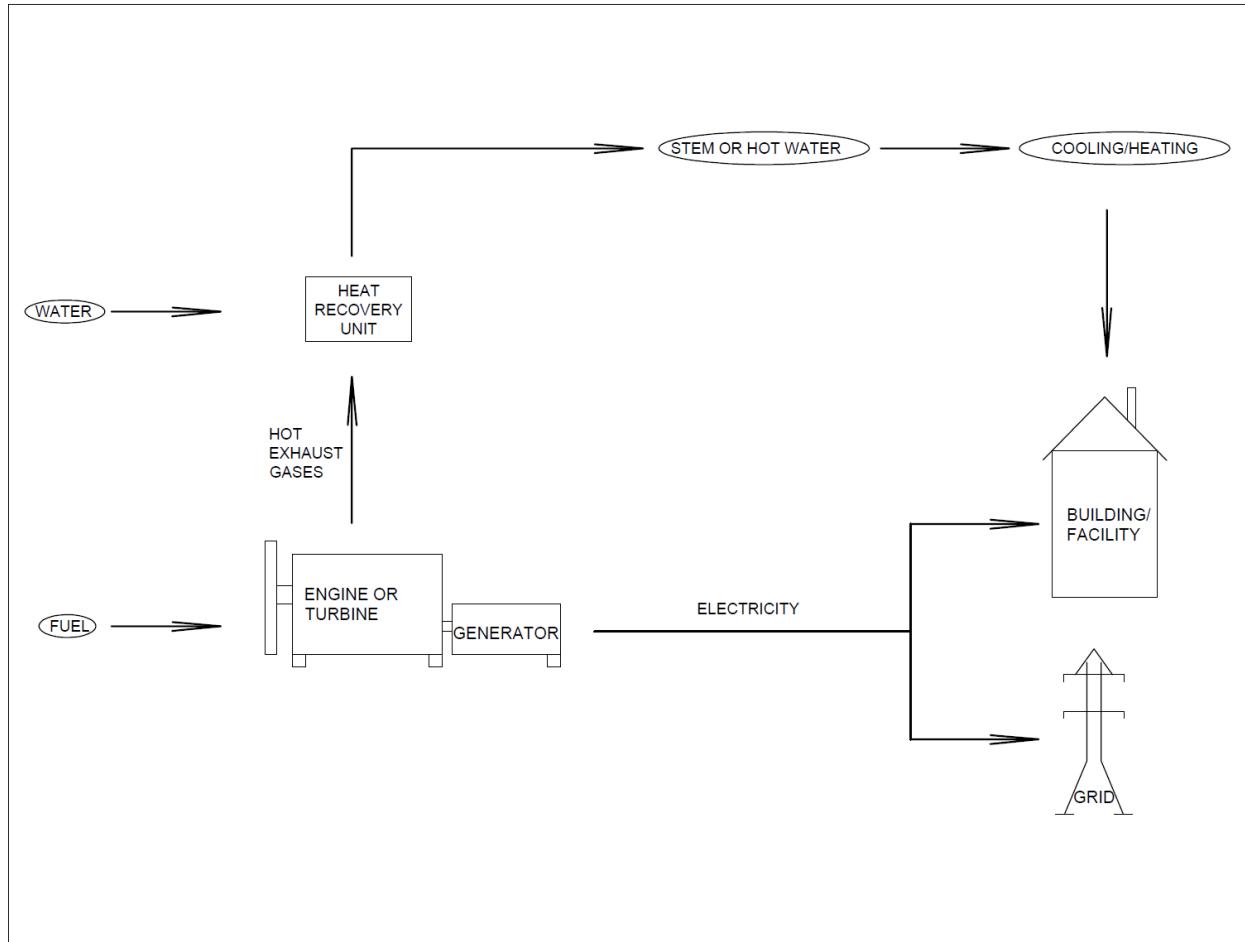

Figure 2.3: Typical CHP configuration (EPA, 2018)

According to the Carbon Trust (2010), the engine, also referred to as the prime mover, is at the heart of CHP installation as it provides the mechanical power to drive the electrical generator and produce heat. This engine is commonly a gas turbine, steam turbine or an internal combustion engine, and has the capacity to run on different types of fuel and satisfy several heat demands, either in the form of hot water or steam. Consequently, this enables CHPs to be especially flexible

and customisable to the needs of individual sites across a broad range of sectors and can offer economical energy solutions for both large and small-scale energy consumers.

2.6.2 Types of CHP and applications

There are different types of CHP and they are normally classified based on their capacity and application. Action Energy (2004), Carbon Trust (2010) and CIBSE (2013) described some of the different types of CHP and their applications, which are presented in Table 2.1 below:

Table 2.4: Types of CHP and application

CHP Classification	Description	Common application	Types of plant
Large-scale CHP	Large-scale CHPs are usually custom-built and are mainly employed in large scale industrial applications. The typical electrical power output of the custom-built CHP ranges from around one megawatt of electricity (MWe) to over 100MWe.	Large scale CHPs are typically used in industrial installations (such as chemical industries, oil refineries, paper mills and food or drink processing factories) and large-scale community/district heating systems in hospitals or on university campuses. Large-scale CHP installations account for	The common types of prime movers found in custom-built CHPs are steam turbines, gas turbines, Combined Cycle Gas Turbines (CCGTs), Organic Rankine Cycles (ORC), Sterling engines, and fuel cells.

		<p>more than half of the CHP electrical capacity in the UK, majorly in chemicals, oil refineries and the paper and publishing sectors.</p>	
<p>Small-Scale CHP</p>	<p>Small-scale CHPs are commonly composed of packaged CHP systems. Packaged CHPs are generally supplied ready for installation as a complete unit. Their typical electrical power output is less than 1MWe. Unlike the custom-built systems of large-scale CHPs, the packaged CHP systems are designed to be modular and are produced on a</p>	<p>Small-scale CHPs are mainly applied in commercial buildings, small scale industrial sites, hotels, schools, hospitals, hostels and leisure centres.</p>	<p>The common types of prime movers used in small-scale packaged CHP systems are gas or diesel compression-ignition engines, Stirling engines and fuel cells.</p>

	larger scale, consequently benefiting from economies of scale.		
Micro-CHP	A micro-CHP is also commonly supplied as a packaged CHP unit, but they are smaller in size with a typical electrical output of less than 50kWe.	Micro CHP systems are used in domestic buildings and very small businesses such as elderly care homes and small leisure centres.	The types of prime movers used in micro-CHP systems are gas or diesel compression-ignition engines, Stirling engines and fuel cells.

There are mainly five types of prime mover technologies used in CHP systems (Carbon Trust, 2010; EPA Combined Heat and Power Partnership, 2015) which include the following:

- Internal combustion engines:** This technology is commonplace and uses the conventional engines found in cars, trucks, trains and small electricity generators to provide the mechanical energy which is converted in the CHP to run on natural gas or compression-ignition engines (Department of Energy and Climate Change 2008a; EPA Combined Heat and Power Partnership, 2015). The size of these engines range between 75kWe to 1.5MWe with a typical electrical efficiency of 25 to 40%, which usually decreases with size (Carbon Trust, 2010).

- **Gas turbines:** EPA Combined Heat and Power Partnership (2015) describes this technology is the same as that used in jet aircraft and other aero-derivative gas turbines adopted in stationary applications. The technology employs a steady stream of burning fuel to propel a turbine, hence generating the mechanical power for the CHP and the heat from the exhaust gases of the turbine is collected for space or process heating (Carbon Trust, 2010). Their capacity is usually larger than 1MWe; however, they are now available in smaller capacity (micro-turbines) of between 80kWe in some packaged CHP systems (Action Energy, 2004; DECC, 2008a). Furthermore, they have a typical electrical efficiency of between 25% for mini turbines to around 36% for very large turbines of above 100MWe (Carbon Trust, 2010).
- **Steam turbines:** This technology drives a turbine with the aid of a steady stream of high-pressure steam produced in a boiler (Carbon Trust, 2010). They are commonly used in industrial applications (EPA Combined Heat and Power Partnership, 2015), but they have lower electrical efficiency in contrast to gas turbines, which operate at higher temperatures (Carbon Trust, 2010).
- **Combined cycle gas turbine systems:** Carbon Trust (2010), these technologies are also usually used in the large-scale generation of power. They use the high temperature waste heat from a gas turbine to produce high-pressure steam which is then conveyed via the steam turbines to produce more power (General Electric, 2018). Additionally, these technologies deliver electrical efficiency with a relatively higher efficiency of over 50% (General Electric, 2018).

- **Fuel Cells:** According to Action Energy (2004) and DECC (2008a), these technologies produce electricity directly from an electrochemical device that combines hydrogen fuel and atmospheric oxygen; some waste heat and water is also produced by this, electrochemically oxidising fuel. Fuel cells are practically pollution free as they run without combustion, especially where hydrogen is obtained from non-fossil sources (Action Energy, 2004). They have the potential to be a viable alternative to reciprocating engines and gas turbine CHP as they provide higher electrical efficiency, but they have a much higher capital cost than traditional gas engines and a relatively shorter expected life span.

2.6.3 CHP financing

There are several financing options for CHP installation depending on the availability of capital and the degree of risk the end-user is willing to take (DECC, 2008b). The financing options are equipment supply financing, capital purchase and an energy supply contract, which can be divided into two main categories: ‘on-balance sheet’ or capital purchase financing and ‘off-balance sheet’ or operating lease financing (DECC, 2008b and Carbon Trust, 2010). DECC (2008b) and Carbon Trust (2010) described the different options of CHP financing and possible funding sources which are presented in Table 2.2 below:

Table 2.5: CHP financing options

On-balance sheet financing	
Description	Funding sources
<p>This financing option is also termed as capital purchase and it reflects on the balance sheet of the company as a fixed asset. This financing approach usually provides the most benefit, but it is equally accompanied by all the risk. It is commonly funded by internal funding, external finance or a combination of both.</p>	<p>Internal funding: this occurs when the end-user provides the capital for the installation, hence fully retaining ownership of the project and deriving the most benefit. However, the end-user bears all the technical and financial risks, which vary with the chosen option of installation.</p> <p>Debt financing: this is when the installation is funded with a combination of new debt and internal funding. The end-user keeps the entire benefits of the installation while still bearing the residual technical and financial risks apart from those that rest with the suppliers. Care should be taken to ensure that the new debt is long-term and matches the long-term nature of CHP projects.</p> <p>Leasing: this funding source offers the end-user a financial arrangement that enables the CHP asset to be used over a fixed period. This arrangement can include a hire purchase, a finance lease (also referred to as ‘lease’ or ‘full pay-out lease’) and an operating lease (also referred to as ‘off-balance-sheet lease’).</p>

Off-balance sheet financing

Description	Funding sources
<p>Unlike the on-balance sheet financing option, this approach does not appear on the balance sheet of the company as a fixed asset. This financing approach also considerably reduces the technical and financial risks borne by the end-user. However, the end-user only retains some of the benefits. Equipment supply finance, Energy Service Company (ESCO) and Private Finance Initiative (PFI) are typical forms of an off-balance sheet CHP financing approach.</p>	<p>Equipment supplier finance: this approach can provide a viable alternative to outright capital purchase of a CHP, as it offers a leasing arrangement where the CHP is usually, designed, installed, maintained and sometimes operated by the equipment supplier. Typically, the arrangement involves the supplier providing the energy to be supplied at prices that include agreed discounts on the open market rate. Therefore, the end-user pays for the fuel and buys the CHP generated power and heat at the agreed price. This options transfers most of the associated risk to the equipment supplier, but the savings accruing to the end-user are also considerably reduced in contrast to an outright capital purchase approach. Additionally, this financing approach is commonly used to finance small, packaged engine-based CHP systems.</p> <p>Energy Service Company (ESCO): ESCOs are companies that offer a total energy supply service, bearing the responsibility for delivery, financing, operation and maintenance of energy facilities. ESCO arrangements vary widely and savings for CHP installations via an ESCO arrangement are usually lower than those of an outright</p>

	<p>capital purchase. An ESCO contract and finance are not mostly connected, as the end-user can still benefit from the principal advantages of an ESCO arrangement irrespective of the chosen financing route.</p> <p>Private Finance Initiative (PFI): This option applies to public-sector organisations installing a CHP. The public-sector organisation signs a contract with a private sector consortium which is typically formed with the explicit goal of providing PFI. The PFI normally consists of several private sector investors including building construction and refurbishment firms, CHP suppliers and even banks. The consortium uses their funding to build the facility, undertake maintenance and undertake capital replacement during the lifespan of the contract.</p>
--	--

2.6.4 Benefits of CHP

CHP systems are appealing because of their potential to deliver several environmental, energy and economic benefits. The advantages of CHP systems result from their capability to produce onsite energy without wasted heat; transmission and distribution losses associated with traditional power plants (International Energy Agency, 2008). Mago and Smith (2012), Nock *et al.* (2012) and the International Energy Agency (2008) presented some of the benefits of CHP systems which include:

- Reduced cost for energy end users
- Reduced CO₂ emissions

- Increased power reliability and security due to the ability of CHP to operate independently from centralised grid systems.
- Reduced dependence on fossil fuels and increased use of alternative energy resources such as municipal solid waste, biomass and geothermal resources in district heating/cooling systems
- Reduced primary energy consumption and improved power quality.

Apart from the reduction in energy utility cost from the application of CHP, it also offers additional financial incentives, especially if it is certified as a ‘Good Quality’ CHP under the CHP Quality Assurance Programme (CHPQA), and this can ease this tax liabilities of the end-user Department for Business, Energy & Industrial Strategy (BEIS, 2016a). The CHPQA is a voluntary initiative set out by the government to offer a practical and determinate process for appraising CHP of various types and sizes in the UK, with the aim of monitoring and improving the quality of UK CHP (BEIS, 2017a). Moreover, CHPQA assesses CHP schemes based on their energy efficiency and environmental performance, which guarantees that the economic benefits are associated with environmental benefits. BEIS (2017a), discussed that CHP schemes certified under this initiative qualify for several benefits, including:

- **Renewable Heat Incentive:** this programme is available to both domestic and commercial buildings in the UK and is set out to incentivise them to adopt renewable or low carbon heat technologies. Under this programme, they are eligible to receive cash payments over a period of time to help to offset the cost of the installation.
- **Carbon Price Floor (heat) relief**

- **Climate Change Levy CCL exemption (in relation to electricity directly supplied):** CCL is primarily a tax on the energy provided to commercial energy consumers in the UK, and CHP use can qualify an end-user for reductions on this payment
- **Enhanced Capital Allowances (ECA):** this is beneficial to end-users that pay corporation tax as they are eligible to claim ECA on any ‘Good Quality’ CHP installation.
- **Preferential Business Rates:** these are business rate exemptions granted for CHP installation.
- **Carbon Reduction Commitment (CRC):** this is also known as the CRC scheme or CRC energy efficiency scheme. It is a compulsory carbon emissions reporting and pricing scheme that applies to large UK organisations (public and private sector), that have **annual electricity energy consumption** greater than 6,000MWh and possess at least one half-hourly meter settled on the half-hourly electricity market (Carbon Trust, 2018). Participating organisations are required to buy allowances for every tonne of carbon emission associated with electricity and gas consumption, implying that organisations that are able to reduce their emissions can lower their CRC cost (Carbon Trust, 2018). However, the UK government has currently revealed that the CRC will be terminated after the 2018-2019 compliance year, with a possible increase in the CCL to compensate for it (Clean Energy News, 2016 and Carbon Trust, 2018).

2.6.5 UK Grid Decarbonisation and Air quality

The Department for Business, Energy and Industrial Strategy (BEIS, 2018a), published an update to the 2017 Energy and Emissions Projections (EEP) for the UK in January 2018. The report indicates projections of the UK’s performance against the GHG emissions goal under current

policies (i.e. both implemented and planned) and review the legally binding carbon budgets that are fixed for five-year periods; geared at reducing the UK's emissions by a minimum of 80% by the 2050 (Ground Source Heat Pump Association (GSHP), 2018; BEIS, 2018a). The report which presents projections of the UK energy demand and GHG emissions up to 2035, is produced to support the UK government's Clean Growth Strategy (BEIS, 2018a).

The recent UK Clean Growth Strategy, which presents ambitious policy blueprints aimed at ensuring the country attains its carbon reduction targets while grabbing the opportunities of clean growth, also highlighted that the UK is one of the most successful countries in the advanced world to continuously record economic growth and concurrent reduction in GHG emissions (BEIS 2017b). Furthermore, BEIS (2017b) and the recently published Clean Air Strategy report by The Department for Environment Food and Rural Affairs (DEFRA, 2018) have acknowledged the need for continuous significant reduction in CO₂ emissions to curb climate change, along with the necessity for cleaner air, especially as air pollution and poor air quality is a top environmental risk to human health in the UK and the fourth greatest threat to public health (DEFRA, 2018). Moreover, it is essential to curb emissions resulting from heating of dwellings and business, as they account for approximately a third of UK emissions, hence curbing emissions in these sectors can be advantageous in reduced utility bills and improved air quality (BEIS 2017b).

Therefore, CHP technologies along with other low carbon heat and renewable heat sources have helped in the decarbonisation of heating and improving air quality as they displaced energy derived from the highest carbon factor fuels. Although CHP systems provide global environmental merits by displacing electricity generated at remote power stations, the local emissions (such as Nitrogen oxides [NO_x]) that can potentially have an adverse effect on the local environment is a constraint that need to be properly evaluated and controlled. According to CIBE (2013b), the impact of CHP

on the air quality of the local environment can majorly be mitigated by ensuring good and effective dispersion of the combustion gases away from ‘sensitive receptors’ (that is, people that might be affected). This can be accomplished by employing an appropriately high stack to guarantee dispersion by the air in a manner that concentrations at ground level are minimised, whilst also ensuring that due consideration is taken when there are tall buildings around (CIBSE 2013b). Furthermore, DEFRA (2018) have also acknowledged the need to curb air pollution from the recent rise in the use of wood burning stoves, open fires and other sources that make considerable contribution to particulate matter/emissions. Therefore, since the range of fuels for CHP is expanding, particulate emissions need to be considered when utilising biomass or any other liquid fuels, although CHP powered by natural gas or clean synthesis gas from advanced gasification do not pose particulate emission concerns (CIBSE, 2013b).

The Clean Growth Strategy (BEIS 2017b) has acknowledged the enhancement of low carbon heat sources amongst other measures as short to medium term measures of heat decarbonisation. However, as evidenced by the recent BEIS (2018a) EEP for the UK, renewable wind and solar electricity generation capacities have considerably increased while coal-fired generation is being withdrawn. Figure 2.4 shows the electricity generation trajectory from different technologies as set-out in (BEIS 2018a).

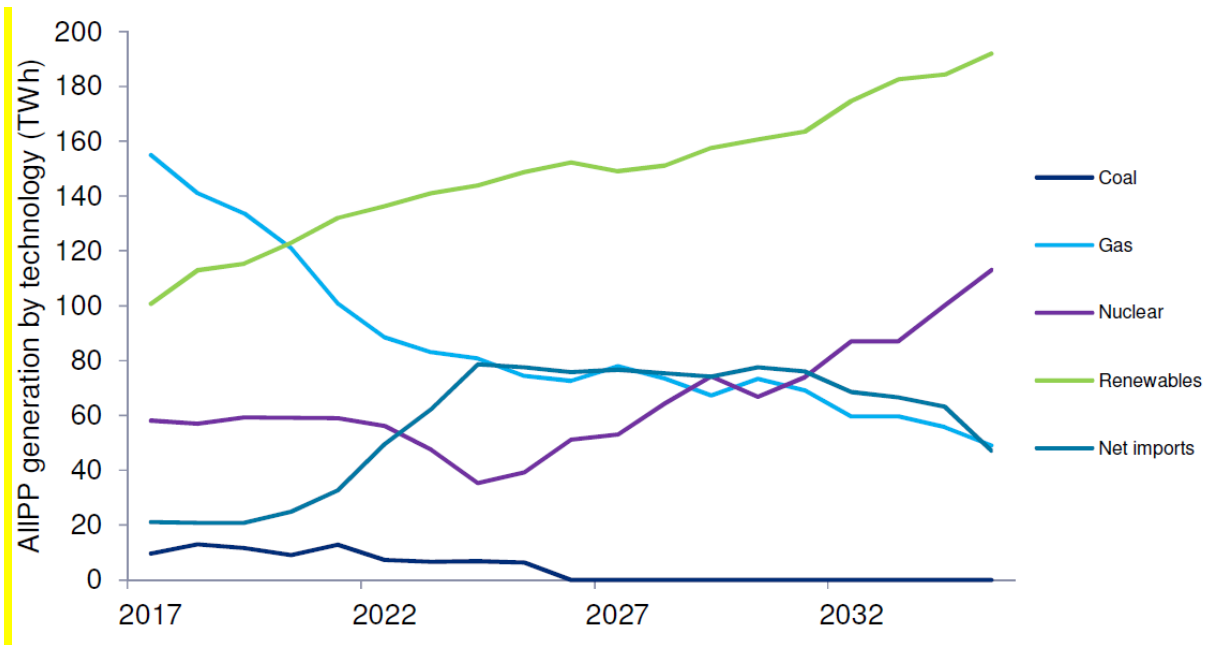

Figure 2.4 UK Electricity generation trajectory by technology (BEIS 2018a)

The increase in renewables electricity generation points to the ongoing decarbonisation of the grid, which can make the environmental benefits of natural gas or other fossil fuels powered CHP less obvious when compared to the potential future grid projections. Although achieving a carbon neutral electricity grid is still far way, however, the BEIS projections indicates that congruence between the power grid and natural gas is being attained around 2020 and could be even better as shown in the grid emissions intensity data and graph presented in BEIS report (GSHP, 2018; BEIS 2018a). Table 2.6 and figure 2.5 show the grid emissions intensity data and graph respectively, reproduced from BEIS (2018a).

Table 2.6: UK Grid emissions intensity data set

Year	EEP 2017	EEP 2016
	(gCO₂e/kWh)	(gCO₂e/kWh)
2017	213.4	264.6
2018	205	235
2019	194.7	223.8
2020	180.9	198.2
2021	170.9	194
2022	147.8	161.3
2023	144.3	170.9
2024	150.1	184.2
2025	140.8	174.3
2026	114.2	153
2027	119.4	143
2028	108.4	118.2
2029	96.1	102.8
2030	104.2	107.1
2031	95.5	100.3
2032	77.7	83
2033	74.5	79.1
2034	66.5	68.9
2035	55	55.3

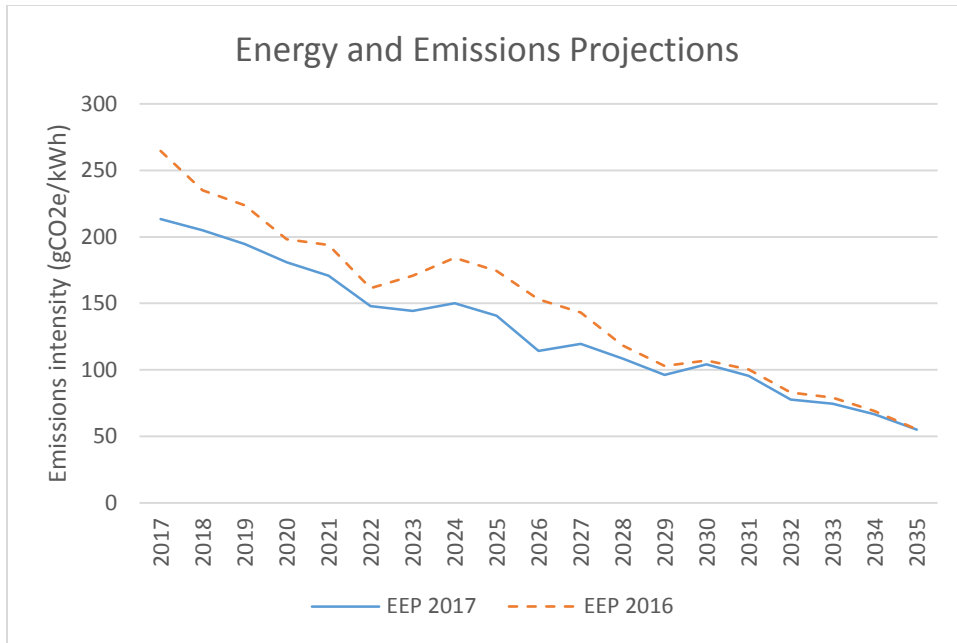

Figure 2.5: UK Grid emissions intensity (BEIS, 2018a)

2.6.6 Studies on performance and application of CHP Systems in efficient energy production

Evaluation of the available literature indicates that numerous researchers have carried out studies on performance and application of CHP systems in efficient energy production and application of CHP in different types of buildings, some of which are presented in this section.

Çakir *et al.* (2012), Mago and Smith (2012) and Barbieri *et al.* (2012) evaluated the potential energy efficiency and emission benefits of CHP systems in different types of buildings. Barbieri *et al.* (2012) evaluated the viability of different micro-CHP systems to satisfy the energy requirements of a typical single-family dwelling. Two varied residential buildings, whose characteristics were in conformity with a typical European single-family dwelling, were used as a case study. Furthermore, the study considered micro-CHP systems based on a variety of existing commercially available prime-movers and individual systems consisting of a prime mover, thermal

energy storage and a back-up boiler to accommodate periods of peak thermal demands. Their outcome indicated that the evaluated CHP systems results in a primary energy saving which is always greater than 20% whilst typically satisfying most of the thermal and electric energy requirements of the dwelling. Moreover, their result highlighted that appropriate sizing of the thermal energy storage capacity is important for beneficial energy performance of the system and that various government incentives are needed to make the application of micro-CHP in residential buildings economically attractive. Comparably, Mago and Smith (2012) worked on evaluating the energy performance of CHP systems in different types of commercial buildings in the United States; however, the study focused on the emission reduction benefits of the considered CHP system. The key findings of their study indicated that CHP use in the evaluated buildings always produced reduced GHG emissions of up to 21% carbon equivalent especially in commercial buildings with high thermal energy demand such as hospitals. They also found that it is usually beneficial to ensure that the CHP system is responsible for a high proportion of the building's thermal demand as this will provide improved primary energy savings, emission reduction and cost savings. Additionally, it is equally important that the thermal capacity of the chosen CHP system be close to the thermal energy requirement of the building to ensure higher efficiency of the CHP system. Çakir *et al.* (2012) examined the contribution of CHP in the sustainability of energy using a case study gas powered prime mover applied to a hospital building. Their study highlighted the concept of sustainability as it relates to CHP and provided a substantial review of studies that present the sustainability perspective of CHP systems even though they generally operate on fossil fuel. The sustainable aspect of cogeneration is associated with their energy efficiency, and there is the possibility of incorporating some renewable energy conversion systems such as solar systems or heat pumps. Their results indicated that the cogeneration system improved

energy efficiency, thereby resulting in energy cost savings, a reduction in GHG emissions and an increase in the reliability of power and reduced grid congestion.

Moreover, in the UK, some studies and reports by trade associations and Government departments such as those of the Association of Decentralised Energy (ADE) and Department for Business, Energy and Industrial Strategy have presented several case studies of different live CHP application. For instance, BEIS (2017c) and BEIS (2017d) presented case studies of large scale CHP installations, certified as 'Good Quality' CHP under the CHPQA programme. Both studies presented installations contributing to district energy provision in the commercial building sector. BEIS (2017c) evaluated the installation of a 4MWe CHP in the main campus of the University of Liverpool to feed into the existing district heating as part of a campus expansion project in 2014. The study demonstrated that the CHP installation is projected to provide considerable environmental and financial benefits as the scheme is expected to provide life time cost savings of £22.6million with in a four year payback period and up to 5,730 tonnes in annual CO₂ emissions savings. In a comparable case study, BEIS (2017d) evaluated the installation of a bigger 7.7MWe CHP capacity providing low carbon heating to several commercial and City council buildings within the Coventry City Centre. The installation provides the low carbon heating from household waste, which is an efficient renewable fuel source compared to conventional fossil fuel energy sources. The study indicated that the CHP delivers several benefits, especially as it provides a carbon saving of approximately 89% relative to traditional stand-alone gas-powered system. In contrast to the aforementioned studies, ADE (2018a); ADE (2018b) and ADE (2018c) presented studies evaluating the installation of small-scale packaged CHP systems in several hotel buildings in the UK. The CHP installations were financed through equipment supplier financing which is a commonly adopted approach to finance small, packaged CHP systems. ADE (2018a) and ADE

(2018b) evaluated the installation of 330kWe and 206kWe CHP capacity to provide space heating, DHW and electricity to Radisson London Stansted Airport hotel and Radisson Edwardian hotel in Manchester respectively. The studies highlighted the suitability of the hotels for CHP installation due to their constant and high demand for space heating and DHW on a 24 hours weekly basis, especially for the case of the Radisson London Stansted Airport hotel which is a modern 500-bedroom hotel with extensive conference rooms, restaurant and health club facilities. Similarly, ADE (2018c) presented the installation of 122kWe and 225kWe CHP systems to provide lower cost energy to The Imperial London Hotels; At the Group's Royal National, Tavistock, Imperial and President Hotels, that provide nearly 3,000 guest rooms for visitors to the Capital and are in close proximity to one another. The case studies of ADE, (2018a); ADE (2018b) and ADE (2018c) all demonstrated that the CHP installations in the different hotel buildings provide several benefits, especially considerable financial savings compared to the traditional energy supply, exemption from the government's climate change levy along with improved energy efficiency offering reduction in GHG emissions.

In consonant with other research on the application of CHP in the UK, some studies such as those of Nock *et al.* (2012); Kelly *et al.* (2014); Amber *et al.* (2018) and Salem *et al.* (2018) presented and assessed the application of CHP in different sectors of the UK. The work of Nock *et al.* (2012) evaluated the prospects of CHP usage UK wide, while also providing a simple model for evaluating CHP feasibility. The outcome of their work established from the case studies demonstrated that CHP has the potential to deliver considerable environmental and financial benefits. Furthermore, the simple model proposed by the studies gives good results when compared against alternative CHP feasibility and sizing models, which are usually complex and require large input data that are generally unavailable. On the other hand, Kelly *et al.* (2014) investigated the suitability of

industrial application of CHP technology as a low carbon alternative for electricity generation in the UK, through a life cycle assessment of an operational industrial CHP plant as case study. One of their key findings indicated that substantial savings on environmental impact are obtainable in comparison to the 1990 baseline National grids, as the industrial CHP has the possibility to provide electricity at a 77% carbon savings per MWh over the 1990 baseline national grid. Moreover, their study investigated the impact of grid decarbonisation in the UK and opined that the carbon emission benefits of such industrial CHP application in the UK can become less noticeable when compared to potential UK future grids. In a similar study, Salem *et al.* (2018) evaluated the possible carbon emissions and financial impact of CHP and Combined Cooling and heating and Power (CCHP) application in commercial buildings, via dynamic simulation and payback financial analysis of an existing UK hotel building as case study. Their results indicated that the application of CHP and CCHP can deliver up to 32% and 36% reduction in carbon emissions respectively in current climate, with the CHP presenting better financial savings and shorter return periods. Moreover, their study assessed the performance of the systems under future UK climate projections and demonstrated that CCHP systems presents better performance over a CHP system, due to the projected warming of future UK climate. However, their study did not consider the impact of current and future UK grid decarbonisation. Amber *et al.* (2018), assessed the application of a CHP system in a UK University student residence, with focus on the factors that influences the economic and environmental feasibility of CHP application. One of their main findings indicated that the advantages of CHP is largely linked to appropriate CHP sizing and demonstrated that the price of grid supplied electricity is a key factor that can impact of the financial viability of CHP application.

Table 2.7: Summary table of previous studies on performance and application of CHP Systems in efficient energy production

Source	Area of study/ concern addressed	Location/Climate
Çakir <i>et al.</i> (2012)	Energy efficiency and emission benefits of CHP systems	Erzurum, Turkey [Temperate Humid Continental]
Mago and Smith (2012)		USA [Cold, heat-dominant climatic zone of the USA]
Barbieri <i>et al.</i> (2012)		EU [Sub-tropical climate]
BEIS (2017c); BEIS (2017d); ADE (2018a); ADE (2018b) and ADE (2018c)	UK case studies on live CHP application	UK
Nock <i>et al.</i> (2012); Kelly <i>et al.</i> (2014); Amber <i>et al.</i> (2018) and Salem <i>et al.</i> (2018)	Application of CHP in different sectors of the UK.	UK

Chapter 3: Methodology

3.1 Research Paradigm

The research methodology that is employed in this work is quantitative. This research project conforms with quantitative research as this work, which aims at analysing and examining the efficiency of UK hotel buildings, uses data that are measured and expressed numerically, for example, dimensions, temperature, time and percentages. This data collection type is associated with the quantitative method, which contrasts with most qualitative methods. Punch (2005) and Saunders *et al.* (2016) opine that quantitative research generally utilises numerical data and characteristically has a defined or rigid structure, predefined research questions, predefined objectives and method. Similarly, Creswell (2014) presented some characteristics of quantitative research as having closed ended questions, a predetermined method, employing standards of validity and observing data numerically. On the other hand, Leedy and Ormrod (2015) point out that qualitative research commonly involves investigating the characteristics or properties of a particular phenomenon that cannot be completely reduced to numerical or empirical values. Additionally, this research method is usually employed in studies of complex human conditions (such as the evaluation of the in-depth perspective of people about a specific matter or the behaviours and ideals of a particular cultural group), which is not the case for this research project. The argument for a quantitative research method as against the qualitative is that it allows for testing of hypothesis and provides the possibility of generalisation or replication of the research results as it is aligned to an objectivist viewpoint (Allwood, 2012; Creswell, 2014). Therefore, the quantitative research approach is employed in this work for data collection and analysis. The methodology used in this research is underpinned by dynamic building simulation and modelling and was established by the use of several case studies aimed at evaluating the impact of various

energy saving and improvement technologies on the thermal behaviour, energy performance and CO₂ emissions of existing hotel buildings in the UK.

3.2 Research Design

There are several forms of research design that are suitable for different research types and the choice of an appropriate research design type hinges on the nature of problems posed by the research aim and the method of data collection and analysis (Nicholas, 2010). Some of the common research designs, according to Nicholas (2010), include: historical, correlation, descriptive, experimental, comparative, simulation, evaluative, action and ethnological. The research design of this work conforms more with simulation and evaluation. For Nicholas (2010), simulation entails developing a representation of a system in a simplified form (model) that can be manipulated or used to measure effects. It is similar to experimental design in terms of its characteristics of manipulation, but it differs as it provides an environment that does work with original materials at a similar scale. Furthermore, simulation enables hypothetical scenarios to be examined and hence, the performance of the models should be validated or attuned against the actual system to ensure reliability of results.

The research design of this work is based on the investigation of the energy performance and efficiency of UK hotels by in-depth simulation and analysis of the impact and interdependency of various energy saving technologies used to reduce energy consumption and improve energy efficiency in hotel buildings. Moreover, it examines how building energy parameters of occupants' behaviour, energy consumption and building fabric can be modelled correctly in order to improve building energy efficiency and reduce carbon emissions of existing UK hotel buildings.

Necessary primary data such as building architectural plans, elevations, type of HVAC, building fabric and energy consumptions of the selected hotels were collected to create holistic models. The models were simulated using a dynamic thermal analysis simulation software to obtain its current energy performance. The software that was employed in this research was EDSL Thermal Analysis Software (EDSL 2015a), which is a robust 3D modelling and whole building simulation software. The energy consumption results obtained from the simulation were validated using the data of the actual consumption for the various hotels. Subsequently, the validated holistic models were used to investigate and test the impact of various technologies and interventions that were geared towards reducing energy consumption on the energy performance of the hotels. The energy saving technologies considered were mostly suggested by the hotel management while some were suggested by the researcher. Importantly, the model was made to be flexible to allow for testing the interdependency of these various technologies installed either individually or in combination and also their likely impact on HVAC, lighting, domestic hot water and catering services within the property.

3.3 Ethical Considerations

As evidenced by the adopted research method, this research work did not involve human participants for data collection such as interviews or questionnaires. Therefore, the research was not at risk of violating ethical considerations such as informed consent of participants, invasion of a participant's privacy or deception. However, adequate honesty in the research data collection, interpretation and analysis was ensured by sharing the results with other researchers via publications; plagiarism is avoided by providing adequate citation. As required by law, all data obtained and used for this research is protected in line with the Data Protection Act 1998, which

requires that data are used lawfully for the specifically stated purpose, relevantly used without excesses, kept safe and secure and not transferred without permission.

3.4 Building simulation methodology

The goal of this thesis is to evaluate the energy consumption and the impact of selected energy improvement measures on the energy performance of three case study Hilton hotel buildings located in the UK. The evaluation is conducted with the aid of an approved dynamic simulation software and the case study hotels are Hilton London Heathrow Airport Terminal 4, Hilton Reading and Hilton London Gatwick Airport. The main simulations to be undertaken are:

- **Estimation and validation of the energy consumption of the case study hotel buildings using the dynamic simulation software:** These simulations are expected to produce base models with relatively similar performance to the case study buildings, which are subsequently used to evaluate the selected energy improvement measures.
- **Evaluation of the impact of extraction fans in the cavity of the East and West DSF on the thermal and energy Performance of Hilton London Heathrow Airport Terminal 4:** The DSFs are adjoining a large central atrium which is a central social hub in the building housing the reception, bar and restaurant. The study was undertaken due to the existing challenge of high temperature observed in the DSF cavity, thus having an adverse effect on the temperature of the large central atrium, increasing cooling demand and affecting guest comfort. The simulation evaluating the installation of extraction fans as a DSF cavity ventilation strategy is expected to improve the internal thermal environment of the atrium space and serve as an alternative measure to increasing the capacity of the chillers, which can have an unfavourable impact on the total energy consumption of the hotel.

- **Evaluation of the impact of window films on the energy performance of existing UK hotel buildings:** This simulation which was undertaken using two different hotel buildings with different building façades is aimed at evaluating the impact of several commercially available window films on the overall energy performance of existing UK hotel buildings. The first and main case study is the Hilton Reading hotel which is a typical single-skin glazed wall structure with relatively high window to wall ratio. whereas, the second case study for this simulation is the Hilton London Heathrow Airport Terminal 4 which is primarily a conventional framed structure building with cavity waling and double-glazed windows. This simulation was expected to help reduce the cooling requirement of Hilton Reading hotel, reduce solar heat gain and glare especially in the large restaurant and bar area.
- **Evaluation of the impact of CHP systems on the energy performance of existing UK hotel buildings and optimum size selection in CHP retrofitting:** This simulation was undertaken to evaluate the environmental and financial benefits of CHP retrofitting on a case study large hotel building (Hilton London Gatwick Airport) and also inform the optimum size selection. The outcome of the simulation is expected to demonstrate the appropriateness of CHP as an energy efficient technology for provision of heating and electricity especially in large hotel buildings, consequently, delivering considerable utility cost savings and environmental benefits.

The main reasons that informed the choice of the selected fabric improvement measures and technologies studied in this thesis include: the areas identified from literature requiring further research and availability of data for existing hotel buildings. Moreover, availability of data for existing hotel buildings was the main influencing factor, as it has been highlighted in the

background section 1.1, that hotels are less studied sectors in comparison to others mainly due to limited availability of data. Additionally, as the hotel sector generally prioritise luxury and guest comfort, the management of the partnering hotels were keener on measures that can address their prevailing challenges with guest comfort, while also providing energy performance improvement. Therefore, to facilitate access to data from the different hotel buildings, selected measures and technologies were chosen together with the hotel management to address their immediate challenges and evaluate energy improvement measures of common interest for the buildings with available data.

The process that was employed to achieve the articulated aim with the case study buildings can be categorised into two distinct stages. The first stage involves estimating the energy consumption of the buildings by developing holistic models reflecting the building fabric, systems and thermal performance of the actual buildings. The predicted energy consumption is validated by comparing against actual consumption data. These data are collected by survey and visitation of the case study buildings to enable verification of available data such as building fabric data (e.g. walls and windows), occupancy information to ensure simulation assumptions are realistic, building usage to ensure zone grouping is as shown on architectural plan and HVAC system characteristics. Whereas, the second stage entails the introduction of the selected energy and thermal improvement measures into the models to evaluate their impact. That is, installation of window films to the Hilton Reading hotel; installation of ventilation fans to the east and west double skin façade of the Hilton London Heathrow Airport Terminal 4 and evaluation of CHP retrofitting in the Hilton London Gatwick Airport.

Generally, the different case studies presented in this work are made up of several models categorised under two simulation stages. Table 3.1 presents general description of input used in the models.

Table 3.1: General description of input used in the models

	First stage of simulation	
Model	Brief description	Unregulated energy use
System/plant model	Energy model simulated via system modelling component of software using customised TBD file. The TBD file uses editable internal conditions and building fabric data that reflect operational building parameters (such as occupancy hours and temperature set-point).	Catering energy use not considered
System model + Catering	Energy model simulated via system modelling component of software using customised TBD. The result is modified by accounting for unregulated catering energy use.	Catering energy use accounted for using benchmark.
	Second stage of simulation	

System/plant model	Energy model is simulated via system modelling as done in the first stage. However, the TBD file used incorporates the energy improvement measures to be evaluated (such as window film and change in ventilation rate due to extract fan introduction)	Catering energy use not considered
System model + Catering	Energy model is simulated via system modelling as done in the first stage. However, the TBD file used incorporates the energy improvement measures to be evaluated and the result is modified by accounting for unregulated catering energy use.	Catering energy use accounted for using benchmark.

3.4.1 CIBSE TM 54 Methodology

Preceding section 2.3 of this thesis has highlighted the challenges of building simulation modelling, particularly the difference between predicted building performance and actual building performance, termed as the ‘performance gap’. In late 2013 CIBSE published the CIBSE TM 54 which is an industry recognised technical memorandum developed to address the increasing awareness of the discrepancies between the energy performance of operational buildings and the

energy predictions at the design stage (Carbon Bites, 2016). According to CIBSE (2013a), the two primary factors precipitating building performance gap include: firstly, the energy estimation method for compliance modelling which does not account for unregulated energy consumption (such as lifts, escalators catering facilities and server rooms) and they can be substantial. Secondly, the site practices and occupiers' behaviour in operational buildings are dynamic and onerous to replicate, especially buildings need to be built, operated, used and maintained in consonant with the intended design to deliver the predicted performance. CIBSE TM 54 mainly focuses on the first factor related to the method building compliance models, by providing building designers and clients with definite guidance on an approach to estimate the energy use of buildings with relative accuracy at the design stage (CIBSE, 2013a). Moreover, the developing building models following the TM54 framework, often involves modification of the Part L/EPC model using the same dynamic simulation software (CIBSE, 2015b). CIBSE (2013a) and Carbon sites (2016) delineated the aims of the TM54 methodology to include:

- Assisting engineers effectively handle a project brief where an operational energy goal has been fixed.
- Provision of a methodology that engineers can employ to carry out better-informed calculations of operational energy use.
- Demonstrate that energy performance is reliant on on how the building is operated and maintained, along with how it is designed and constructed.

The methodology which is mainly targeted at UK Engineers and consultants, focuses on non-domestic buildings as it used a worked example for an office building to demonstrate the application of the method (CIBSE 2013a). However, it can also be adapted to other countries, with suitable modifications to the benchmarks and references (CIBSE 2013a). Figure 3.1 shows the

summary of the TM54 methodology for estimating the operational energy consumption at the design stage.

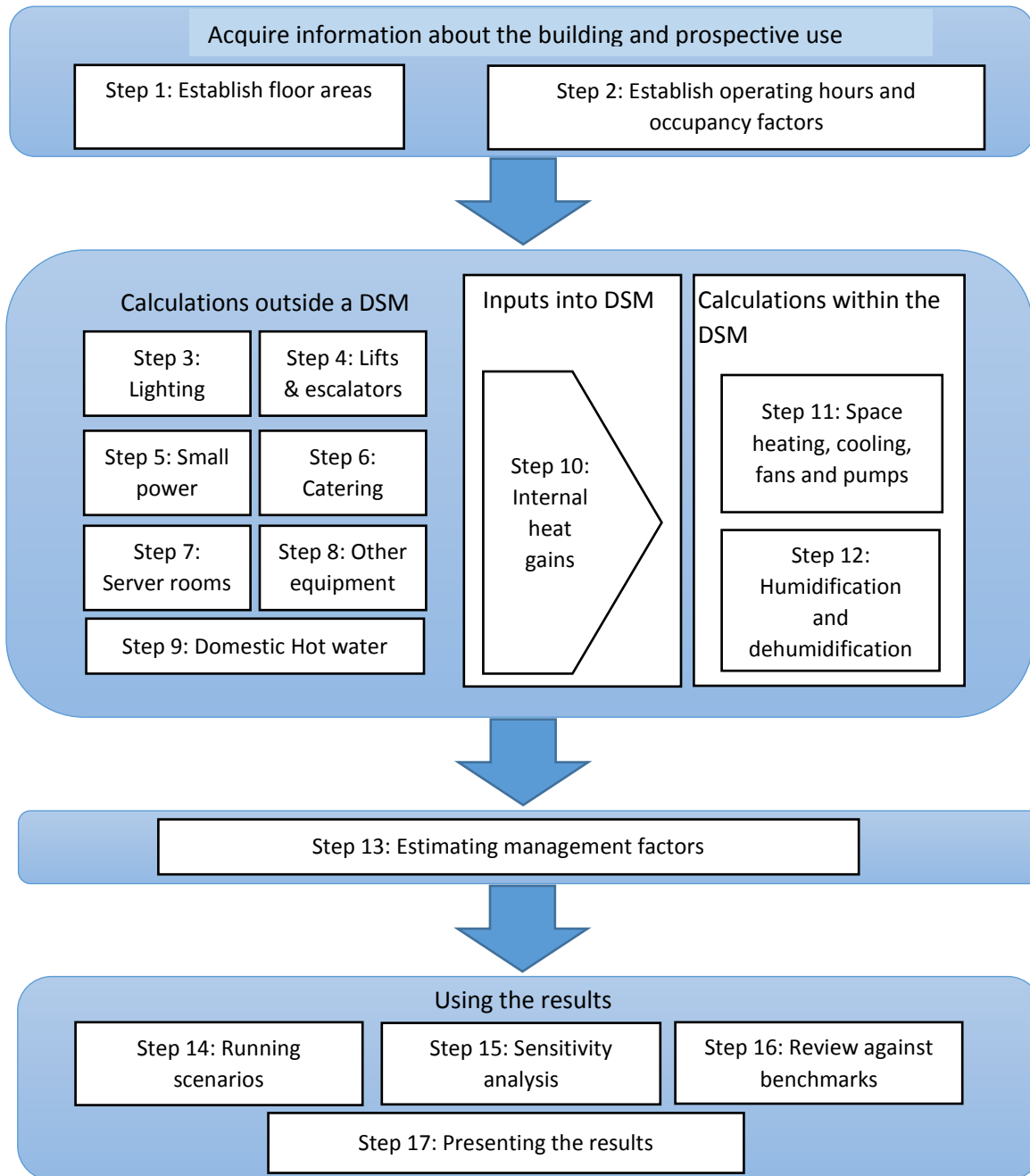

Figure 3.1: Summary of the TM54 methodology for estimating the operational energy consumption at the design stage (CIBSE 2013a).

The TM54 methodology being a recognised methodology in the UK building sector for improving the energy prediction of building energy models informed the methodology used in this thesis. Although, TM54 presents a methodology to help engineers to produce informed energy performance prediction at the design stage, the methodology also provides a framework that can be adopted to evaluate energy use in existing buildings during refurbishments and building upgrades (Bhaumik, 2014). Therefore, similar steps to that of TM54 were adopted in the building simulation methodology of this thesis for the hotel buildings. Largely, similar steps to that of steps 1 to 12 of TM54 was followed in the building simulation methodology for this thesis. For instance, steps 1 and 2 of TM54 informed the adoption of site visitation of the hotels to verify the data provided such as, verification of the floor areas, building usage and establishment of information on occupancy level and pattern. Additionally, unregulated energy use like catering energy use was estimated outside the DSM, several calculations, such as space heating, cooling, fans, pumps, humidification and dehumidification were undertaken within the DSM as recommended by steps 11 and 12 of TM54 methodology. However, the building simulation approach for this thesis differs from that of the TM54 because the calculations outside the DSM was limited, as the methodology of this thesis was aimed at using the limited available data provided by the hotels. Hence, this study method generally made modifications to the input data (such as lighting, DHW, and internal conditions) of the DSM using appropriate benchmarks applicable to hotel buildings. Besides, some of the calculations for energy end use, such as server rooms, small power and other equipment are not considerable in hotels, compared to large office buildings used to demonstrate the application of TM54. While catering energy use which is substantial in hotel buildings with restaurants was calculated outside the DSM using suitable benchmarks for commercial kitchen energy use as recommended in TM54.

3.5 Selection of Simulation Tool

The challenge of improving the energy efficiency of new building design and retrofit of existing buildings requires that energy efficient measures and strategies need to be examined and validated with the aid of simulation tools. Therefore, professionals in the built environment often resort to the use of several simulation approaches. Some of the approaches are generally underpinned by the thermal information and physical equations of the building while others are based on data collected inside the building (Fumo, 2014). The first approach, which is based on thermal behaviour modelling, is the physical model, also referred to as ‘white box’, and the second approach is based on statistical or machine learning formulation and it is also referred to as the ‘black box approach’ (Foucquier *et al.*, 2013). According to Zhao and Magoulès (2012), Engineering methods of building energy estimation are also based on the physical principles and numerous software tools for building energy efficiency evaluation (such as Energyplus, BLAST, ESP-r, DOE-2) are underpinned by the white box approach.

Physical models employ the solving equations representing the physical behaviour of heat to model the thermal performance of various building types with their distinct parameters; that is, their inputs are known, and the aim is to predict the output (Fumo, 2014; Amara *et al.*, 2015). The white box models allow for the evaluation of the internal thermal environment in a building for different period and spatial scales, that is yearly, monthly, daily and hourly or the entire building, a room or a cell of a room (Foucquier *et al.*, 2013). The equations are solved with the aid of numerous available numerical simulation software, which are all theoretically capable of analysing the mechanism of the heat transfer equations written through the energy conservation law (Foucquier *et al.*, 2013):

$$\Phi_{int} + \Phi_{source} = \Phi_{out} + \Phi_{stock} \quad (1)$$

Where Φ_{int} : is the flux of incoming heat into the system; Φ_{source} : is the flux of heat from an eventual heat source; Φ_{out} : system outgoing heat flux; Φ_{stock} : stored heat flux in the system. The main in and out-going fluxes occurring in the heat transfer system are the conduction via walls, the ventilation and the longwave and shortwave radiation. Examples of currently used physical models include multizone, zonal and CFD methods with the most detailed model being the CFD (Foucquier *et al.*, 2013).

On the other hand, statistical or black box simulation tools majorly use historical data on building energy consumption, which is analysed with a basic or multivariable regression analysis to determine the correlation between the outputs and inputs data such as weather data, behaviour of occupants and the operation parameters (Fumo, 2014). These models are characterized by an input-output behaviour without any detailed data about the structure and therefore this method is most suited when physical knowledge of the building is not available (Amara *et al.*, 2015). Some examples of statistical techniques used in building energy prediction include linear multiple regression, the artificial neural network, the genetic algorithm and the support vector machine (Foucquier *et al.*, 2013). According to Zhao and Magoulès (2012), another simulation modelling tool or approach, referred to as the ‘gray model’, is used especially when the data of the building system is partially known or due to data uncertainty.

The simulation tool selected for this study based on the research aim is a physical model tool which is capable of predicting the thermal behaviour of whole buildings within a reasonable time and consequently, allows for the estimation of key energy performance indicators such as overall energy consumption, mean internal temperature, building cooling or heating demand, cost analysis and interrogation of individual zone mean temperature and environmental emissions. Furthermore, the energy performance results, such as total energy consumption, are validated with measured site

data. This is done to guard against some of the major drawbacks of physical models that are related to the uncertainties in input parameters such as weather data and occupant characteristics or some assumptions made within simulation software to reduce the model complexity.

3.5.1 TAS building simulation software

TAS software version 9.3.3 was employed as the dynamic simulation software to model and calculate the energy performance for this study. The TAS software, designed by Engineering Development Solutions Limited (EDSL), is a set of application products with the capability to simulate thermal performance of buildings and their systems, which can be translated to energy consumption estimates (Crawley *et al.*, 2008). EDSL (2015a), highlighted the fact the software is approved and fully accredited for the UK building regulation 2013 and demonstrates compliance with various BS EN ISO standards. Its aptness as software for building performance estimation and energy use prediction has also been appraised via the Building Energy and Environmental Modelling (BEEM) checklist and it has demonstrated compliance with the American Society of Heating, the Refrigerating and Air Conditioning Engineers (ASHRAE) 140-1 building envelope and the HVAC equipment performance test (EDSL 2015a). The software has a 3D graphic based geometry input interface (3D Modeller) that includes a CAD link and can also perform daylighting calculations (Crawley *et al.*, 2008; EDSL, 2015b). The core module is the TAS Building Designer (TBD), which performs a dynamic building simulation with integrated natural and forced air flow (Crawley *et al.*, 2008). Furthermore, it provides a comprehensive solution as a powerful simulation and 3D modelling tool and realistically accounts for occupied summer hours underpinned by the CIBSE TM52 adaptive overheating criteria (Amoako-Attah and B-Jahromi, 2014). TAS systems is the component of the software suite which provides plant modelling capabilities to simulate systems such as heat ventilation and air conditioning (HVAC) systems/control. Another part of the

TAS software suit is the TAS Ambiens, which is a strong and easy-to-use 2D CFD package capable of producing a cross-section of micro climate variation (Crawley *et al.*, 2008). Although there are numerous kinds of building software available with similar capabilities, TAS software was selected because it is fully accredited in the UK for compliance with building regulations Part L2, building performance estimation and energy use prediction. TAS 3D modelling input interface is also more intuitive relative to some equally powerful and popular simulation software types like EnergyPlus, which has text file input and output interface. Moreover, it has been used commercially in the UK and around the world for over 20 years with a reputation for its robustness, reliability and wide-ranging capabilities. The software was also selected as it was developed in the UK and its developer is domiciled in the UK, which ensures access to better support and training opportunities.

3.6 TAS Building Simulation Principle

The TAS building simulator performs the thermal analysis of the building to evaluate the environmental performance, ventilation analysis, energy use estimation, plant sizing and energy conservation measures. The building simulator uses the building geometry along with comprehensive building data for projected internal gains, rates of ventilation and infiltration, shading features, occupants' characteristics, apertures, heating and cooling set-points and building fabric. EDSL (2015b) presents the approach underpinning dynamic simulation on TAS. Generally, the software analyses the building's thermal condition via a succession of hourly snapshots across the year. This provides a comprehensive depiction of the thermal performance of the building under the inputted design condition. The approach also allows for evaluation of the impacts of the thermal processes happening in the building including their timing, interaction and location. The software's analysis process is based on the heat transfer mechanisms of the building, that is, the

movement of various heat forms as it is transported into, out of and round the building envelope via different heat transfer mechanisms such as conduction, convection, long wave and solar radiation. Figure 3.2 presents a representation of the heat transfer mechanism of a building.

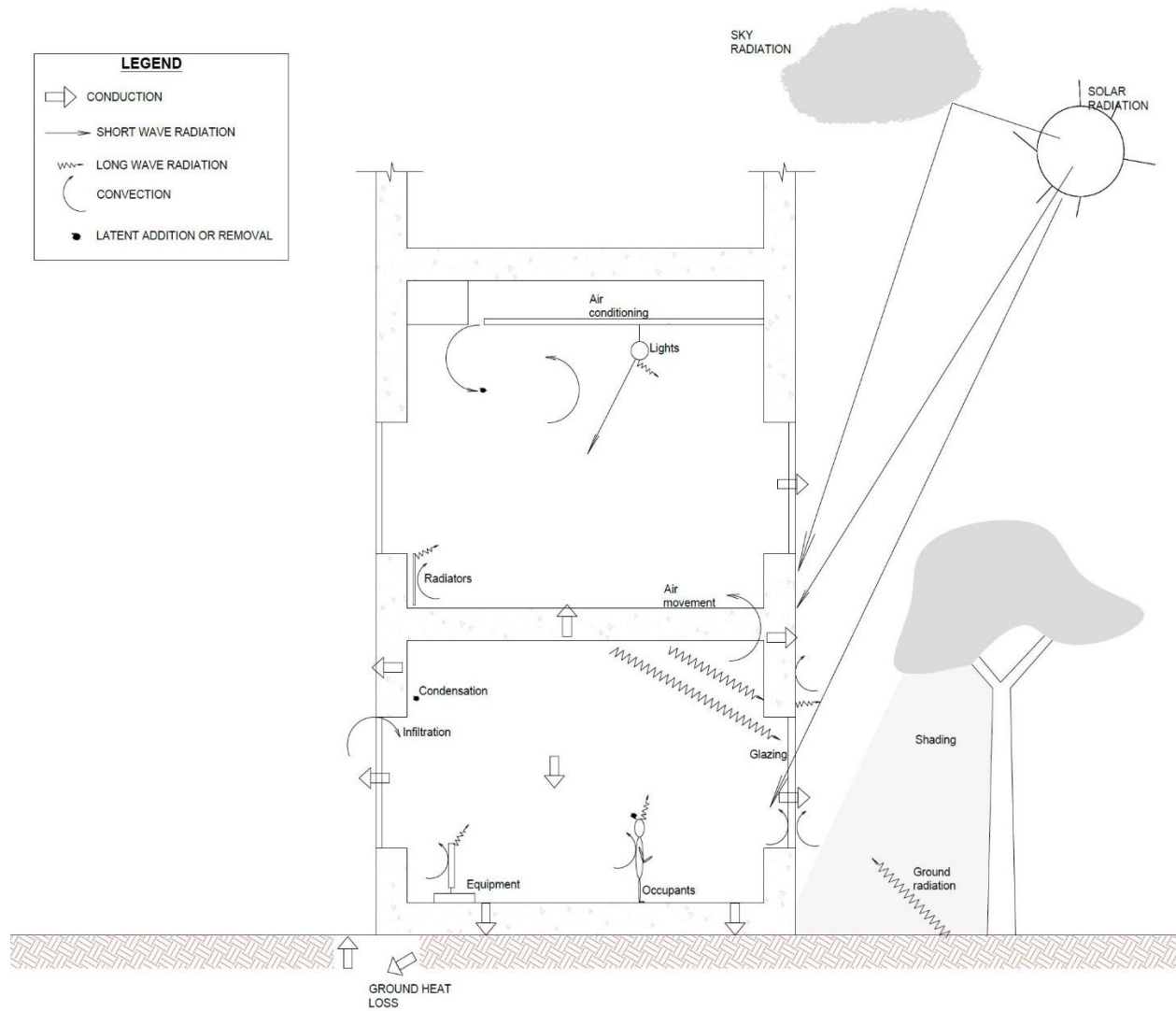

Figure 3.2: Heat transfer mechanisms in a building (reproduced from EDSL, 2015b)

The software method to treat the heat transfer processes in the mechanisms is presented below:

- **Conduction**

The method used for dynamic analysis of conduction in the building fabric is based on the ASHRAE Response Factor technique. This computational method evaluates conduction at building surfaces of building elements (such as walls or floors) as histories at those surfaces. Furthermore, the software allows a building fabric with multiple layers to be analysed and each layer may be made of varied materials including opaque (such as wood), transparent (such as glass) or gas (such as air).

- **Convection**

Convection at building surfaces is computed by applying a combination of theoretical and empirical relationships associating convective heat flows to surface temperature difference and orientation and in the instance of external convection, wind speed.

- **Radiation**

The computation of exchange of long-wave radiation is underpinned by Stefan-Boltzmann's law, which states that the total emitted heat energy from a surface is proportional to the fourth power of its absolute temperature (Encyclopedia Britannica, 2009). The weather data provide all necessary information used to compute the solar radiation absorbed, reflected and transmitted by individual elements of the building. The computation calculates the incident fluxes via information of the position of the sun and empirical models of sky radiation while also resolving the radiation into direct and diffuse components. The software computes the absorption, reflection and transmission from the thermo-physical characteristics of the building. Moreover, incoming solar radiation via transparent building elements is absorbed, reflected or transmitted based on when they fall on internal surfaces. In addition, the distribution of reflected and transmitted solar radiation lasts until all the radiation is accounted for.

The TAS building simulator allows some factors that impact the thermal behaviour of buildings such as thermal insulation, thermal mass, climate, glazing characteristics, building fabric, solar gains and plant schedule. It also provides results indicating the effect of these factors on air temperature, radiant temperature, resultant temperature, humidity, energy consumption, etc.

The processes that were used to develop the holistic building models for energy estimation and evaluation of improvement measures in the dynamic simulation software TAS are presented in sections 3.7-3.10.

3.7 EDSL TAS 3D Modelling Process

The TAS 3D modeler component of the software enabled information on the building geometry and fabric such as floors, wall types, windows and doors dimensions to be inputted. Also, the categorisation of the floor areas into different zones based on their usage was done and all these data were used to generate the 3D model as close to reality as possible. The data used for the 3D modelling was obtained from the AUTOCAD drawings of the hotels, which show plans for individual floors.

The AUTOCAD drawings were also used for obtaining the measurement of doors, windows and default floor height. The original AUTOCAD file was modified by purging and removing unnecessary layers and drawing a 20m reference construction line. Finally, each floor was saved as a separate file.

The drawings also provide the categorisation of the building floors into various zones such as bedrooms, reception, offices, kitchen etc. which were used in various stages of the simulation process. The zoning process was done meticulously based on the usage of the space as it has a

direct bearing on the resultant internal condition of the space. The flowchart presented in Figure 3.3 shows the floor modelling process used for the 3D modelling of various floors of the buildings:

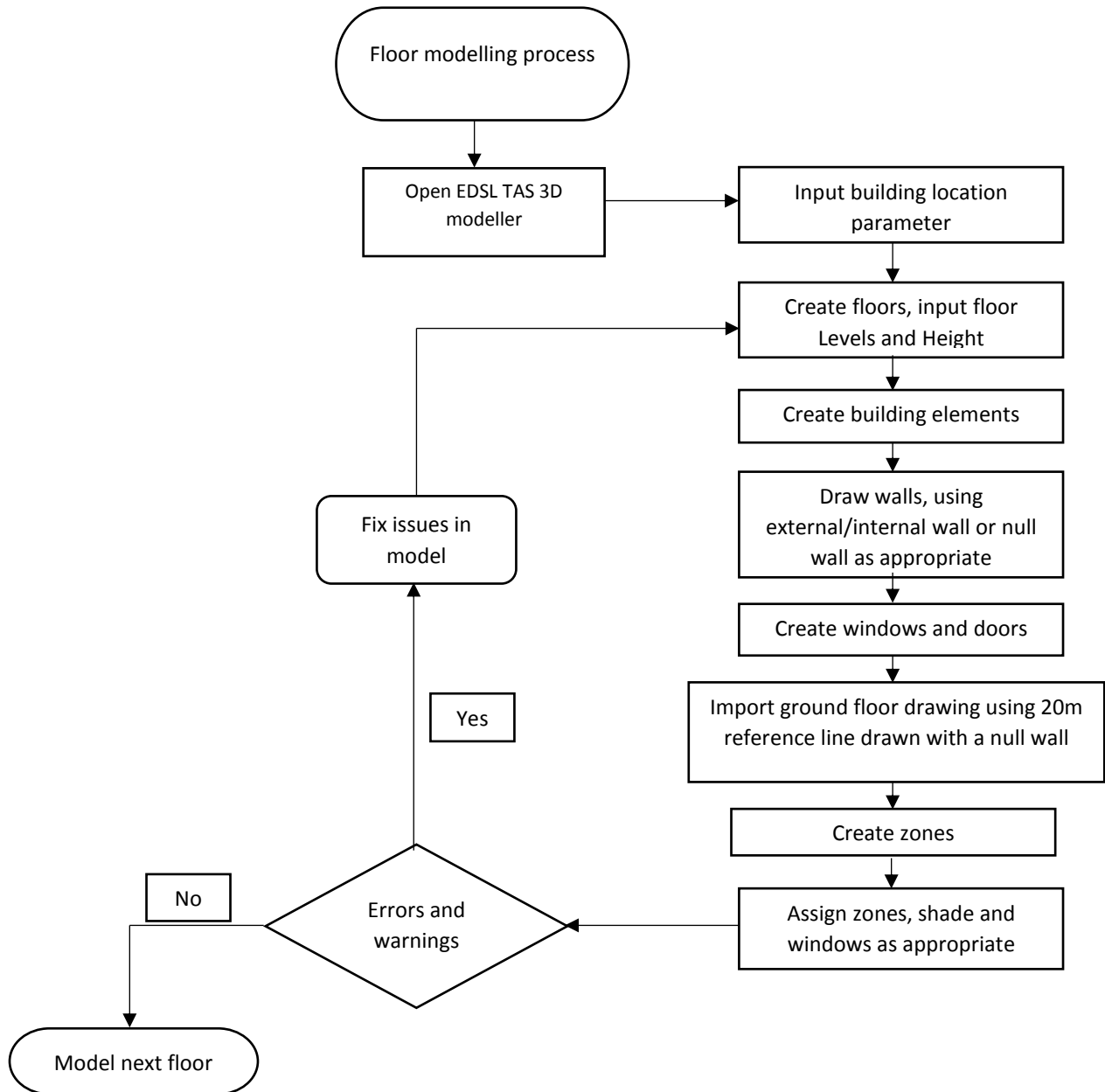

Figure 3.3: Floor modelling process

3.8 Thermal Simulation Process

The TAS TBD component of the software is the core part of the software suite and it performs the thermal simulation of the building. Appropriate choice of modelling parameters and assumptions are needed to carry out building performance simulation. The modelling parameters and assumptions used in this study to execute the building performance simulation are enumerated below:

- A. Appropriateness of CIBSE TRY weather data (which is based on a historic average data pattern over a certain number of years) to be applicable to prevailing weather conditions of the case study building location.
- B. Acceptability of the National Calculation Methodology's standard hotel internal conditions activity and occupancy as existing conditions of the case study hotel building.
- C. Assumption of U-values to be static rather than being dynamic, as they normally vary with thermal and climatic environment.

Figure 3.4 presents a flowchart illustrating the various simulation parameters such as calendar, weather data, internal conditions, zones, etc. that were populated to conduct the thermal simulation on the TAS building simulator:

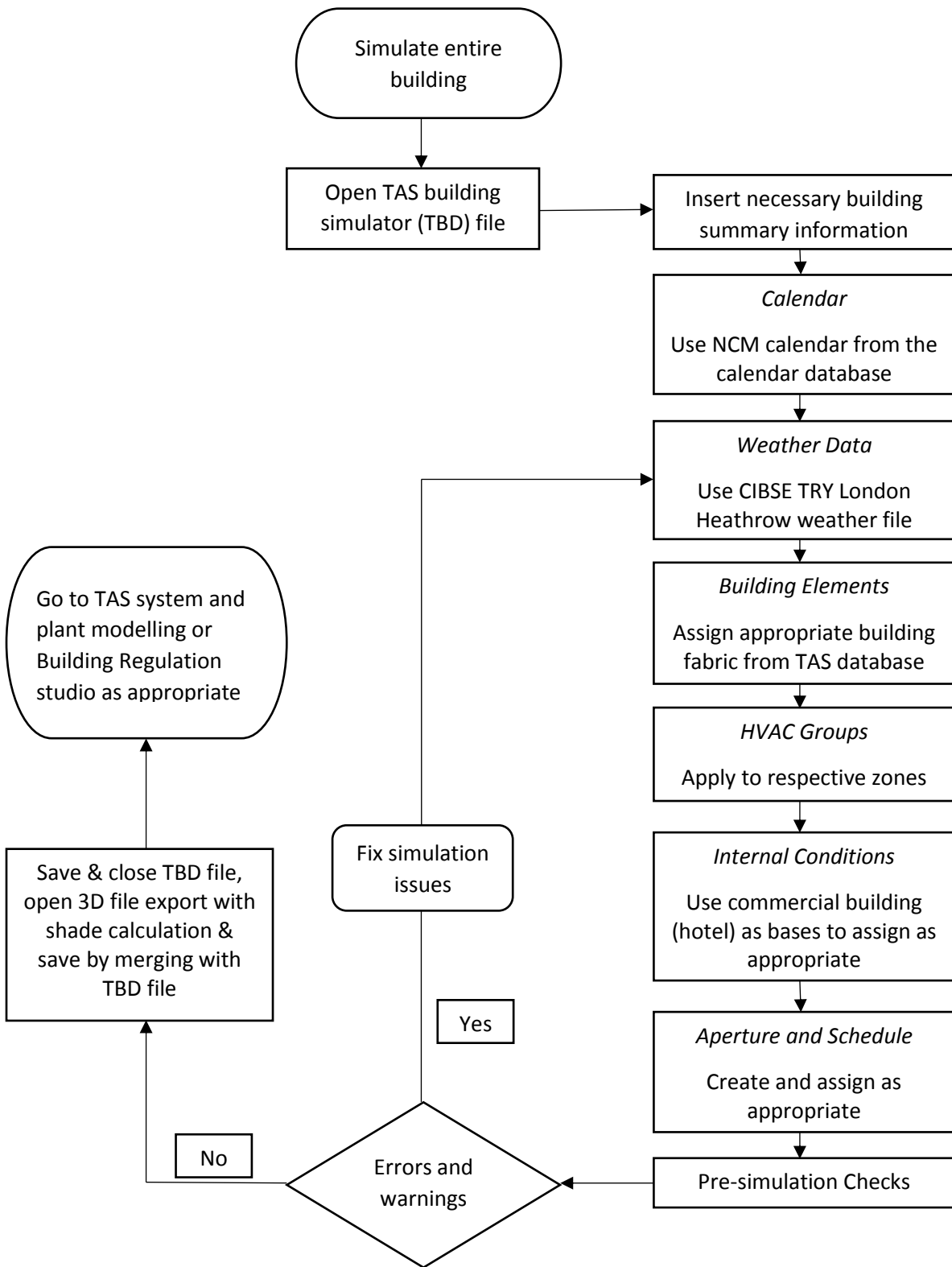

Figure 3.4: Building thermal simulation process

3.9 Plant/systems Modelling

The TAS systems module of the software suite enables the thermal simulation result file, referred to as the TSD file, to be directly coupled to it. The systems module enables the simulation of the building's plants consisting of heating and cooling circuits, air handling units, and energy sources along with the TSD file to produce energy performance results such as total energy consumption and demand. However, the estimate does not account for unregulated energy use such as catering, which can be significant in a hotel building and is therefore estimated in this work to augment the TAS systems result. Figure 3.5 below presents the TAS systems wizard simulation process.:

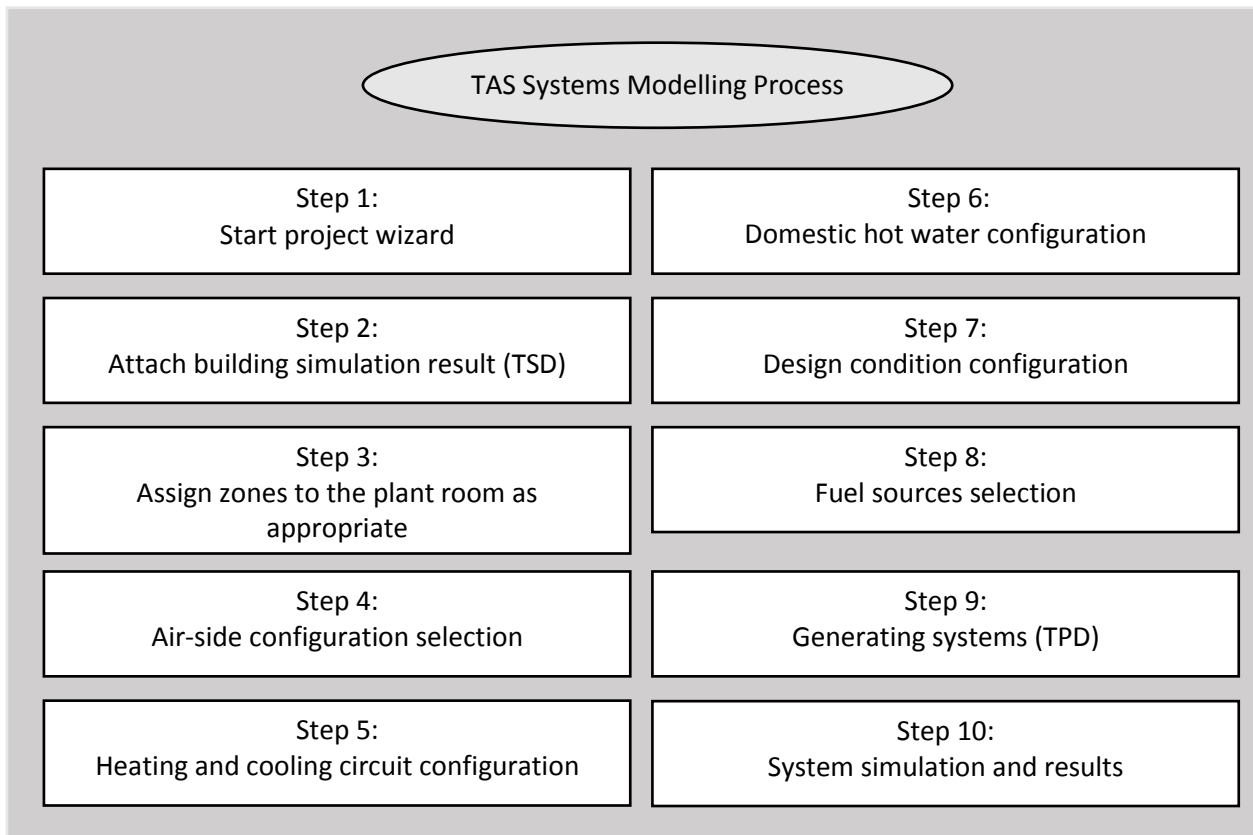

Figure 3.5: TAS systems simulation process

3.10 UK Building Regulation Model

The UK building regulation component of EDSL TAS, which is based on the 2013 building regulations, was also used for this study. It subjected the simulation result to the NCM standards to estimate the energy performance of the building mainly for compliance purposes. The building regulation model was done by systematically going through the regulation studio of the program and selecting appropriate parameters to develop the building’s plant circuit arrangement, which was translated into a generation of various building reports which included Energy Performance Certificate (EPC) documents, total energy consumption, carbon emissions and fuel use. Figure 3.6 shows the UK building regulation process.

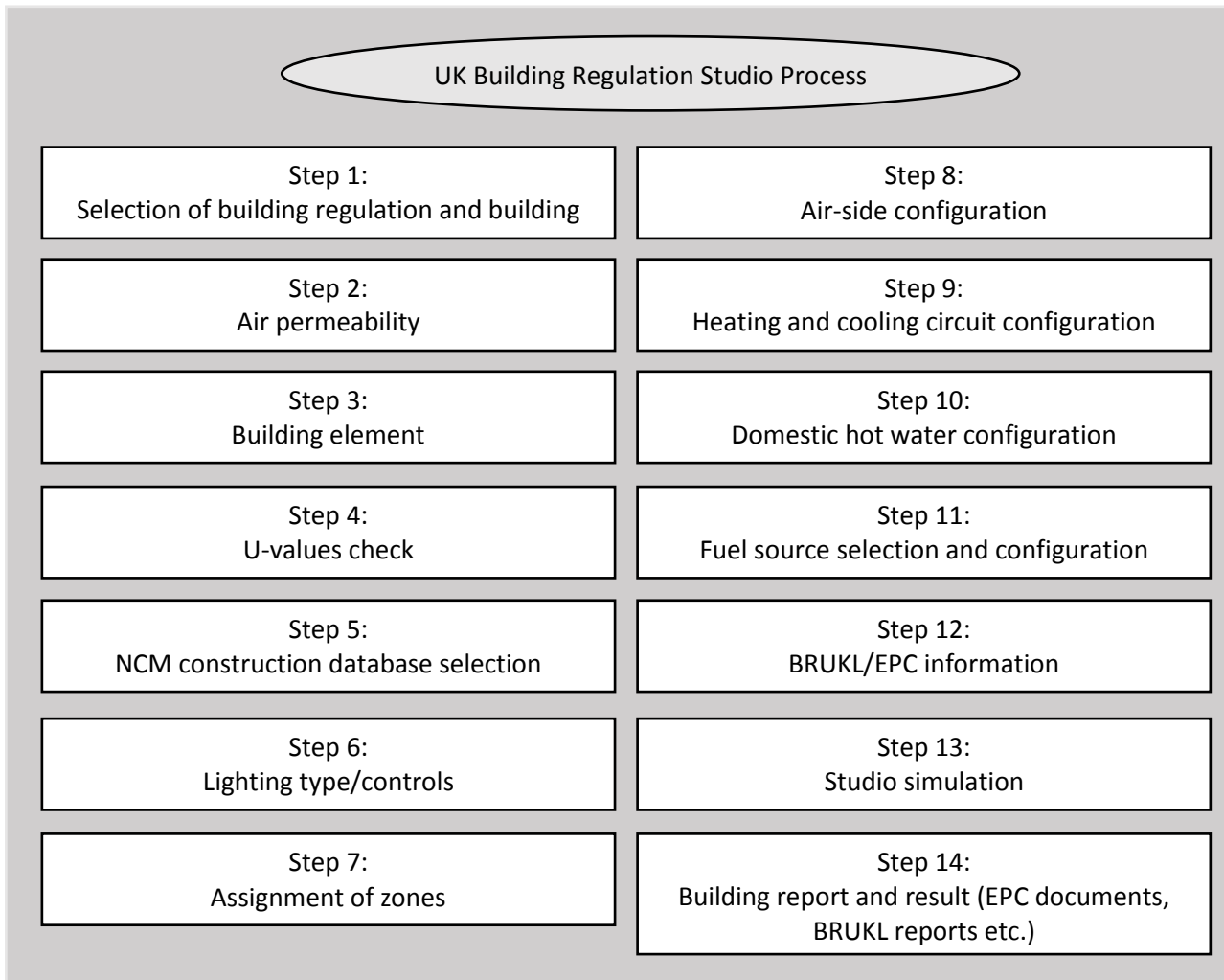

Figure 3.6: TAS UK Building Regulation Studio Process

Chapter 4: Estimation and Validation of Energy Consumption in Existing Hotel Buildings in the UK Using Dynamic Simulation Software

4.1 Introduction

As highlighted in the preceding sections, buildings contribute to almost half of the energy consumption in western countries and it has become imperative to meaningfully reduce their energy consumption and associated CO₂ emissions. Moreover, to curb increasing building energy consumption, it is equally important to comprehend the distribution of energy use throughout the building along with how building parameters impacts energy consumption and demand (Langner *et al.*, 2012).

Therefore, in order to achieve building energy consumption abatement and CO₂ emissions reduction it is important to have a relatively accurate estimate of overall energy consumption in new and existing buildings. An accurate estimate of building energy use can be used for several purposes such as justification for proposed refurbishment work, developing budgets for utility costs and to demonstrate compliance with certain regulation requirements. However, investigation building energy consumption is an onerous task as it involves the development of models considering the complex interaction of the building fabric, HVAC system and external environment (Mustafaraj *et al.*, 2014). The dynamic nature of climatic conditions, occupants' behaviour, building operation and several other variables necessitate the use of computer simulation in the design of new buildings and the refurbishment of existing ones. Disadvantages of computer building simulation which are associated with the complexity of a model include the significant amount of comprehensive input data and time, even from skilled designers (Catalina *et al.*, 2008).

It is evident from the review of the literature that a considerable number of studies have been done on improving the prediction and estimation of building energy performance, particularly during the design stage but there is still an existing knowledge gap connected to computing and accounting for unregulated energy consumption estimates. The aim of this case study was to estimate the operational energy consumption of an existing hotel building in the UK with the use of dynamic simulation software (EDSL TAS) and validate the estimated energy consumption with available site consumption data. It presents an approach of improving on the estimate of operational energy which can reduce the expected performance gap between building regulation Part L model and actual building energy use. This study can thus contribute to existing knowledge in improving the prediction and estimation of building energy performance by presenting an approach that can be employed to estimate considerable unregulated energy use such as catering in an existing hotel building. This contribution provides an indication of possible unregulated energy consumption that can be evaluated to help in reducing the performance gap in hotel buildings, particularly as previous studies have demonstrated that accurate estimation of energy consumption in hotel buildings is progressively difficult as a result of the mixed-use nature of hotels accommodating diverse activities.

4.2 Building Description

This section provides building descriptions for Hilton Reading hotel which is the main hotel used for this case study along with that of the other validation cases: Hilton London Heathrow Airport Terminal 4 and Hilton London Gatwick Airport Hotel.

4.2.1 Building description for Hilton Reading Hotel

The Hilton Reading hotel building is located in Reading, Berkshire. The building, constructed in 2009, is a four-storey hotel with underground basement parking. The building is a predominantly single glazed facade, sealed building and fully air conditioned with a total floor area of 12,362m². The windows are typically double glazed (4 mm clear pane; 50 mm air gap and 4 mm clear pane) with a total window area of 1080m² and a window to building envelope area of 30%. The ground floor of the building accommodates the reception area, conference/meeting rooms, restaurant/bar/kitchen and fitness/pool area. While the first, second and third floors accommodate mainly the ensuite bedrooms, the roof houses the plant rooms. The rooftop central air handling units (AHU) provide heating/cooling as well as fresh air to all building floors whilst fan coil units (FCU) provide cooling/heating to individual bedrooms/meeting rooms. The hotel is very busy with a room occupancy rate of over 90% annually. The domestic hot water (DHW) demand in all rooms, kitchens and toilets is met by six gas-fired boilers. Reading, Berkshire is about 40 miles from central London, which is the closest weather station. Therefore, the weather data used for simulation of heating and non-heating season is the current CIBSE London TRY. To facilitate the shadow calculation and orientation in the 3D Modeller, the latitude, longitude and time zone values of 51.43 degrees North, -0.98 degrees East and UTC +0.0 respectively were inputted to reflect the geographical location parameters of the hotel building. Figure 4.1 shows the AutoCAD floor plan drawing for the hotel.

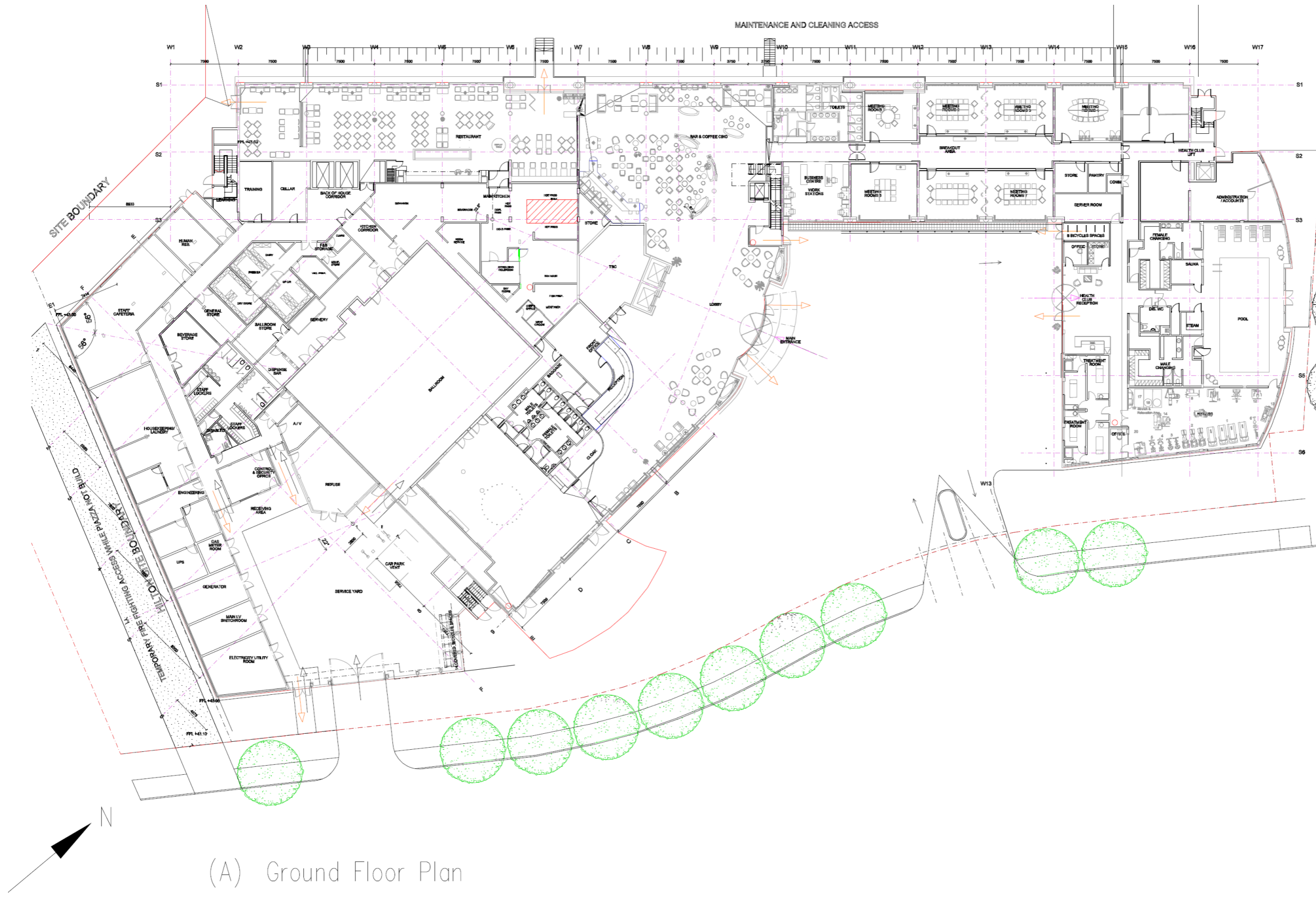

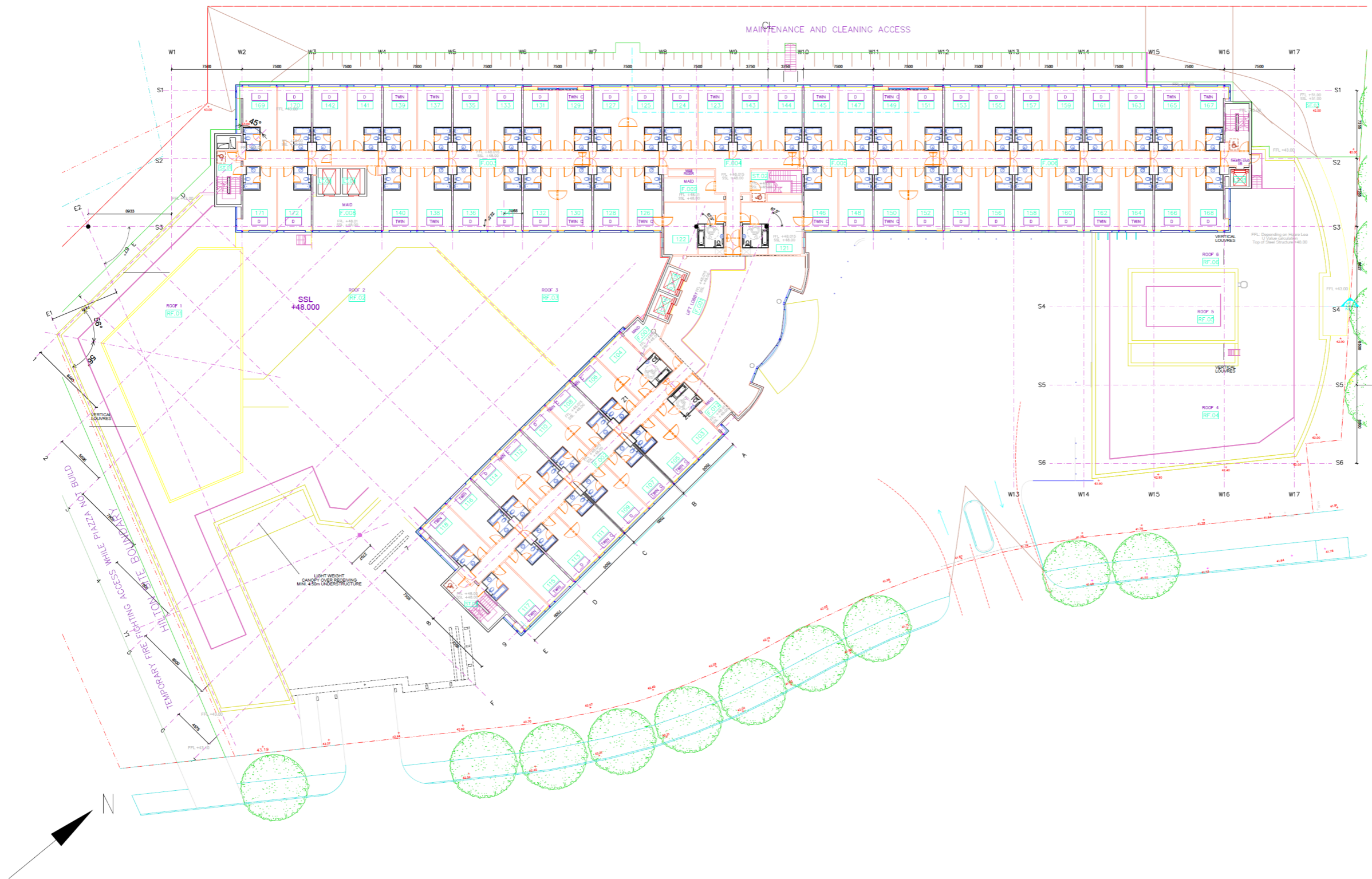

(B) Typical First floor – Third Floor plan

Figure 4.1: Architectural plan of Hilton Reading Hotel

4.2.2 Building description for Hilton London Heathrow Airport Terminal 4

The Hilton London Heathrow Airport Terminal 4 is a six-storey hotel constructed in 1990. It is located in Heathrow and due its closeness to the airport, the building is completely sealed for noise abatement. The building consists of two wings situated either side of a central atrium that runs the entire building height from the first floor and the east and west sides of the atrium space are enclosed by a double skin façade system. Since the building is sealed, it is completely air-conditioned apart from the various plant rooms located on the ground floor and sixth floor. The building has a total floor area of 20,881m², with the ground floor containing the conference/meeting rooms, back of house offices and gym. The central atrium on the first floor contains the restaurant, bar and reception area, while the 395 guest rooms are housed on the first to fifth floors.

A 4-pipe FCU supplies treated air to individual bedrooms with the rooftop central AHU providing additionally fresh air. Cooling is mainly provided by three air-cooled chillers and an additional 13-split AC system provide cooling for one of the large conference rooms, the back of house and server room. The hotel has a CHP unit which provides onsite electricity generation and is sized to satisfy the domestic hot water demand along with a backup boiler. Since the hotel is located in Heathrow, the weather data used for the building energy simulation is the current CIBSE London TRY weather file. To aid in the shadow calculation in the 3D Modeller, the latitude, longitude and time zone values of 51.46 degrees North, -0.44 degrees East and UTC +0.0 respectively were inputted to reflect the geographical location parameter of the hotel building. Figure 4.2 shows the AutoCAD floor plan drawing for the hotel.

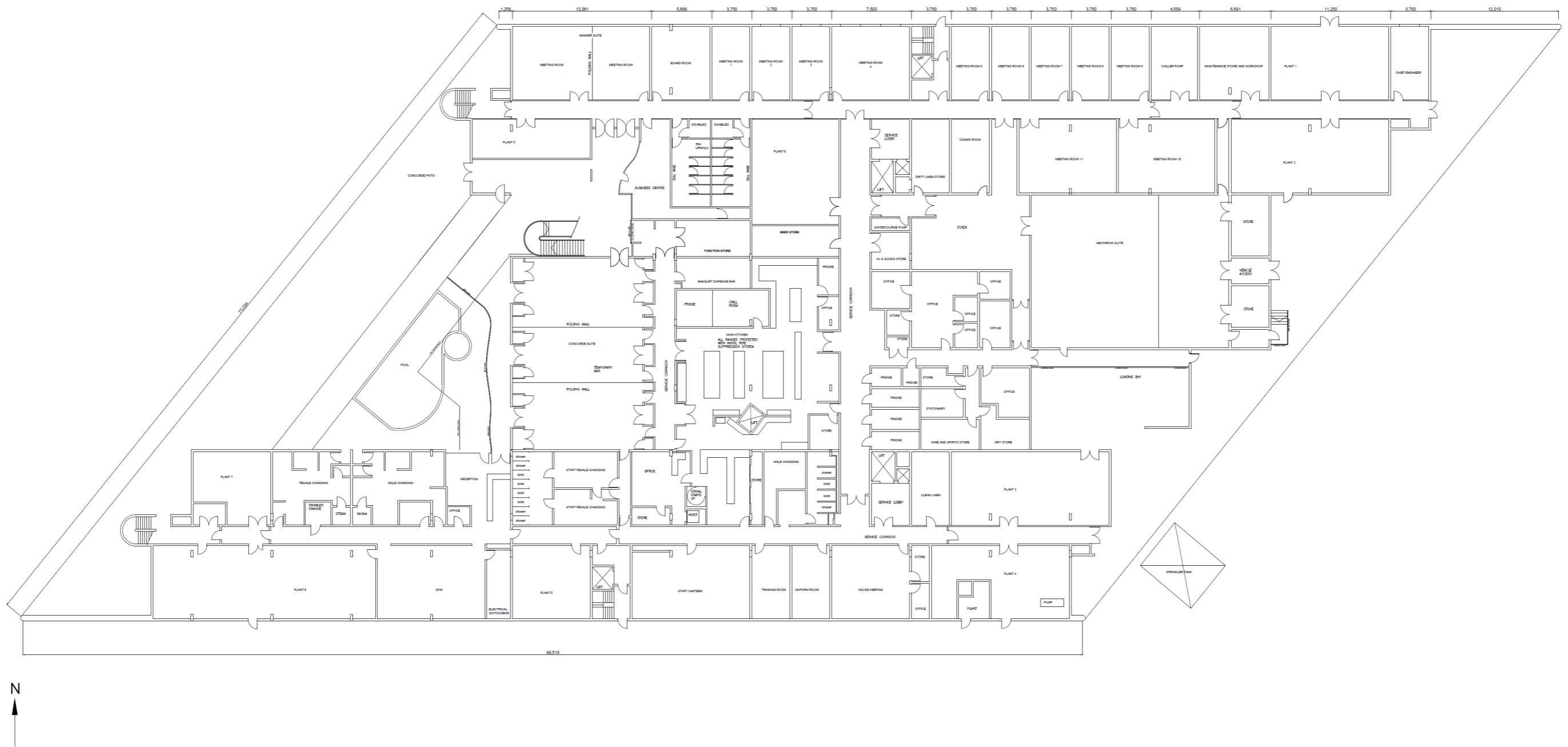

(a) Ground floor plan (Hilton London Heathrow Airport Terminal 4)

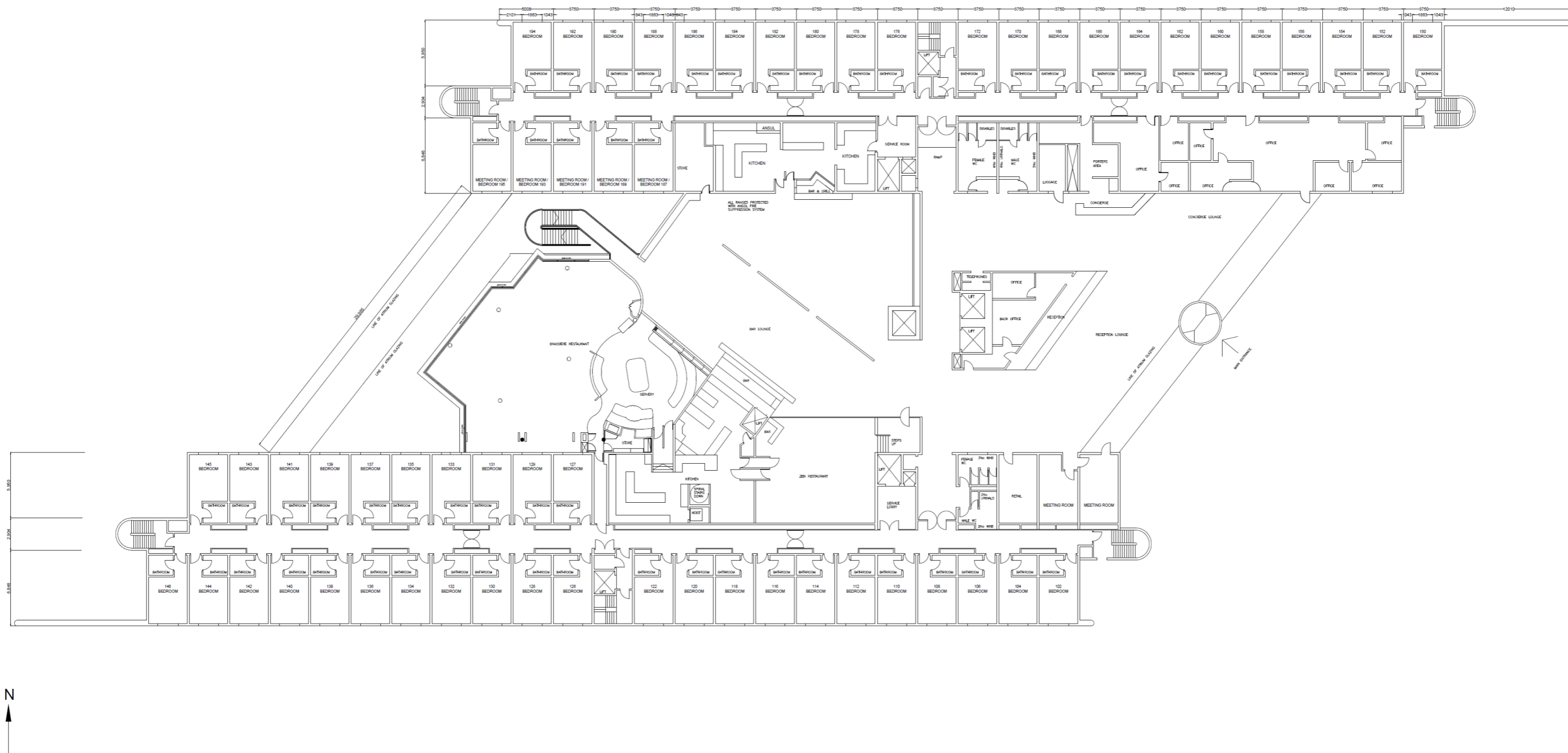

(b) First floor plan (Hilton London Heathrow Airport Terminal 4)

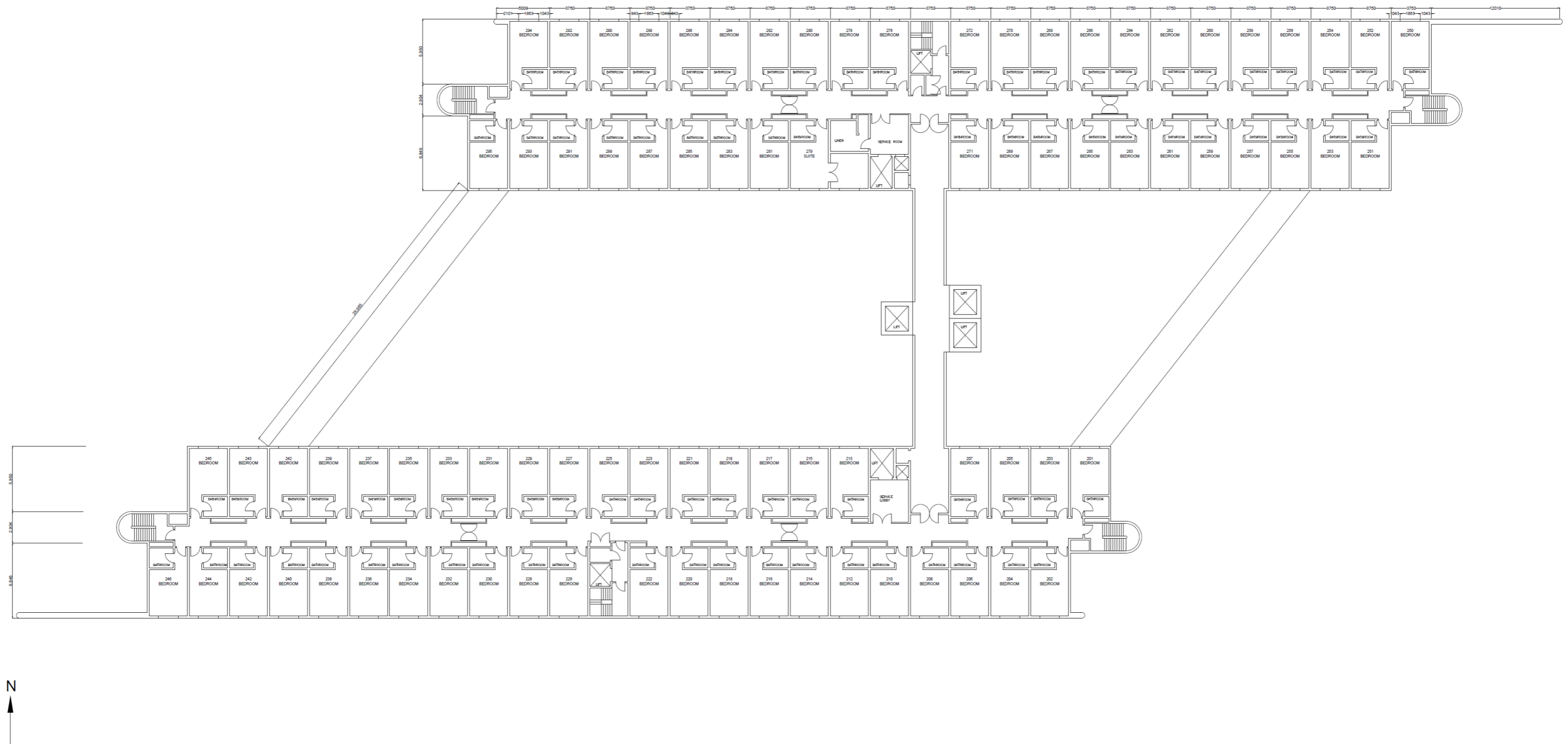

(c) Second floor -fifth floor plan (Hilton London Heathrow Airport Terminal 4)

Figure 4.2: Architectural plan of Hilton London Heathrow Airport Terminal 4 Hotel

4.2.3 Building description for Hilton London Gatwick Airport Hotel

The Hilton London Gatwick Airport Hotel building is located in Gatwick Horley. The hotel structure consists of three integrated five storey buildings with different years of construction. The central main building was constructed in 1981 with two extensions constructed to its north and south ends in 1986, and both buildings house 588 guest rooms served by the same HVAC system. An additional extension to the south was constructed in 2002, consisting of 233 rooms, served by a separate HVAC system. The hotel building is primarily a framed structure with cavity walling and double-glazed windows. The building is mostly air conditioned and sealed for noise abatement due to its proximity to the airport. The hotel has a floor area of 37,236m², conditioned space area of 28,257m² and comprises the main public areas including the foyer, two restaurants, meeting rooms, ballroom, gym, retail units and the back of house areas. The meeting rooms, restaurant and public areas are on the ground floor level while the 821 guest bedrooms are housed on the first to fifth floors.

Most of the occupied spaces, comprising the guest rooms, are served by assigned central air handling units situated in the plant rooms. There are nineteen AHUs supplying conditioned air and they are mainly supply units with separate extract fans. The majority of the AHUs service the main building and are supplied by two air cooled chillers situated in the roof level plant room while two additional smaller chillers service the newer building extension. The AHUs are also fitted with hot water heating coils fed from central gas fired boilers (five boilers in total). The bedrooms are heated and cooled via ducted 4-pipe FCUs hidden within the ceiling. Central chillers and boilers feed the cooling and hot water heating coils within the FCUs and the central AHUs provide additional fresh air through supply air ducts to the back of individual FCUs. Gatwick Horley is

about 28 miles from central London, which is the closest weather station. Therefore, the weather data used for the building energy simulation is the current CIBSE London TRY weather file. To facilitate the shadow calculation and orientation in the 3D Modeller, the latitude, longitude and time zone values of 51.9° North, -0.9 degrees East and UTC +0.0, respectively, were inputted to reflect the geographical location parameters of the hotel building

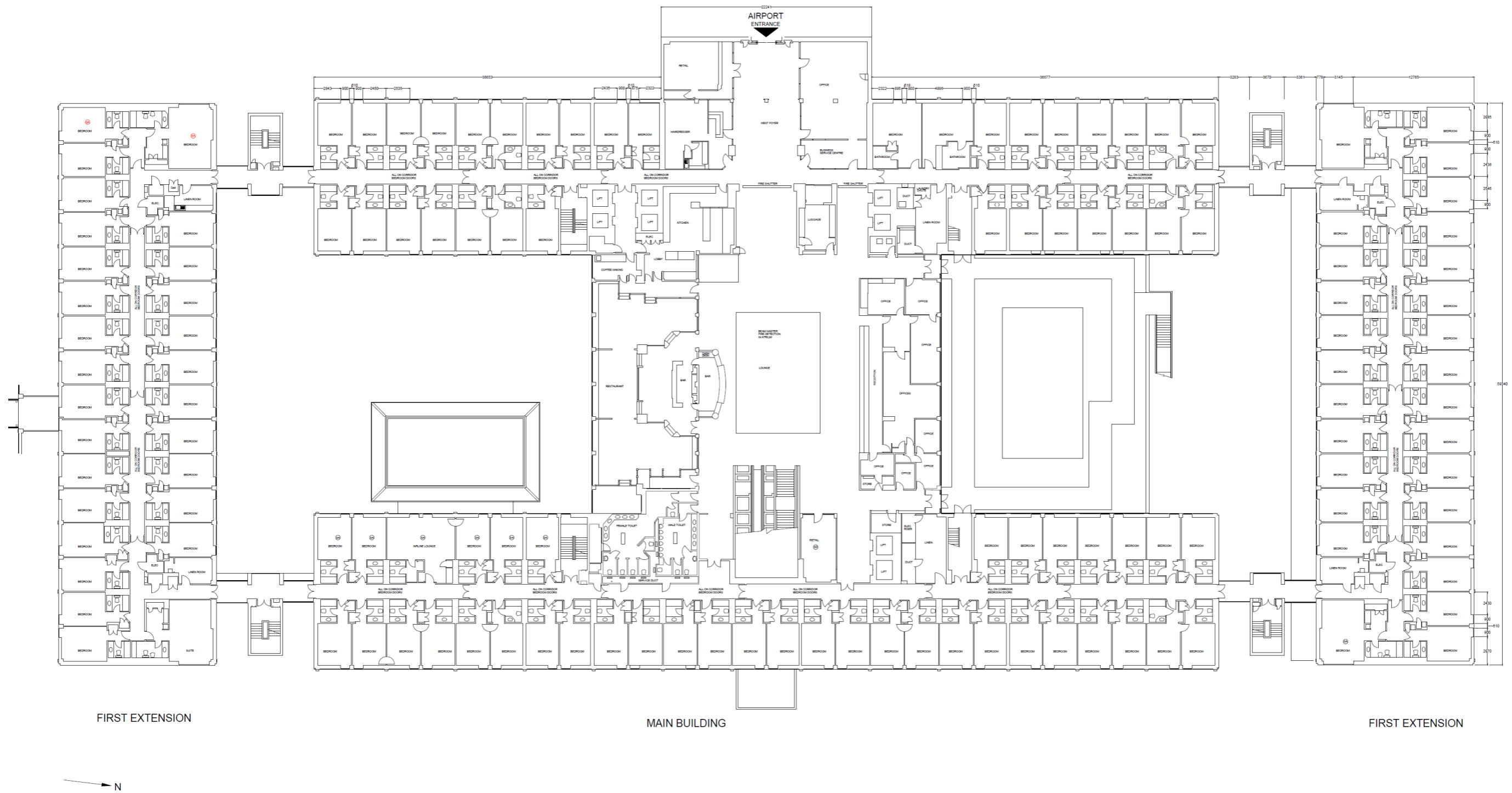

(a) Typical Main building and first Extension floor plan (Hilton London Gatwick Airport hotel)



(b) Typical second extension floor plan (Hilton London Gatwick Airport hotel)

Figure 4.3: Architectural plan of Hilton London Gatwick Airport hotel

4.3 Study Method

The general methodology and core processes that were used to develop the holistic model on the dynamic simulation software TAS are presented in the preceding sections 3.7 to 3.10. However, some information specific to this case study is presented in this section.

In achieving the aim of this study, estimation of the total energy consumption for the model was obtained by two approaches. The first approach evaluated the energy consumption via a UK building regulation part L model and the second approach involved evaluating energy performance through the systems modelling component of the dynamic simulation software. The second approach was then modified to include the estimates for unaccounted building energy use such as catering services. The simulation results were validated by comparing against site measured energy consumption. The case study building was surveyed to enable verification of available data such as building fabric data (e.g. walls and windows), occupancy information to ensure simulation assumptions were realistic, building usage to ensure zone grouping was as shown on the architectural plan and HVAC system characteristics.

Table 4.1: General description of input used in each model

Model	Brief Description	Unregulated Energy Use
Building Regulation model	Typical compliance model simulated with TBD file utilising unedited standard NCM databases for fabric and internal conditions.	Catering energy use not considered.
System/plant model	Bespoke energy model simulated via system modelling component of software	Catering energy use not considered.

	using customised TBD. The TBD file uses	
	editable internal conditions that reflect	
	operational building parameters (such as	
	occupancy hours and temperature set-	
	point).	
	Bespoke energy model simulated via	
	system modelling component of software	
System model +	using customised TBD. The result is	Catering energy use
Catering	modified by accounting for unregulated	accounted for using
	catering	benchmark.
	energy use.	

4.3.1 3D modelling

The information used to develop the 3D model for building simulation was gathered from the AutoCAD drawing of the hotel buildings. These drawings, as highlighted in preceding section 3.7 provide necessary data on the building geometry, layout and functional use of the various zones of the building. Figures 4.1 (a and b); 4.2 (a – c) and 4.3 shows the AutoCAD plans for individual floors of the Hilton Reading hotel, Hilton London Heathrow Airport Terminal 4 and Hilton London Gatwick Airport Hotel respectively.

4.3.2 Simulation process

The dynamic thermal simulation aspect of the modelling was done by the TAS building modeller component of the software and judicious selection of modelling parameters was essential. The required simulation parameters of calendar, weather data, building elements, zones, internal condition and aperture types were populated to perform the thermal performance of the building. From the site data and visitation, the building fabric of the Hilton Reading hotel was found to be in conformity with the part L building regulation 2006. Possible reason for this is that the 2006 building regulation was the latest building regulation during the building's design phase, since the building was completed in 2009. Similarly, site data and visitation of the Hilton London Heathrow Airport Terminal 4 indicated that the building fabric of the hotel was in conformity with 1980/85 Building Regulation, which was the latest building regulation during the building's design phase that was constructed in 1990. Figure 3.3 in section 3.7 illustrates the thermal simulation process employed. Tables 4.2 - 4.4 show modelling parameters and assumptions based on the case study building's characteristics for Hilton Reading hotel. While Tables 4.5 – 4.7 presents the modelling parameters and assumptions base the case study building's characteristics for Hilton London Heathrow Airport Terminal 4 hotel. Additionally, Tables 4.8 - 4.10 show the show modelling parameters and assumptions for Hilton London Gatwick Airport hotel.

Table 4.2: Modelling and simulation parameters based on the case study building's characteristics (Hilton Reading hotel)

Building fabric	Source: Building data	
Calculated individual building element U-values based on the composition of the building fabric construction	External wall	0.24 W/m ² K
	Internal wall	0.24 W/m ² K
	Glazed Curtain wall	2.768 W/m ² K
	Floor	0.24 W/m ² K
	Roof	0.159 W/m ² K
	Windows	2.770 W/m ² K
	Doors (personnel doors)	1.46 W/m ² K
	Main entrance door	1.63 W/m ² K
	Average U-values	1.03 W/m ² K
Windows light transmittance	75%	
Average conductance	10807 W/K	
Alpha values	9.33%	
Fuel source	Natural gas	CO ₂ factor – 0.184 Kg/kWh (BEIS, 2018b)
	Grid electricity	CO ₂ factor – 0.281 Kg/kWh (BEIS, 2018b)

Table 4.3: Modelling and simulation assumptions based on NCM building type and use for Hilton Reading Hotel

Construction database	NCM Construction v5.2.tcd	
Occupancy levels; people density; lux level	Restaurant	0.2 person/m ² , 150 lux
	Car park	0.0059 person/m ² , 100 lux
	Changing room	0.112 person/m ² , 100 lux
	Circulation area	0.115 person/m ² , 100 lux
	Bedroom	0.094 person/m ² , 100 lux
	Gym	0.14 person/m ² 150 lux
		0.108 person/m ² , 500 lux
	Food prep/kitchen	lux
		0.183 person/m ² , 300 lux
	Hall	lux
		0.106 person/m ² , 400 lux
	Office	lux
	Plant room	0.11 person/m ² , 200 lux

	Reception	0.105 person/m ² , 200 lux
	Store	0.11 person/m ² , 50 lux
	Swimming pool area	0.14 person/m ² , 300 lux
	Toilet	0.1188 person/m ² , 200 lux
Calendar	NCM Standard	
Air permeability	5 m ³ /(h.m ²) at 50 Pa	

Table 4.4: Summary of building services input (Hilton Reading hotel)

Building services (source: building data)		
Lighting	LED	Efficiency = 27.5 lumens/w
HVAC	AHU	14 No's [Total air volume rate = 37900l/s; Specific Fan Power (SFP) = 1.5kW/m ² /s - 3.20 kW/m ² /s]
	Chiller	2 air cooled chillers [Total capacity = 1514kW; system efficiency = 85%]
	Boiler	5 boilers [Total capacity 5215kW; system efficiency = 80%]

Table 4.5: Modelling and simulation parameters based on the case study building's characteristics (Hilton London Heathrow Airport Terminal 4)

Building fabric		Source: Building data
Calculated individual building element U-values based on the composition of the building fabric construction	Wall	0.61 W/m ² K
	Floor	0.84 W/m ² K
	Roof	0.83 W/m ² K
	Windows	2.52 W/m ² K
	Doors	2.48 W/m ² K
	High usage entrance door	2.53 W/m ² K
	Average U-values	0.98 W/m ² K
Windows light transmittance		71%
Average conductance		14558 W/K
Alpha values		6.59%
Fuel source	Natural gas	CO ₂ factor – 0.184 Kg/kWh (BEIS, 2018b)
	Grid electricity	CO ₂ factor – 0.281 Kg/kWh (BEIS, 2018b)

Table 4.6: Modelling and simulation assumptions based on NCM building type and use for Hilton London Heathrow Airport Terminal 4

Construction data base	NCM Construction v5.2.tcd	
Occupancy levels; people density; lux level	Restaurant	0.2 person/m ² , 150 lux
		0.119 person/m ² , 100 lux
	Changing room	lux
		0.115 person/m ² , 100 lux
	Circulation area	lux
		0.094 person/m ² , 100 lux
	Bedroom	lux
		0.140 person/m ² , 150 lux
	Gym	lux
		0.108 person/m ² , 500 lux
	Food prep/kitchen	lux
		0.183 person/m ² , 300 lux
	Hall	lux
		0.106 person/m ² , 400 lux
	Office	lux
		0.11 person/m ² , 200 lux
	Plant room	lux
		0.105 person/m ² , 200 lux
	Reception	lux
		lux

	Store	0.11 person/m ² , 50 lux
	Swimming pool area	0.14 person/m ² , 300 lux
	Toilet	0.118 person/m ² , 200 lux
Calendar	NCM Standard	
Air permeability	5 m ³ /(h.m ²) at 50 Pa	

Table 4.7: Summary of building services input (Hilton London Heathrow Airport Terminal 4)

Building services (source: building data)		
Lighting	LED	Efficiency = 27.5 lumens/w
HVAC	AHU	12 No's [Total air volume rate = 64000l/s; SFP = 1.47kW/m ² /s - 3.57 kW/m ² /s]
	Chiller	3 air cooled chillers [Total capacity = 1600kW; system efficiency = 80%]
	Split AC	13 split ACs [Total capacity 116kW; system efficiency = 85%]
	CHP	Size = 302kWe; Heat to power ratio = 1.2; system efficiency = 90%
	Boiler	4 boilers [Total capacity 2,394kW; system efficiency = 78%]

Table 4.8: Modelling and simulation parameters based on the case study building's characteristics
(Hilton London Gatwick Airport)

Building fabric		Source: Building data
Calculated individual building element U-values based on the composition of the building fabric construction	Wall	0.61 W/m ² K
	Floor	0.84 W/m ² K
	Roof	0.15 W/m ² K
	Windows	3.39 W/m ² K
	Doors	3.35 W/m ² K
	High usage entrance door	2.53 W/m ² K
	Average U-values	0.81 W/m ² K
Windows light transmittance	75%	
Average conductance	35995 W/K	
Alpha values	9.14%	
Fuel source	Natural gas	CO ₂ factor – 0.184 Kg/kWh (BEIS, 2018b)
	Grid electricity	CO ₂ factor – 0.281 Kg/kWh (BEIS, 2018b)

Table 4.9: Modelling and simulation assumptions based on NCM building type and use for Hilton London Gatwick Airport)

Construction data base	NCM Construction v5.2.tcd	
Occupancy levels; people density; lux level	Restaurant	0.2 person/m ² , 150 lux
		0.119 person/m ² , 100 lux
	Changing room	lux
		0.115 person/m ² , 100 lux
	Circulation area	lux
		0.094 person/m ² , 100 lux
	Bedroom	lux
		0.140 person/m ² , 150 lux
	Gym	lux
		0.108 person/m ² , 500 lux
	Food prep/kitchen	lux
		0.183 person/m ² , 300 lux
	Hall	lux
		0.106 person/m ² , 400 lux
	Office	lux
		0.11 person/m ² , 200 lux
Plant room	lux	
	0.105 person/m ² , 200 lux	
Reception	lux	
	lux	

	Store	0.11 person/m ² , 50 lux
	Toilet	0.118 person/m ² , 200 lux
Calendar	NCM Standard	
Air permeability	5 m ³ /(h.m ²) at 50 Pa	

Table 4.10: Summary of building services input (Hilton London Gatwick Airport)

Building services (source: building data)		
Lighting	LED	Efficiency = 27.5 lumens/w
HVAC	AHU	19 No's [Total air volume rate = 46800l/s; SFP = 1.5kW/m ² /s - 3.20 kW/m ² /s]
	Chiller	4 air cooled chillers [Total capacity = 2866kW; system efficiency = 85%]
	Split AC	12 split ACs [Total capacity 213kW; system efficiency = 85%]
	Boiler	5 boilers [Total capacity 5,990kW; system efficiency = 80%]

The UK building regulation component of EDSL TAS, which is based on the 2013 building regulations was also used for this case study. This performed energy and thermal simulations of the building subject to NCM standards for compliance purposes. The building regulation model was done by systematically going through the regulation studio of the program and selecting

appropriate parameters to develop the building's plant circuit arrangement, which translates to generation of various building reports which included EPC documents, total energy consumption, carbon emissions and fuel use. Figure 3.6 in the preceding section shows the UK building regulation process and Figure 4.4 shows a summary of this case study methodology:

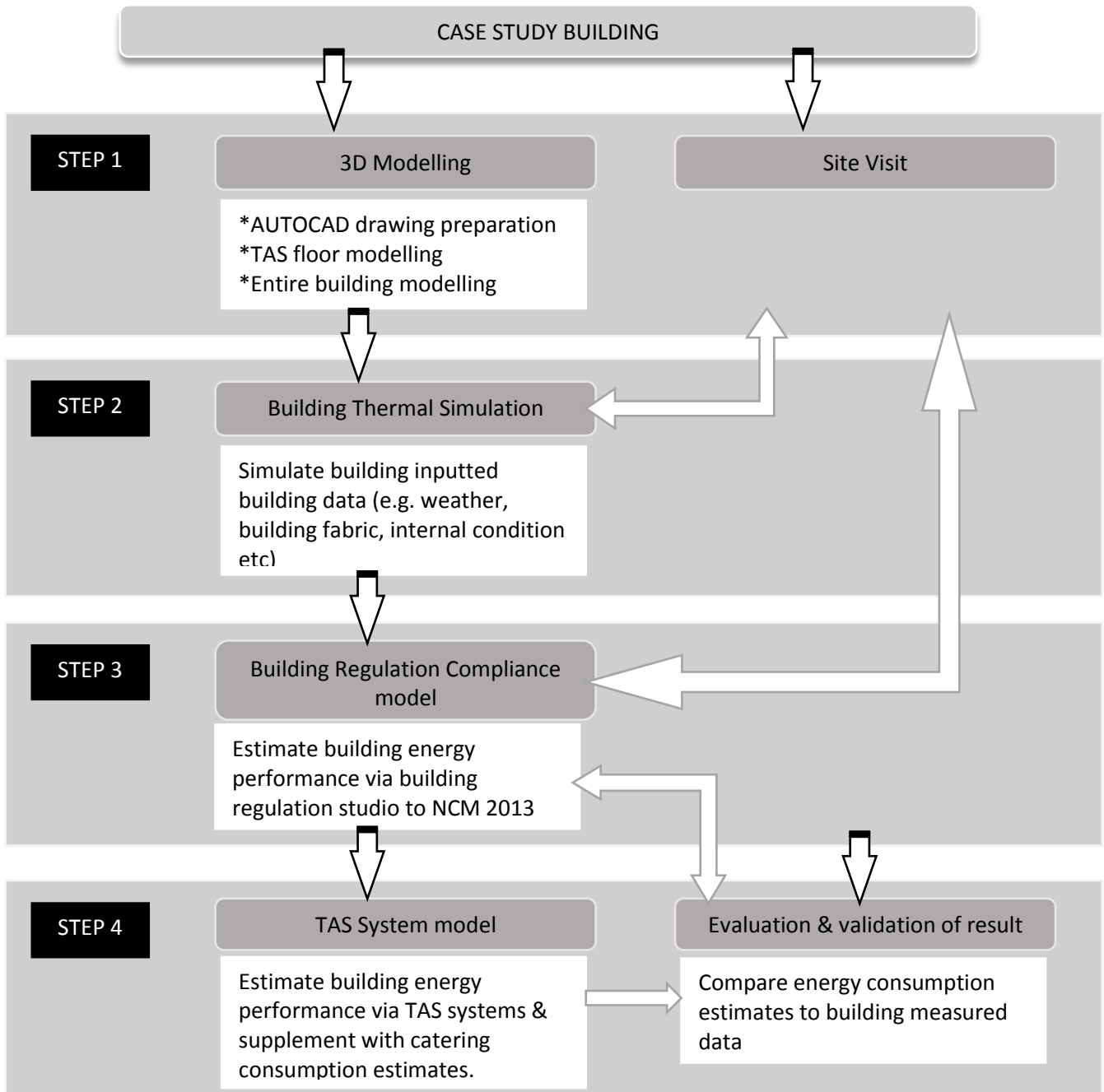

Figure 4.4: Summary of case study methodology for building energy estimation and validation

4.4 Results and Discussion

4.4.1 Energy consumption and validation for Hilton Reading Hotel

The results and discussion of the Hilton Reading case study hotel building are presented in this section. Figures 4.5 and 4.6 illustrate the 2D and 3D model of the building develop in the 3D modeller component of the simulation software.

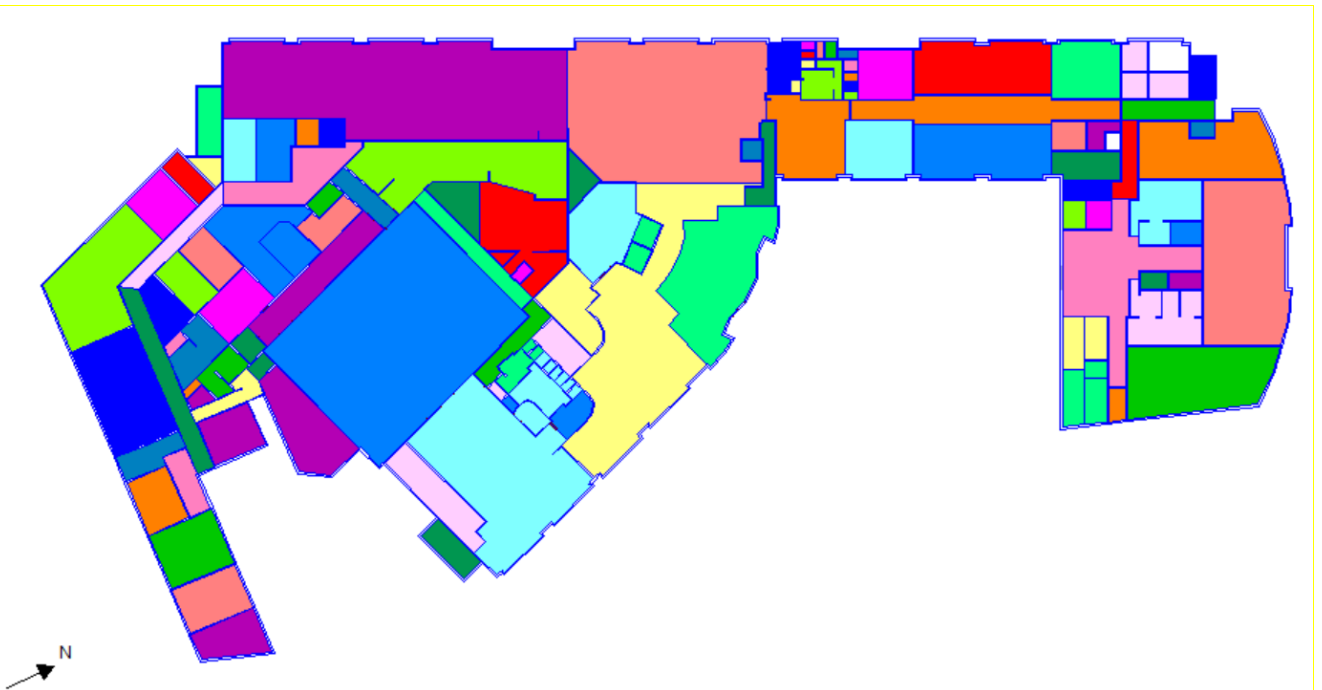

Figure 4.5: Typical floor plan showing floor usage and allocation of zones (Hilton Reading)

Figure 4.5 illustrates a typical 2D floor plan of the 3D modelling process and Figure 4.6 shows the complete 3D model of the building. The different colour codes shown in Figure 4.5 represent the division of the building into various zones based on their peculiar internal condition and usage.

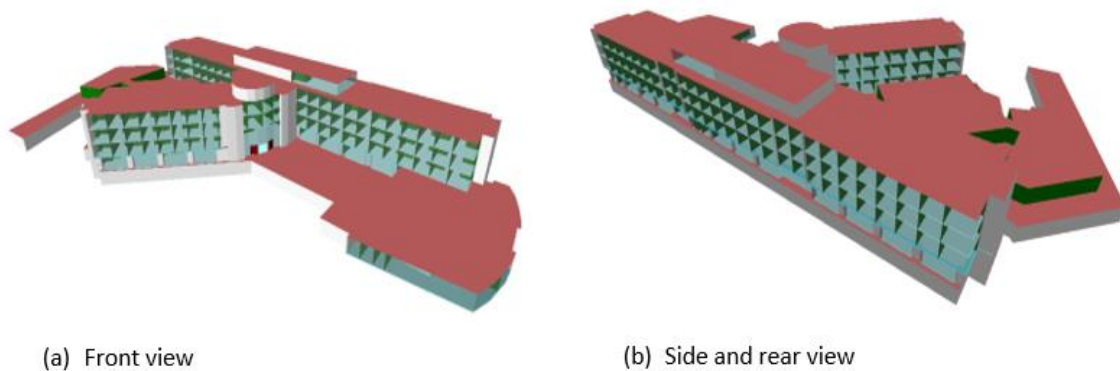
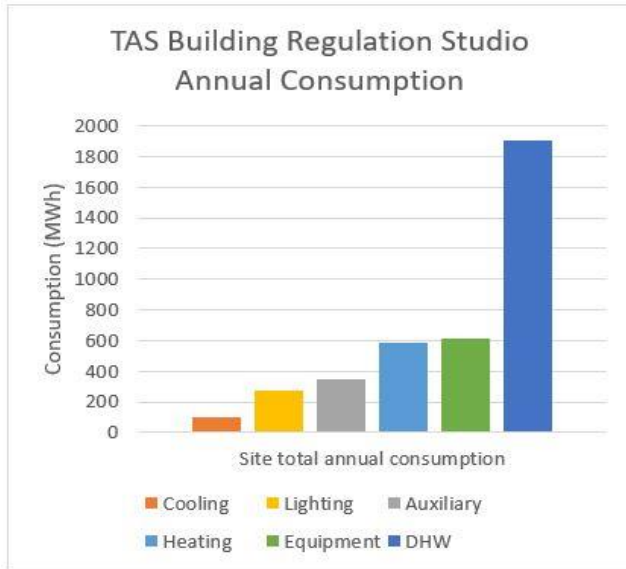
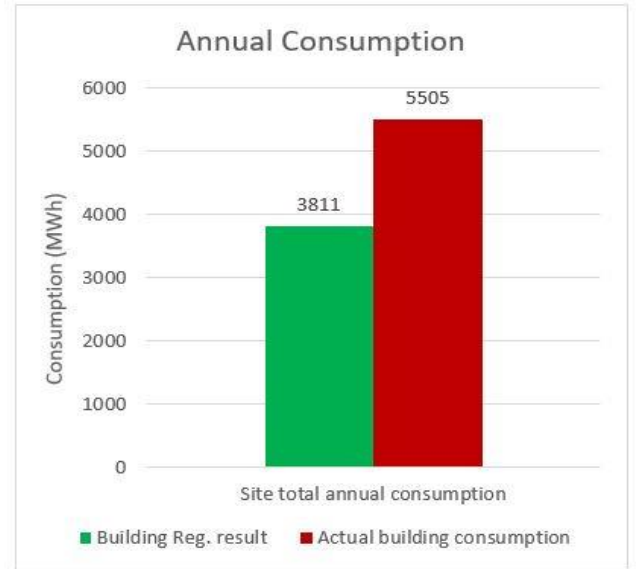

Figure 4.6: TAS 3D model of the building (Hilton Reading)

The populated TAS TBD file was directly attached to the building regulation studio component of the software to obtain Part L energy performance results simulated based on the UK 2013 Building Regulation for England and Wales. Typical results, which include the reports of annual energy consumption, monthly energy consumption simulation of the case study hotel building, are presented in Figures 4.7 to 4.8. The energy consumption estimate comprises heating, cooling, auxiliary, lighting, DHW and equipment energy use.



(a) TAS Building Regulation studio annual energy consumption result



(b) Annual TAS Building Regulation result vs. Actual building consumption

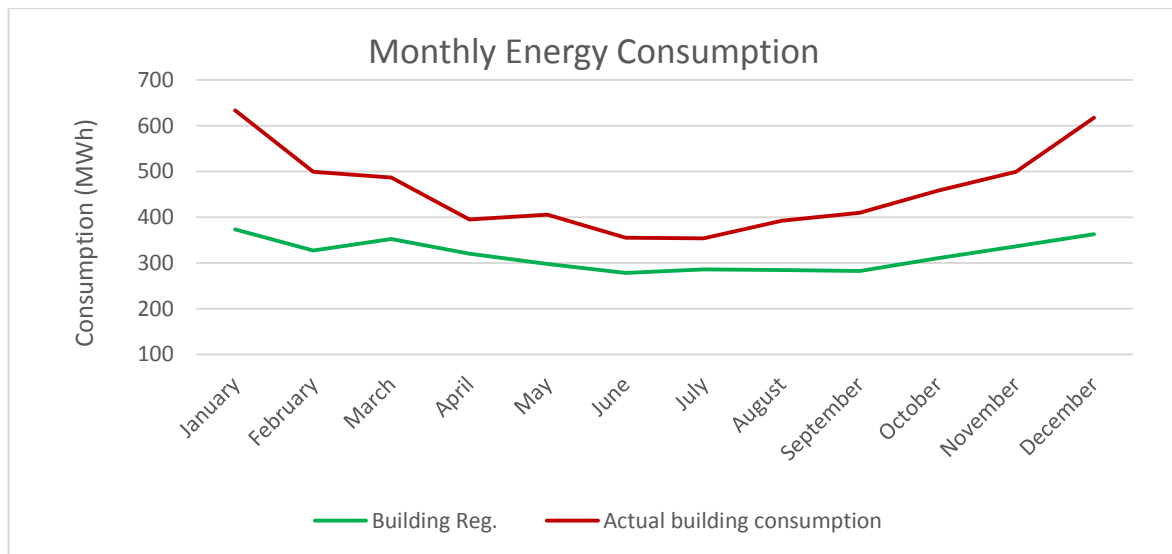

(c) Monthly Building Regulation result vs. Actual building consumption

Figure 4.7 Showing UK Building Regulation simulation results (Hilton Reading)

Figure 4.7(a) demonstrates the breakdown of the annual energy results based on building regulation for various components. Auxiliary energy is the energy used by controls, pumps, and

fans for the HVAC systems. Additionally, there is a standard allowance for small power heat gains in order to calculate the heating and cooling demands which is the equipment energy use.

It can be clearly seen from the analysis of Figures 4.7(b) and (c) that the total energy consumption estimate result via the building regulation simulation is significantly lower compared to the actual building consumption data with a percentage difference of -31% indicating an underestimation. This is primarily because the building studio model is designed to simulate for compliance purposes and this must strictly follow NCM guide, including the use of NCM databases (uneditable building fabric input and internal conditions) and definitions of notional and reference buildings etc. Additionally, the estimated energy does not account for some energy use such as catering services, servers, small power office equipment and the lift. Besides, process energy and some special functions that are considered as specialist activities such as swimming pools and hospital equipments amongst others can result in a sizeable increase in actual building energy consumption which are usually not accounted for in compliance building models (CIBSE, 2013a). Therefore, in the case of swimming pools, the pool internal condition applied to the pool area is used in the building simulation to estimate the DHW demand and internal moisture gains for the zone. From Figure 4.7(c), it can be observed that the energy consumption profile of the TAS building studio results across the year does not differ significantly compared to the actual building measurement, with both profiles showing peak consumption in the heating season and lower consumption during the cooling season.

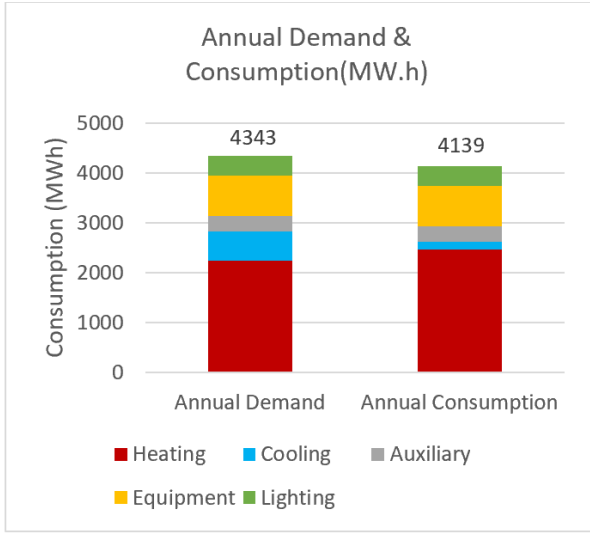

(a) TAS systems result showing annual demand and consumption

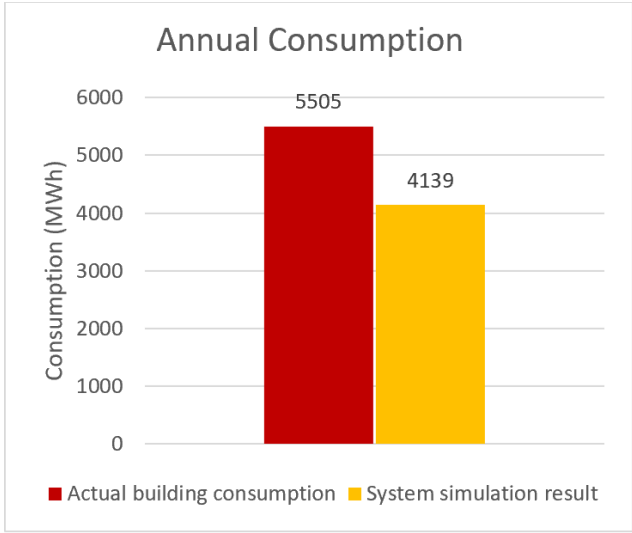

(b) Annual TAS Systems result vs. Actual building consumption

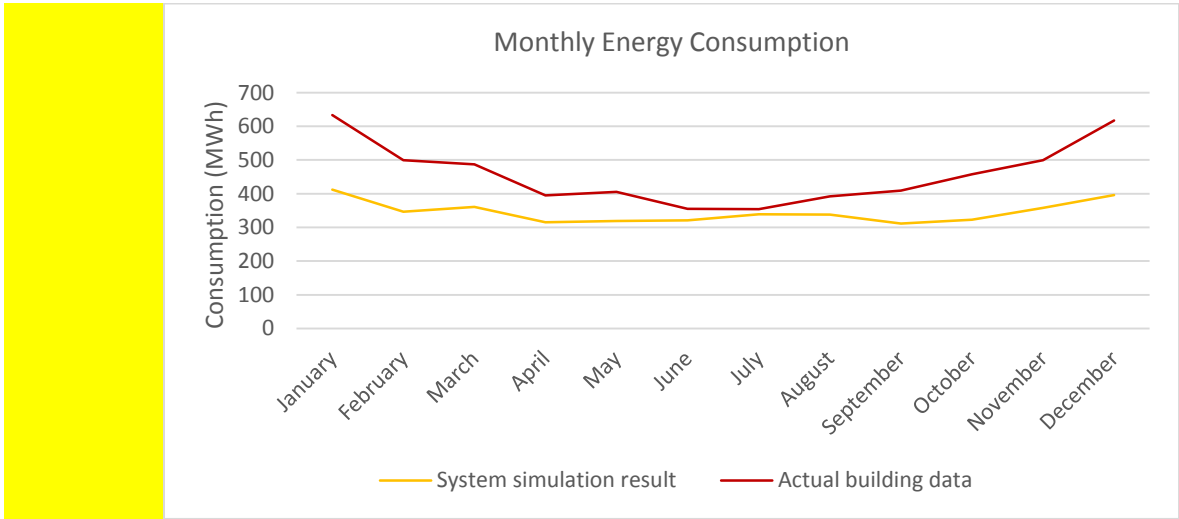

(c) Monthly systems simulation results vs. Actual building consumption

Figure 4.8: Showing Plant/system simulation results (Hilton Reading)

The results of energy consumption estimates obtained from modelling of the plant/systems on the TAS systems component of the software is presented in Figure 4.8.

From Figures 4.8(a) to (c), it is apparent that the energy consumption estimate obtained by simulating the actual systems gives an improved result compared to estimates from building compliance modelling. This is because actual system modelling uses a thermal simulation TSD file that is not evaluated through the building regulation and thus the TSD results are more representative of the actual building condition. Moreover, this simulation is not strictly subjected to NCM guides and databases of standardised internal conditions. However, the comparison of the system simulation result against the actual building consumption data from Figure 4.8(b) shows that TAS system energy consumption results underestimate total annual energy with a percentage estimate of 25%. This discrepancy is a result of some unaccounted energy use including catering, lifts and small power equipment, which are usually not accounted for in building energy models.

The result of energy consumption estimates derived by accounting for expected fossil fuel and electricity consumption associated with catering energy use is presented to improve the model estimate. Since simple reliable calculation estimates for catering energy use are difficult to come by, it is recommended in CIBSE TM 54 that benchmarks be used to estimate commercial kitchens energy use. A typical benchmark that can be utilised for this purpose is adopted from CIBSE TM 50: Energy efficiency in commercial kitchens (CIBSE, 2009), which comprises catering energy benchmarks for various building categories per meal served.

For this case study hotel building, the operational energy benchmark (2.54 kWh for fuel and 1.46 kWh for electricity) for a good practice business/holiday hotel building type was used along with the actual hotel data of number of meals served. Figure 4.9 presents the results for systems simulation plus the catering energy consumption estimate.

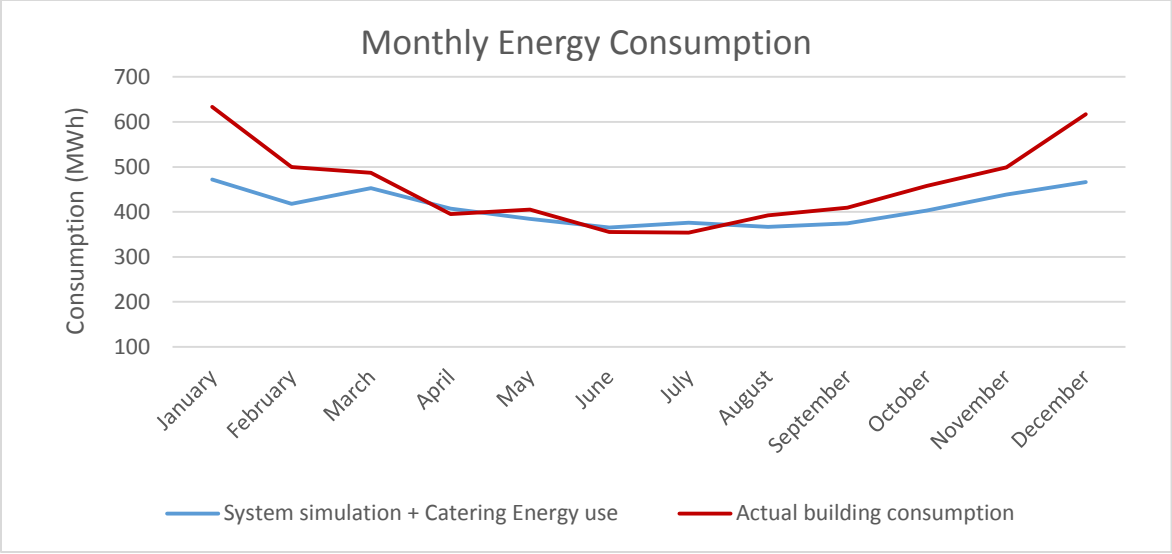

(a) [Monthly systems simulation + Catering energy use result] vs. Actual building consumption

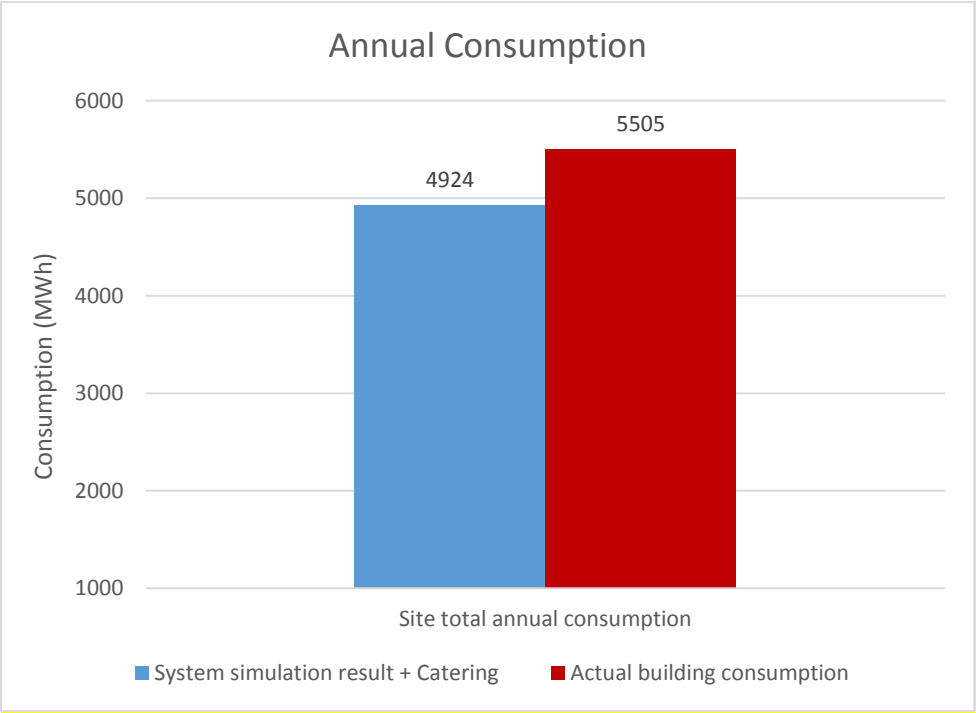

(b) [Annual systems simulation + Catering energy use result] vs. Actual building consumption

Figure 4.9: Showing system simulation + catering energy use results (Hilton Reading)

From Figure 4.9(a) and (b) above it can be seen that the energy consumption resulting from the system simulation augmented with catering energy use gives even better results compared to that

obtained from the building compliance model and the system simulation model. This is mainly because it accounts for unregulated energy use such as catering, which is significant for hotel buildings. Figure 4.9(a) shows that the energy consumption profile of the model matches closely with that of the actual building energy consumption profile especially during the cooling season but this does not appear to be so during the heating season. This indicates that the majority of the error in the model estimate is related to heating energy use with the actual building heating energy use being higher than the model's result. This type of error cannot be totally eliminated as models cannot be an exact representation of reality where the micro-climatic condition is dynamic rather than the average single year TRY weather data used in energy simulation models and where other factors like occupancy/occupant behaviour are difficult to represent accurately. However, from Figure 4.9(b), it can be observed that the comparison of total annual consumption of the TAS systems + catering energy use model gives a significantly improved energy consumption estimate even though it underestimates annual energy consumption by 11%.

While improvement in the overall energy consumption estimate of systems + catering energy use model is encouraging, the result of the breakdown of energy consumption into natural gas and electricity can provide further insight. Figure 4.10 shows the breakdown of annual energy consumption into gas and electricity.

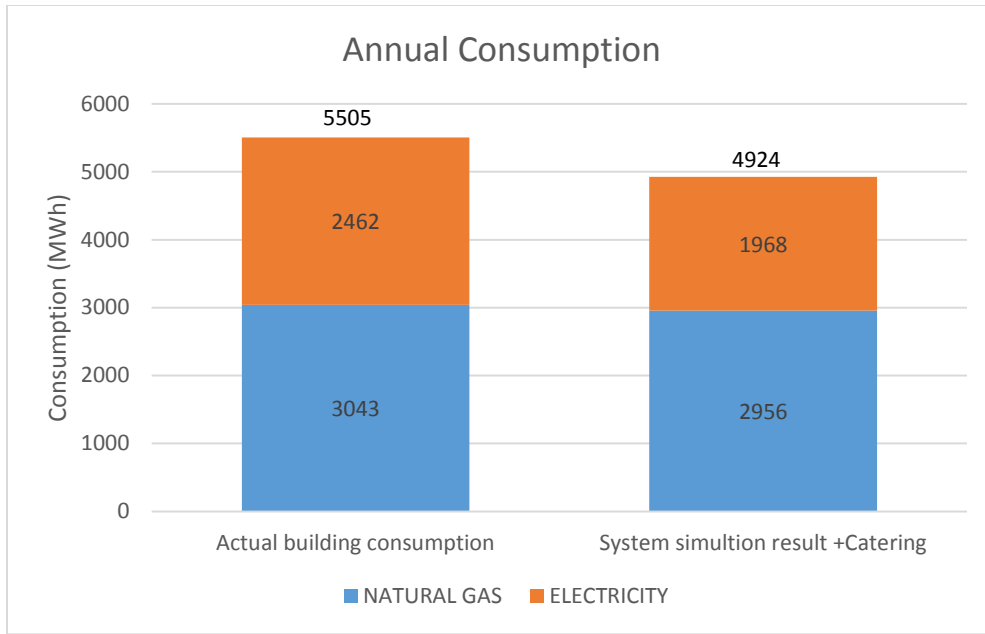
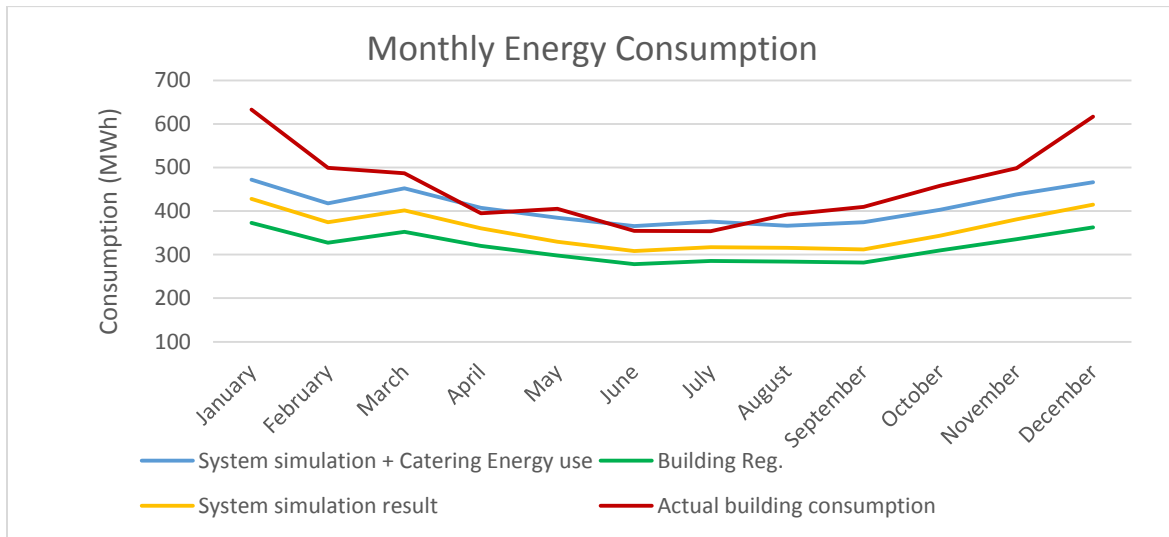

Figure 4.10: Breakdown of annual energy consumption into natural gas and electricity (Hilton Reading).

Figure 4.10 indicates that the building model energy consumption compares relatively well with that of actual building consumption especially for annual natural gas consumption, as the percentage difference between the building model natural gas consumption and actual building data is approximately -3%. While the percentage difference between the building model annual electricity consumption is higher at -20%. The discrepancy in annual electricity consumption can be as result of a number of reasons, especially due to dynamic input data such as weather data, occupant behaviour and building operation. For instance, while it has been acknowledged that building simulation uses a normalised weather data of single year over a baseline period of several years, recent weather trend in the UK have indicated that the climate is generally becoming warmer (Met Office, 2017) with more extreme weather (longer- hotter summers). Therefore, the higher annual electricity consumption from the actual building consumption can be due to the increase in cooling energy requirement in recent micro-climatic condition. However, since the breakdown of

actual building energy consumption into individual end use is not available, it is difficult to determine which end-use is directly responsible for the difference between actual building energy consumption and building model energy consumption.



(a) Monthly system simulation + Catering energy use result vs. Building Reg. vs. Actual building consumption

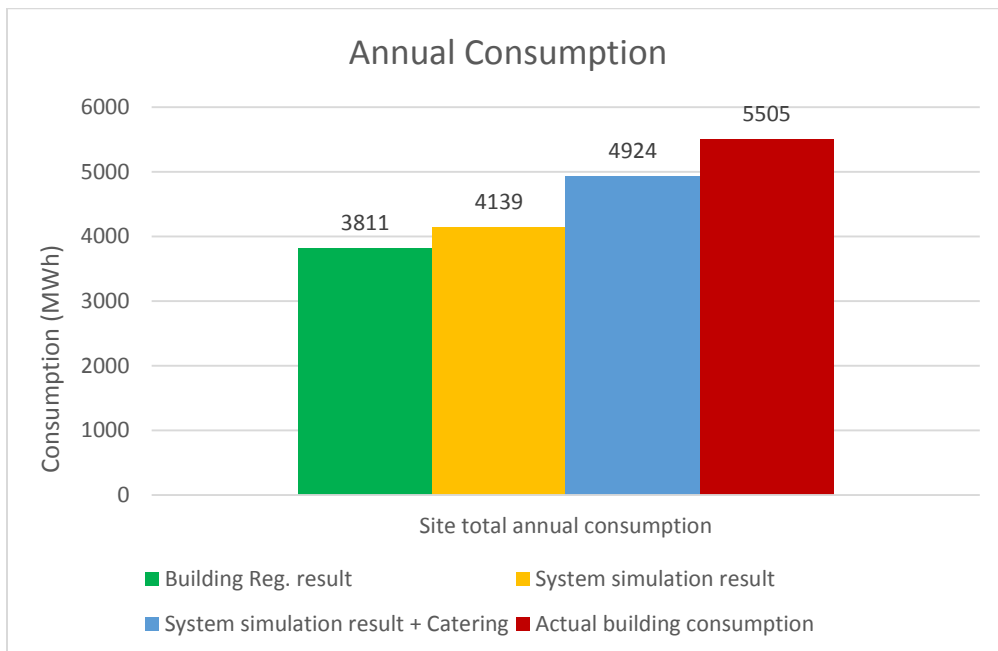

(b) Annual systems result + Catering energy use vs. Building Reg. vs. Actual building consumption

Figure 4.11: Showing systems simulation result + Catering energy use vs. Building Reg. vs. Actual building consumption (Hilton Reading)

Although the three models underestimate total energy consumption compared to the actual building data, Figure 4.11(a) and (b) show a major improvement in energy consumption estimates of the (Systems energy model) and (System simulation + catering energy use) from the Building Regulation compliance model when compared against the actual building data, with the (system simulation model) and (systems simulation + catering model) giving 7% and 20% improvement respectively from the building compliance model.

4.4.2 Energy consumption and validation for Hilton London Heathrow Airport Terminal 4 and Hilton London Gatwick Airport.

This section presents energy consumption and validation results for the remaining case study hotel buildings (Hilton London Heathrow Airport Terminal 4 and Hilton London Gatwick Airport).

Figures 4.12 and 4.13 illustrate the 2D and 3D model of the building develop in the 3D modeller component of the simulation software for Hilton London Heathrow Airport Terminal 4.

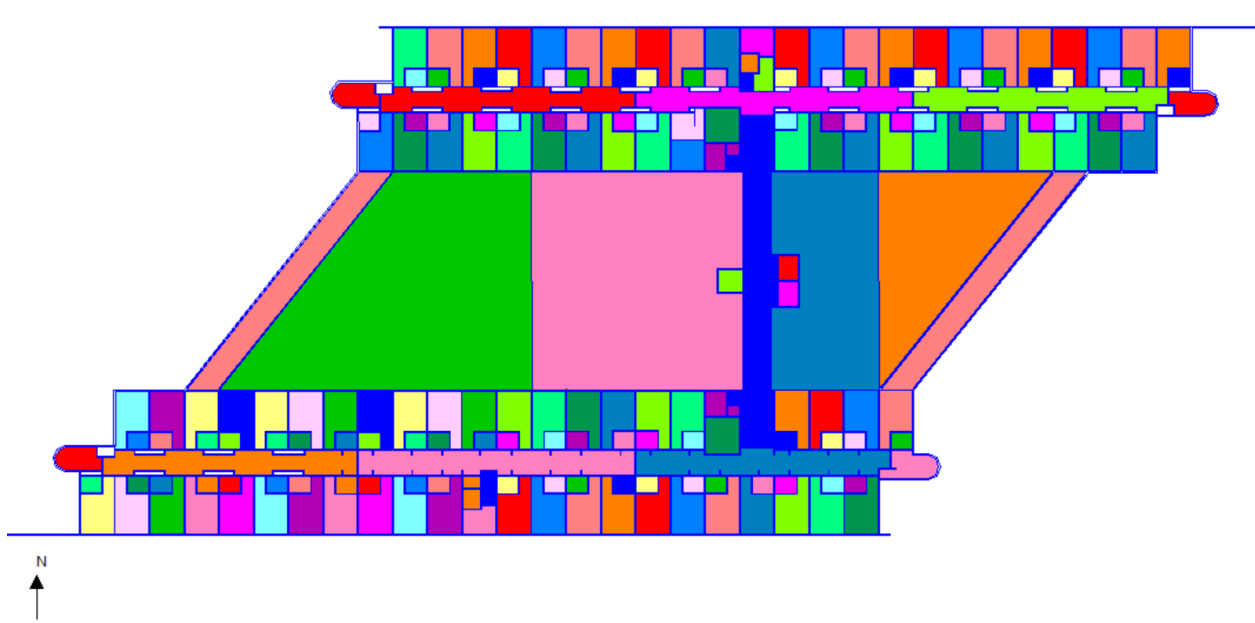
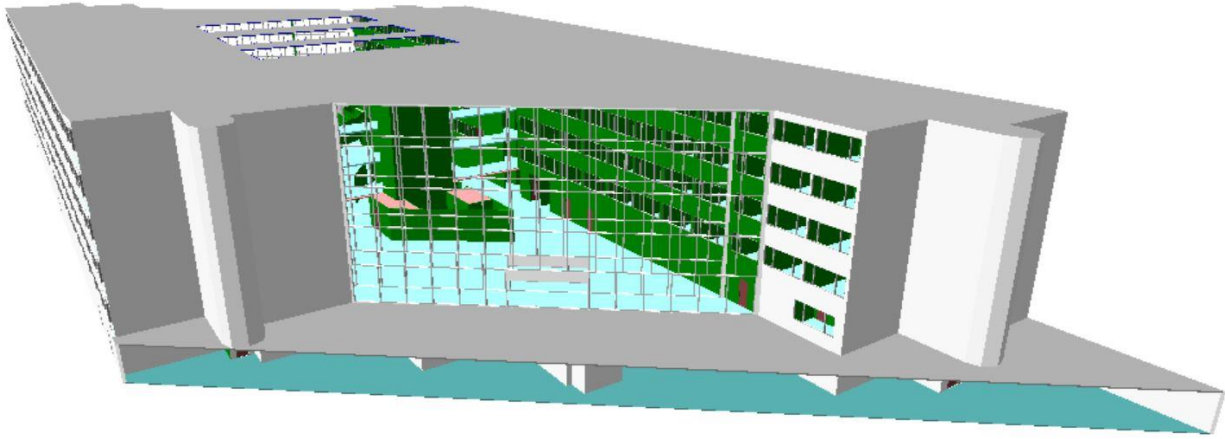
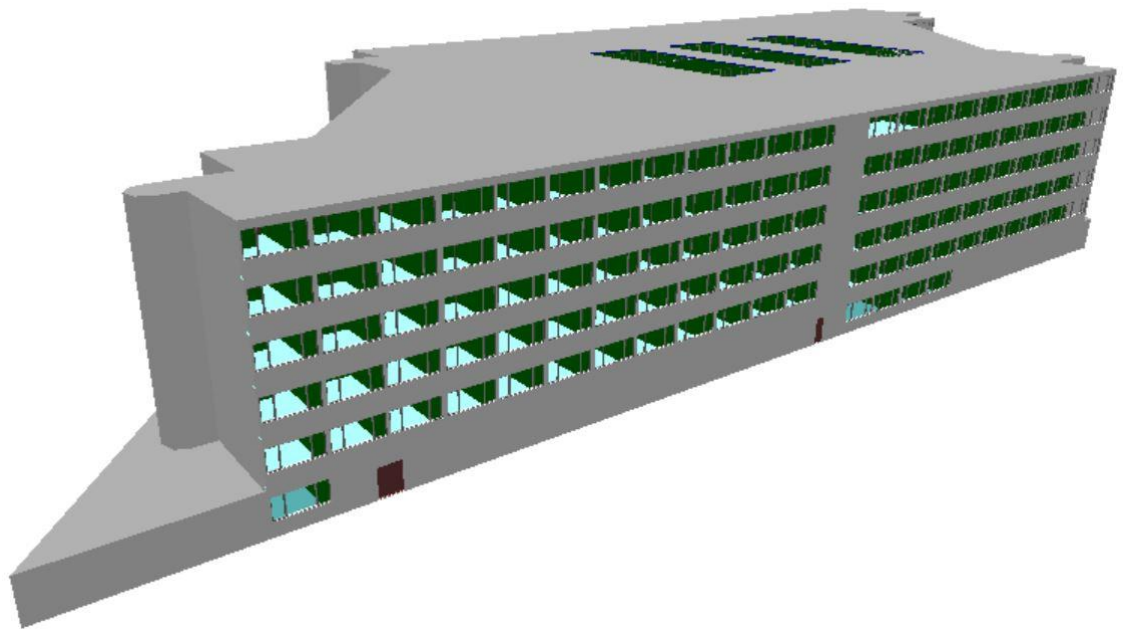

Figure 4.12: Typical floor plan showing floor usage and allocation of zones (Hilton London Heathrow hotel)

In Figure 4.12, which shows a typical 2D floor plan of the 3D modelling process, the different colour codes shown represent the classification of the building into various zones based on their distinctive internal condition and usage.



(a) Front view



(b) Side elevation

Figure 4.13: TAS 3D model of the building (Hilton London Heathrow hotel)

The TAS TBD component of the software is populated appropriately and simulated to reflect the characteristics of the operational building. The simulated TBD file is attached to the system and plant modelling component of the software to obtain energy performance results for the building.

Typical results, which includes reports of the annual energy consumption of the case study hotel building, are presented. The energy consumption estimate comprises heating, cooling, auxiliary, lighting and equipment energy use.

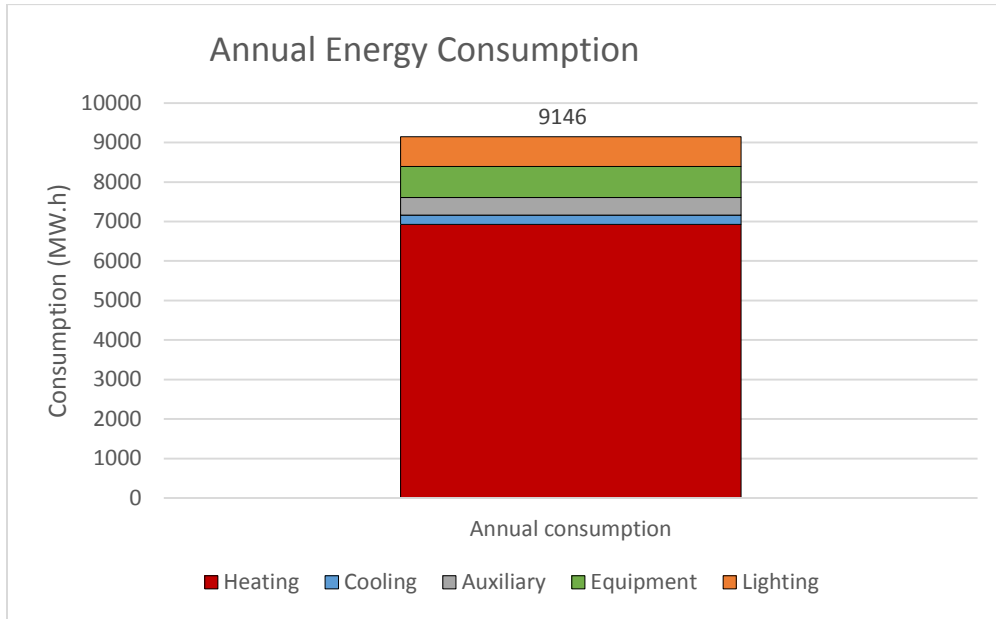

(a) TAS systems simulation result showing annual demand and consumption

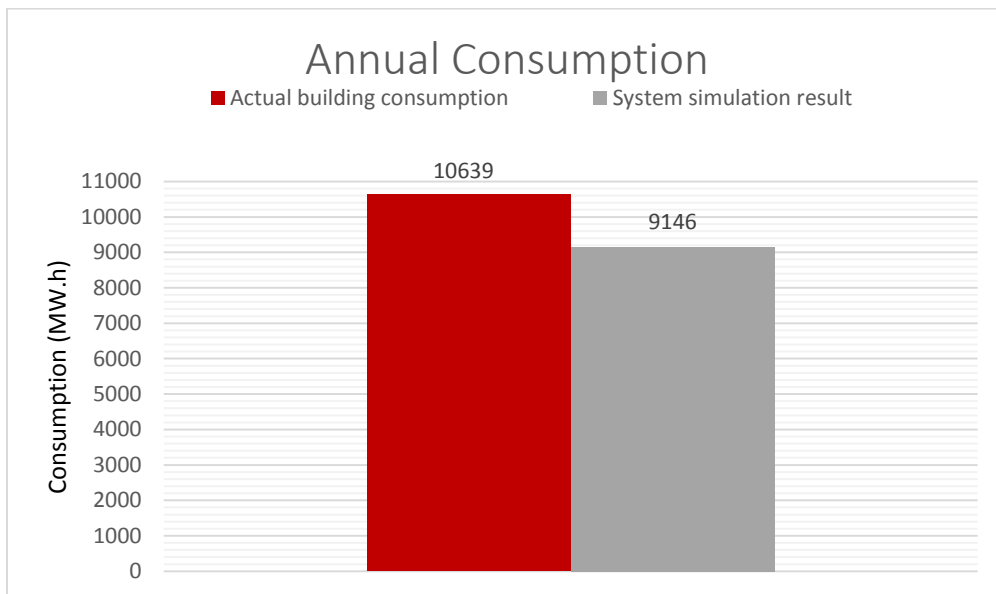

(b) Annual TAS systems result vs. Actual building consumption

Figure 4.14: Energy performance result from plant/system simulation (Hilton London Heathrow hotel)

Figure 4.14(a) illustrates the annual energy demand and consumption for the building obtained via plant/system simulation. It also shows the breakdown of the energy demand and consumption results for heating, cooling, auxiliary, equipment and lighting. Auxiliary energy is the energy used by controls, pumps, and fans for the HVAC systems and the heating includes both space heating and DHW. Additionally, there is a standard allowance for small power heat gains in order to calculate the heating and cooling demands, which is the equipment energy use. From Figure 4.14(b), it can be observed that the total energy consumption predicted via the plant/system modelling is relatively low compared to the actual building consumption data with a percentage error of -14% representing an underestimation. Even though the building fabric and internal condition parameter was judiciously selected to ensure the building simulation replicates real building operation, this discrepancy is still evident. The discrepancy is largely attributed to the fact that the estimated energy does not account for some energy use, referred to as unregulated energy use such as catering services, which can be significant in a hotel building. Additionally, deviation due to the local microclimate of the building's location and the standard weather data used for the building's energy simulation can result in a discrepancy between predicted and actual energy consumption.

Energy use for catering services is estimated and used to augment the result. This is undertaken to further enhance the result and make the baseline model much more acceptable for the evaluation of the impact of the extraction fans on the thermal condition of the adjoining atrium and the overall energy consumption of the Hilton Heathrow hotel building. The catering energy use is estimated using the CIBSE TM54 benchmark for a commercial kitchen, since simple and reliable calculation estimates for catering energy use are difficult to come by. The operational energy benchmark of (2.54 kWh for fuel and 1.46 kWh for electricity) for a good practice business/holiday hotel building

type was used along with the hotel data of number of meals served. Figure 4.15 presents the results for systems simulation including the catering energy consumption estimate:

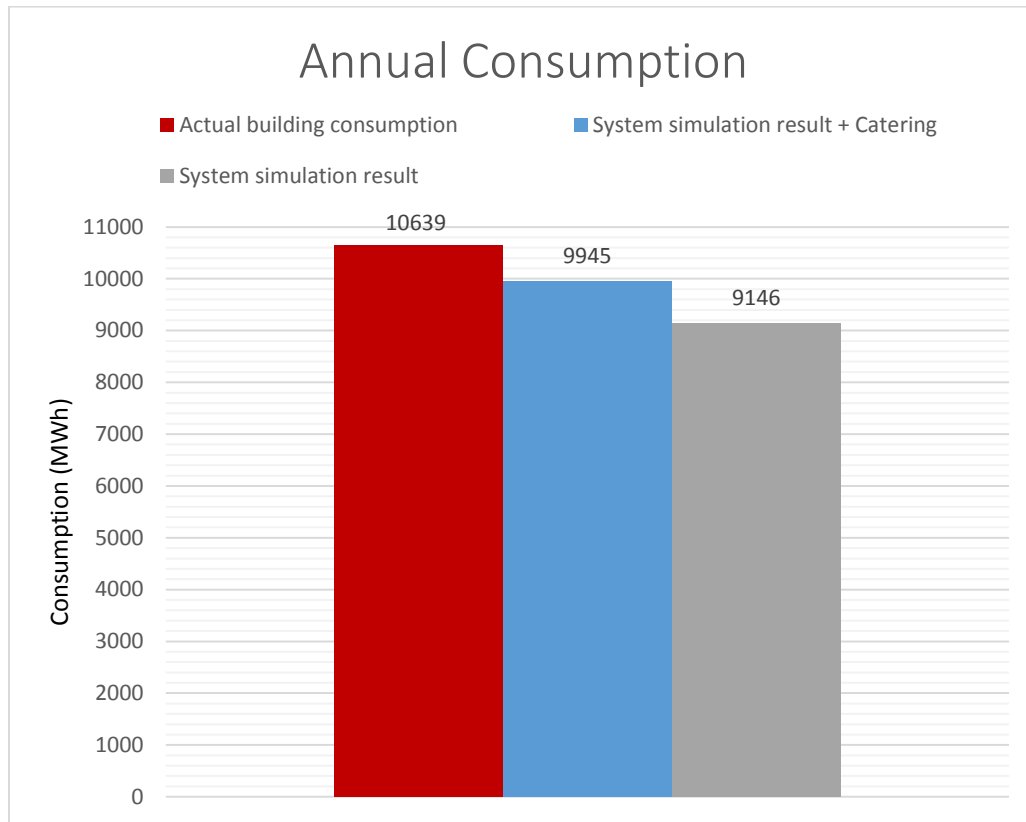

Figure:4.15: Annual systems simulation result + Catering energy use vs. Actual building consumption (Hilton London Heathrow hotel)

It can be observed from Figure 4.15 that the system simulation results supplemented with the catering energy use estimate still underestimate the overall annual energy consumption compared to actual building data. However, the result of the overall energy consumption estimate is significantly improved giving an underestimation of approximately 7%.

To provide further insight of the building energy model consumption estimate compared to the actual building consumption, Figure 4.16 shows the breakdown of annual energy consumption into gas and electricity.

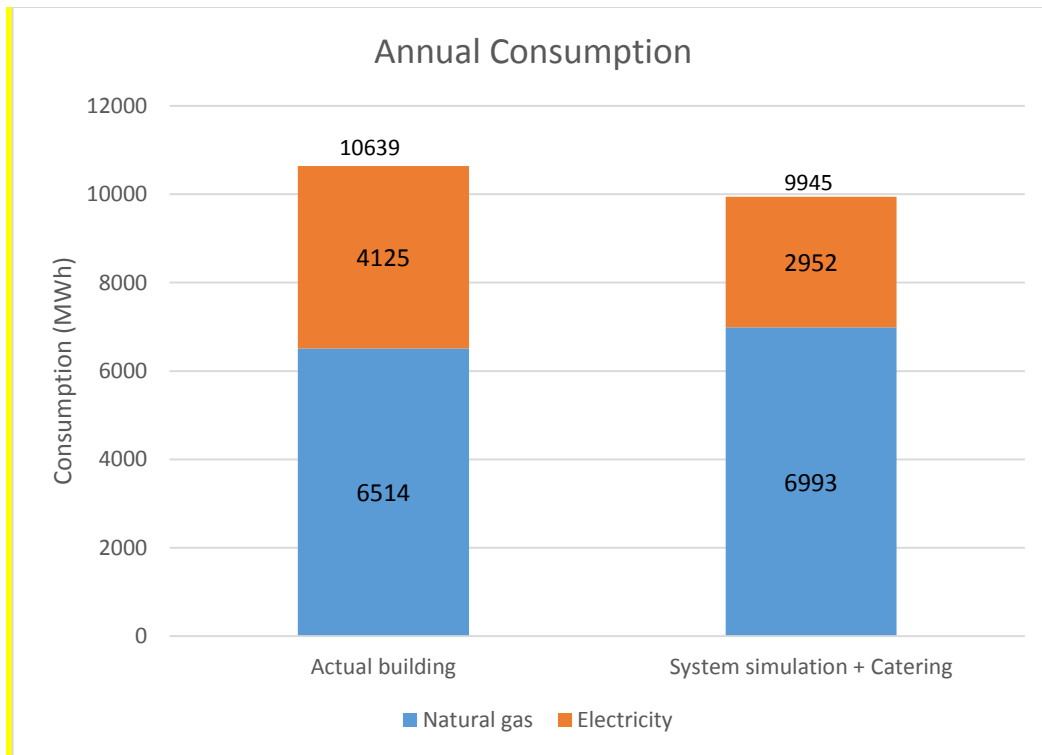

Figure 4.16: Breakdown of annual energy consumption into natural gas and electricity (Hilton London Heathrow)

While the total energy consumption estimate for the building energy model compares favourably to the actual building consumption. Figure 4.16 shows that the breakdown of the energy consumption into natural gas and electricity for the model compared to the actual building consumption presents sizable discrepancies. The percentage difference between the natural gas consumption of the building model and actual building data is approximately 7% overestimation. Additionally, the percentage difference between the building model annual electricity consumption is higher with a 28% underestimation. These differences in the energy breakdown comparison can be partly attributed to the dynamic input data, such as the recent trend in the UK weather having warmer and longer summer, consequently increasing the cooling energy requirement and electricity consumption whilst reducing heating loads which is reflected in the actual building data and not in the building model that uses normalised weather data. Moreover, other dynamic factors

that impact the performance gap between building energy model and operational building such as, the manner of building operation can have a considerable effect on the observed difference in the energy consumption comparison. For instance, from the site visit to the case study hotel during data collection, it was gathered that the hotel building had several issues related to the building's operations in the recent past where instances of simultaneous heating and cooling were observed. Hence, the building energy consumption data provided reflects these operational challenges which cannot be easily factored into the energy model estimations. Besides, it is imperative that the building is operated as designed to ensure energy model estimations compare favourably to actual building data.

Furthermore, the varied result observed in the comparison of energy consumption breakdown for the Hilton Reading hotel (in section 4.41) and Hilton Heathrow Airport T4 hotel in this section further highlight the difficulty in adequately evaluating the energy consumption of existing hotel buildings due to several unique and diverse factors such as building operation and management. However, the energy estimation validation can generally be improved by evaluating the breakdown of actual building consumption into individual end use via submetering which is not available for the case study buildings in this thesis. The evaluation of the building energy end use breakdown can provide a clearer understanding of which of the energy consumption component/end-uses directly influence the differences between actual building energy consumption and building model. This can also provide an indication of additional unregulated building energy consumption that should be accounted in building energy models of hotels.

Figure 4.17 to 4.19 presents the results of the baseline building energy model for Hilton London Gatwick Airport hotel. Figures 4.17 and 4.18 show the 2D and 3D model of the building developed in the 3D modeller component of the simulation software for Hilton London Gatwick Airport hotel.

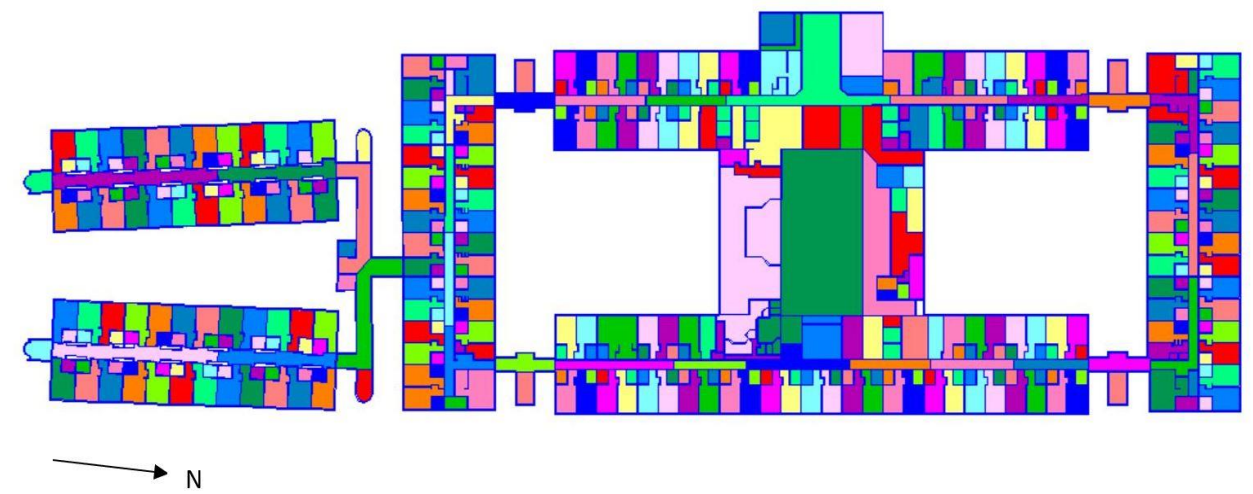
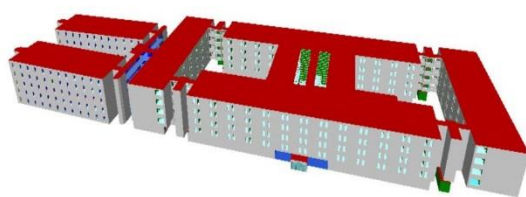
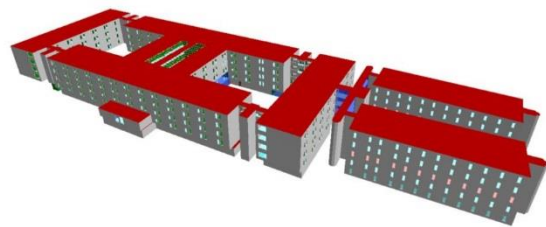

Figure 4.17: Typical floor plan showing floor usage and allocation of zones (Hilton London Gatwick Airport hotel)

The different colour codes shown in Figure 4.17 represent the categorisation of the building into several zones based on their distinct internal condition and usage.



(a) Front view



(b) Rear view

Figure 4.18: TAS 3D model of the building (Hilton London Gatwick Airport hotel)

The TBD module of the software was populated appropriately and simulated to reflect the characteristics of the building operating without a CHP (base model). Subsequently, the simulated TBD file was coupled to the systems and plant modelling module of the software to estimate the energy performance results of the building. Typical results which include reports of annual and

monthly energy consumption and demand are presented. The energy consumption estimate comprises heating, cooling, auxiliary lighting and equipment energy use.

Figure 7.19 illustrate the energy consumption result of the building energy model obtained via plant/systems simulation and augmented with catering energy use. From the figure, it is observed that the estimated total energy consumption of the building simulation model is comparatively lower than that of the actual building consumption with a percentage difference of -5%, indicating an underestimation. Building simulation models cannot completely replicate real building operation, even when the building fabric and internal condition parameters are carefully selected. The discrepancy is associated with the dynamic nature of some of the simulation input data such as weather, occupant behaviour and building operation/management which are difficult to replicate, hence errors cannot be totally eliminated. Moreover, building simulation models use typical weather data for a single year (Holmes and Hecker, 2007) like the TRY weather data used in this case study.

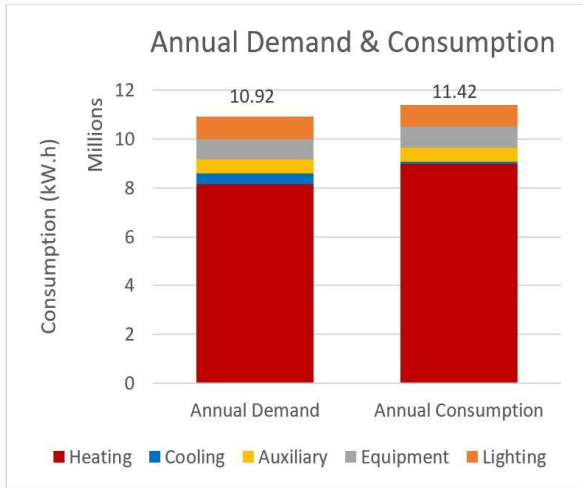

(a) Building model result showing annual demand and consumption

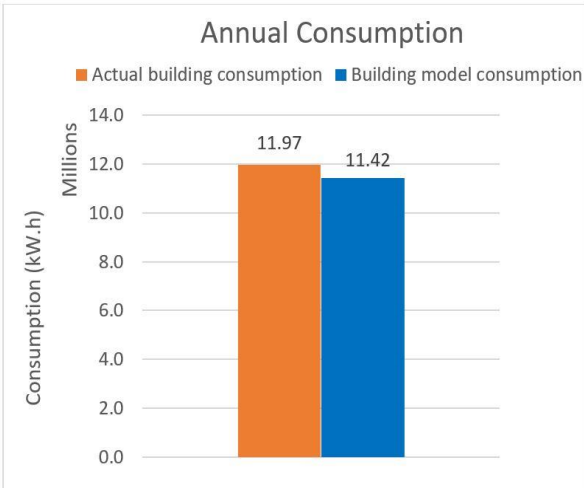

(b) Annual building model result vs. Actual building consumption

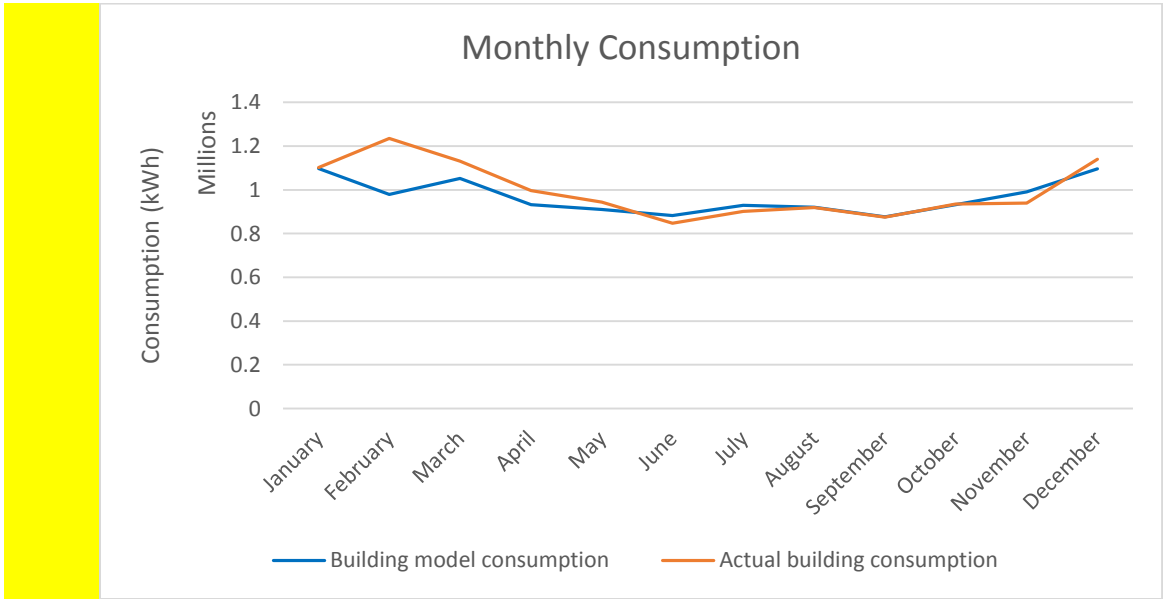

(c) Monthly building model result vs. Actual building consumption

Figure 4.19: Showing building performance result

4.5 Summary and Conclusion

The study of the estimation and validation of energy consumption in an existing UK hotel building via a dynamic simulation model highlighted the known existence of the performance gap between estimated energy consumption and actual building energy consumption in commercial buildings. In addition, since many studies were focused on improving the performance estimation in mostly office buildings, this chapter presents a method of improving the estimation of actual energy consumption in an existing non-domestic structures using three different hotel buildings as case studies.

The results of the case study hotel buildings show that the use of energy models that are not strictly subjected to building regulations or NCM methodologies/databases and which also account for some unregulated energy use such as catering, which is significant in a hotel, can considerably improve actual building consumption estimates. For this case studies, overall energy consumption estimate which were within 5% to 11% accuracy compared to the actual building consumption data was obtained. Moreover, the result also demonstrated that such a model can produce energy consumption estimates that are up to 20% more accurate than building regulation compliance models. The result of this study provides an indication of possible unregulated energy use that can be estimated to aid in the reduction of performance gaps for hotel buildings that have restaurants or high catering demands. However, the study is limited in its use of benchmark energy estimates to account for catering energy use and in the use of a limited number of case study buildings to validate performance gap reduction. Therefore, further studies should be done in other hotels in the region to validate the proposed model. Additionally, building energy consumption comparison and validation with total energy consumption can be improved by evaluation of the breakdown of actual building consumption into individual end use, as this can deliver a better understanding of

the energy consumption component/end-uses that directly influence the differences between actual building energy consumption and building model.

4.6 Recommendations

The encouraging results also demonstrate that even more accurate predictions can be obtained if more unregulated building energy use such as lifts, small power loads and servers can be accounted for and factored into the model. Additionally, the results demonstrate that designers that do not have access to actual building energy data for validation can produce improved energy performance estimates with greater confidence by using the suggested approach in this study, particularly if more of the unregulated energy use consumption estimates are accounted for in the energy model. Possible limitations to designers using this approach relate to the accuracy of input data and assumptions (for example, occupancy density, hours of occupancy and temperature set point) since design assumptions might differ from actual building usage.

Chapter 5: Impact of Extraction Fans in the Cavity of the East and West

Double Skin Facade on the Thermal and Energy Performance of Hilton

London Heathrow Airport Terminal 4

5.1 Introduction

The advantages of DSF systems, ranging from their aesthetic architectural benefits of increased transparency, acoustic benefits and ability to decrease the heating demand of the internal environment while serving as a protection against the external environment, have increased their popularity, especially in Europe, since the mid-1980s (Poirazis, 2004; Chou *et al.*, 2009). The main feature of the DSF which provides it with this advantage is the cavity between the external and internal glazed skin that acts as an insulating barrier against the undesirable effects of the external microclimatic condition. This cavity (air gap or corridor) can be naturally or mechanically ventilated and thus the attributes of the cavity space such as its ventilation or shading strategies determine the performance of the DSF (Poirazis, 2004; Ghaffarianhoseini *et al.*, 2016). The application and role of DSF in a building's fabric is complicated as it affects different building parameters that usually interact with each other (such as ventilation, natural lighting, internal air quality, thermal comfort and energy use) and hence, appropriate consideration must be given to its design to ensure their possible advantages are not negated (Poirazis, 2004).

The DSF system in this case study hotel building adjoins a large central atrium to the east and west, so the aesthetic benefit of multilevel glass façade, which permits increased transparency and unimpeded daylighting, further enhances the atrium. The application of a modern day atrium in commercial builds (especially hotels, shopping malls and offices) became common during the late 1950s and early 1960s (Abdullah, 2007). The aesthetic value of atria as a space organizer with

traditional environmental merits allowing sufficient natural lighting, passive cooling and heating are now being exploited in temperate climate building designs in response to high building energy consumption and energy security challenges (Abdullah, 2007). Atria have the potential to improve the thermal comfort of occupants by enabling solar radiation, natural heating and cooling, which can contribute to reducing lighting, heating and cooling energy demand (Jaberansari & Elkadi, 2016). It is a common general assumption that atria automatically reduce the overall energy consumption of a building, but this is a misconception if they are not designed appropriately especially as the thermal behaviour of atria remains difficult to predict (Abdullah, 2007; Aldawoud & Clark, 2008).

This case study evaluates how the effect of extraction fans installed in the east and west DSF adjoining a central atrium impacts the thermal condition of the atrium and consequently the impact on the overall energy consumption of the hotel building. The study was necessitated due to the challenge of a prevailing high temperature identified in the cavity of the DSF, resulting in a high temperature in the atrium, thus increasing the cooling demand. Therefore, the possibility of installing extraction fans as a DSF ventilation strategy is evaluated by this study as an alternative to increasing the capacity of the chillers, as it has a significant impact of the total energy consumption of the building. The study considers the holistic effect of the ventilation of the DSF cavity on the overall energy consumption. It also contributes to the existing body of knowledge, as most studies in this subject use case study investigation of either a commercial office building or prototype building; or computational fluid dynamics modelling of the DSF cavity alone. Additionally, the study ensures that possible marginal increase in energy consumption resulting from the introduction of the extraction fans is neutralised by presenting the optimum operational schedule for the fans. Moreover, the attributes of this case study hotel, which includes a large

central atrium enclosed by DSF to the east and west, justify the need for it to be investigated, especially as the effect of both features on the energy and thermal performance is difficult to evaluate.

5.2 Building Description

The description of the case study building (Hilton London Heathrow Airport Terminal 4 Hotel) used for this evaluation is provided in preceding section 4.2.2.

5.3 Study Method

Sections 3.7-3.10 of this thesis present the general methodology and core processes used to create the holistic model of this case study building on the dynamic simulation software TAS; some information peculiar to this case study is presented in this section.

The process that was employed to achieve the stipulated aim with the case study building can be categorised into two distinct stages. The first stage involves estimating the energy consumption of the building by developing a holistic model reflecting the building's fabric, systems and thermal performance. The predicted energy consumption is validated by comparing against actual consumption data. These data are collected by survey of the case study building to enable verification of available data such as building fabric data (e.g. walls and windows), occupancy information to ensure simulation assumptions are realistic, building usage to ensure zone grouping is as shown on the architectural plan and HVAC system characteristics. The second stage involves the integration of the extraction fans into the model to evaluate their impact.

5.3.1 3D modelling

The AutoCAD drawing files provided the main data used for the 3D modelling. The building drawings comprise floor plans and layout for the first to fifth floor and the roof plan. As highlighted

in section 3.7, the drawings provide necessary data on the building geometry, layout and functional use of the various zones of the building. Figure 4.2 in preceding section 4.2.2 show the typical AutoCAD architectural floor plan of the case study building

5.3.2 Simulation process

The TAS building modeller module of the software suite is the core component of the software and the building simulation process because the data and information describing the buildings characteristics and operation are specified at this point. Therefore, judicious selection of modelling parameters is essential. The required simulation parameters of calendar, weather data, building elements, schedules, zones, internal condition and aperture types were populated to perform the thermal performance of the building.

Figure 3.3 in section 3.7 illustrates the thermal simulation process employed. Tables 4.5 – 4.7 in section 4.3.2 present the modelling parameters and assumptions base the case study building's characteristics for Hilton London Heathrow Airport Terminal 4 hotel. Additionally, Figure 5.1 shows summary of the case study process:

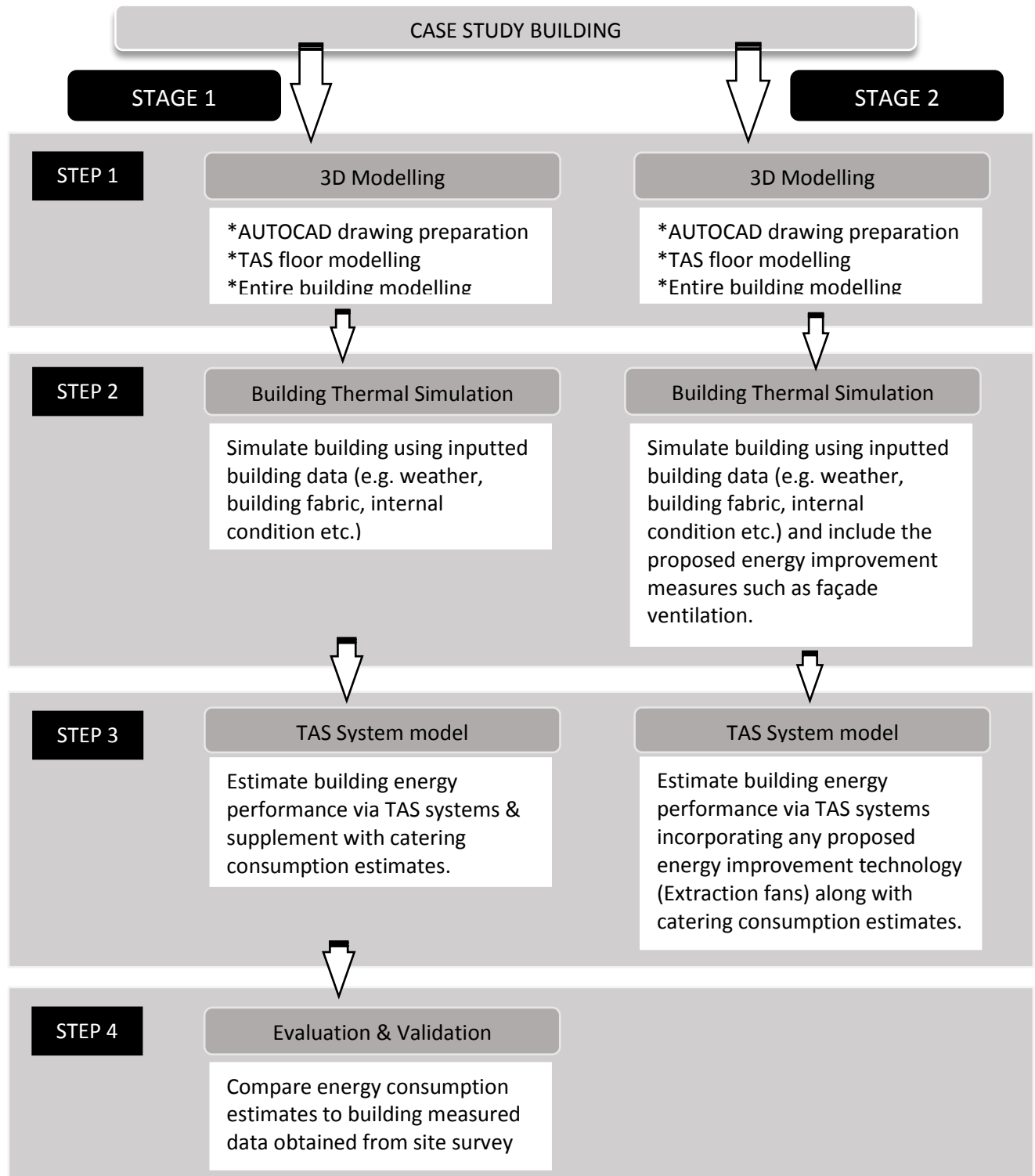

Figure 5.1: Summary of case study methodology

5.4 Results and Discussion of Results

The results and discussion of the case study hotel building are presented in this section. Preceding section 4.4.2 of this thesis presented the results and discussion of results for the first stage of this study which entails estimation and validation of the case study building the energy consumption (that is, the base model without extraction fans).

The next phase of the analysis involves the simulation of the case study building with extraction fans installed in the east and west facing DSF adjoining the central atrium. The result and analysis of this simulation are presented in Figures 5.2 to 5.11:

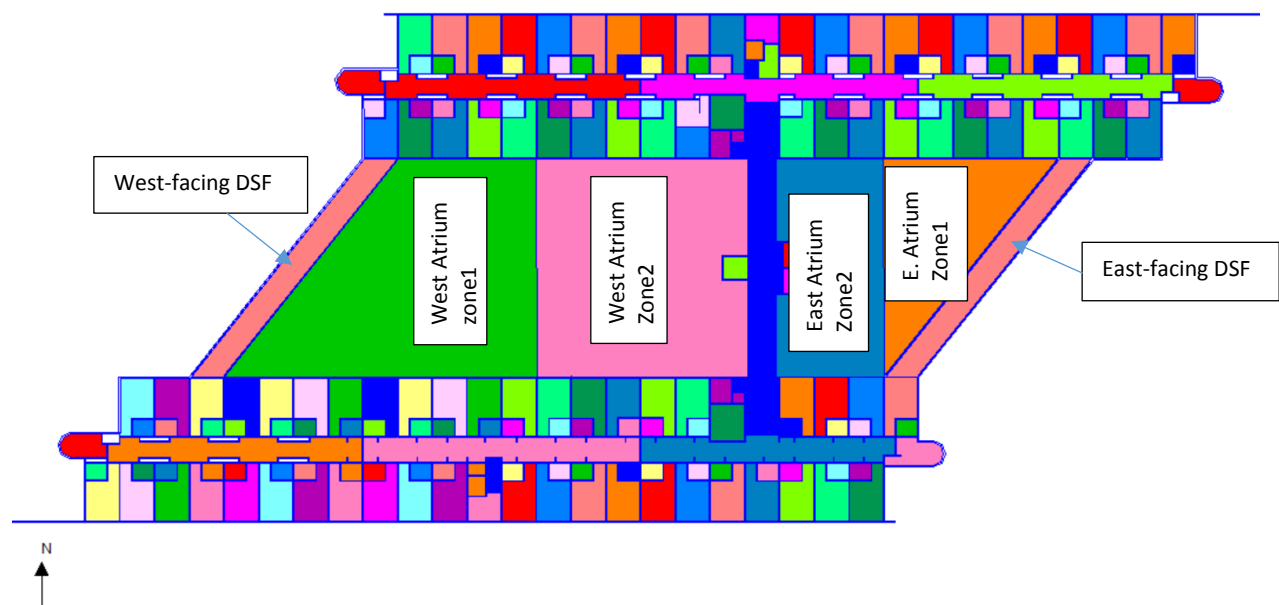

Figure 5.2: Zoning of atrium and adjoining double skin façade.

Figure 5.2 shows the different zoning of the central atrium space and façade along with the zones' respective direction or orientation (that is, west or east). The central atrium space to the east and west is sub-divided in zones 1 and 2 with a null line because of the size of the space. The division

with null lines does not act as a wall or barrier in the simulation. It is only employed to divide large spaces into smaller units to facilitate the analysis process and improve the output.

The internal condition applied to the west and east DSF façade cavity space is ‘unoccupied unconditioned’ which implies that no cooling or heating is used in that space, whereas the main atrium space is simulated as internal circulation space where heating or cooling is applied.

The results of the simulation of the baseline model with an unventilated DSF cavity showing the difference in temperature between the east and west façade space and the main central atrium are presented in Figures 5.3 to 5.5 below. The temperature result analysis is presented to provide an understanding of the prevailing temperature in the façade cavity and its influence on the operating temperature of the atrium space:

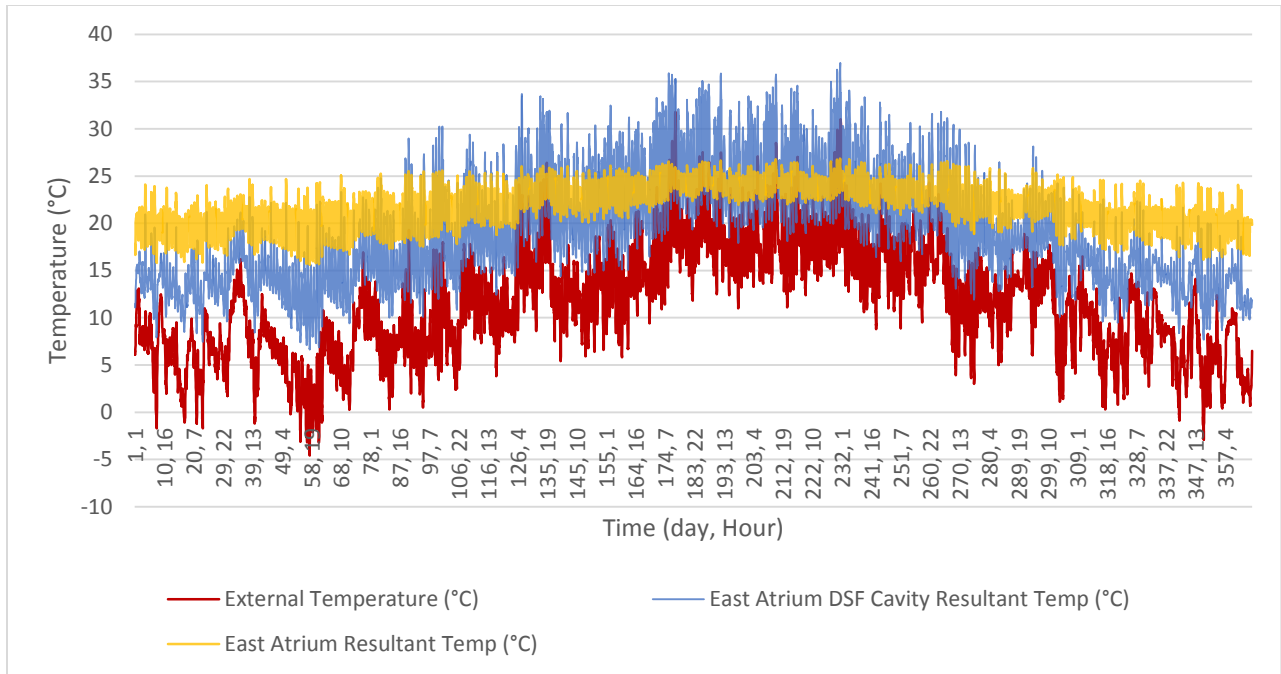

(a) External temperature, East atrium DSF cavity and East atrium resultant temperature vs time (day, hour)

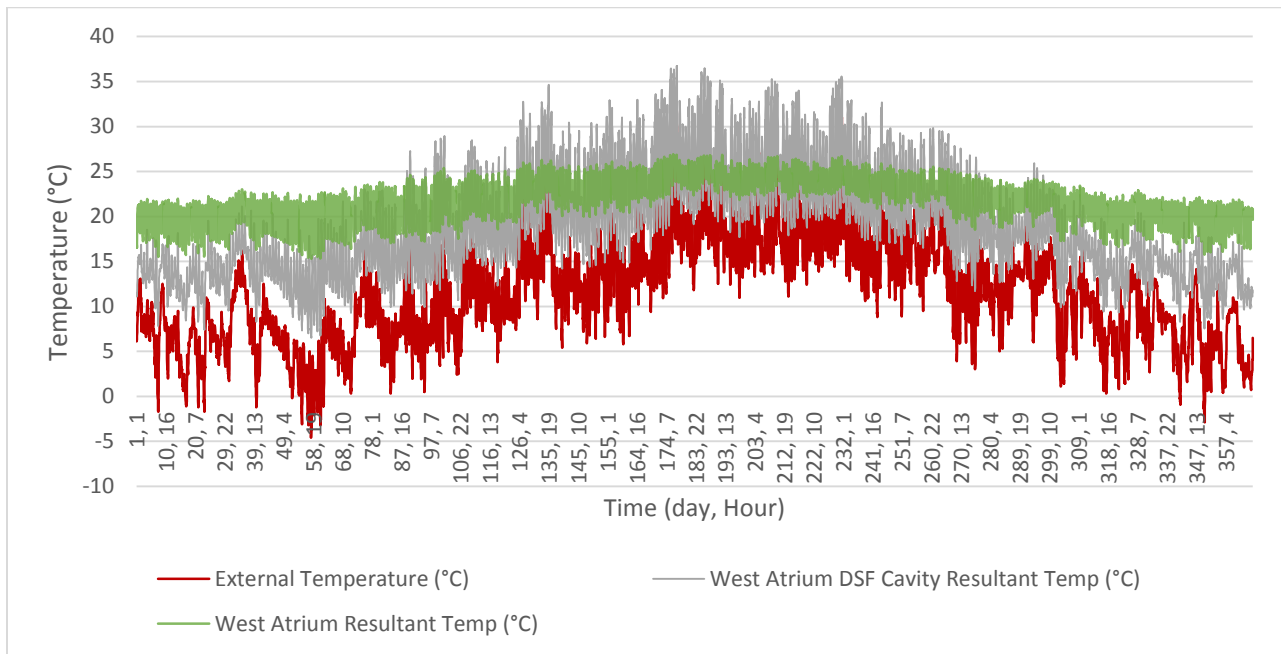

(b) External temperature, West atrium DSF cavity and West atrium resultant temperature vs time (day, hour)

Figure 5.3: External temperature, DSF cavity temperature and Atrium temperature result without extraction fans vs. time (day, hour) throughout the year.

A brief description of the lines on the graph presented in Figure 5.3 is given to aid in the comprehension of the subsequent critical analysis of the figures.

The [External Temperature (°C)] line on the graphs simply shows the value of the external temperature of the CIBSE TRY weather data file used by dynamic simulation software for the building simulation (the weather data file contains hourly temperature across the year).

The [West Atrium DSF Cavity Resultant Temp. (°C)] line on the graph shows the simulation result for the prevailing resultant temperature in the cavity of the west atrium DSF.

The [East Atrium DSF Cavity Resultant Temp. (°C)] line on the graph shows the simulation result for the prevailing resultant temperature in the cavity of the east atrium DSF.

The [West Atrium Resultant Temp. (°C)] line on the graph shows the simulation result for the prevailing resultant temperature in the west atrium space.

The [East Atrium Resultant Temp. (°C)] line on the graph shows the simulation result for the prevailing resultant temperature in the west atrium space.

From Figure 5.3, showing the temperature result for the DSF cavity, the adjoining atrium space and external temperature without a DSF cavity extraction fan, it can be observed that the prevailing resultant temperature in both the east and west DSF cavity is largely significantly higher during the summer period than the prevailing resultant temperature in the adjoining atrium space. Also, the DSF cavity temperature is generally lower than that observed in the atrium space during the winter season. This considerable temperature difference can have adverse effects on the thermal comfort of the atrium space. Figures 5.4 and 5.5 present further analysis of the observed temperature difference.

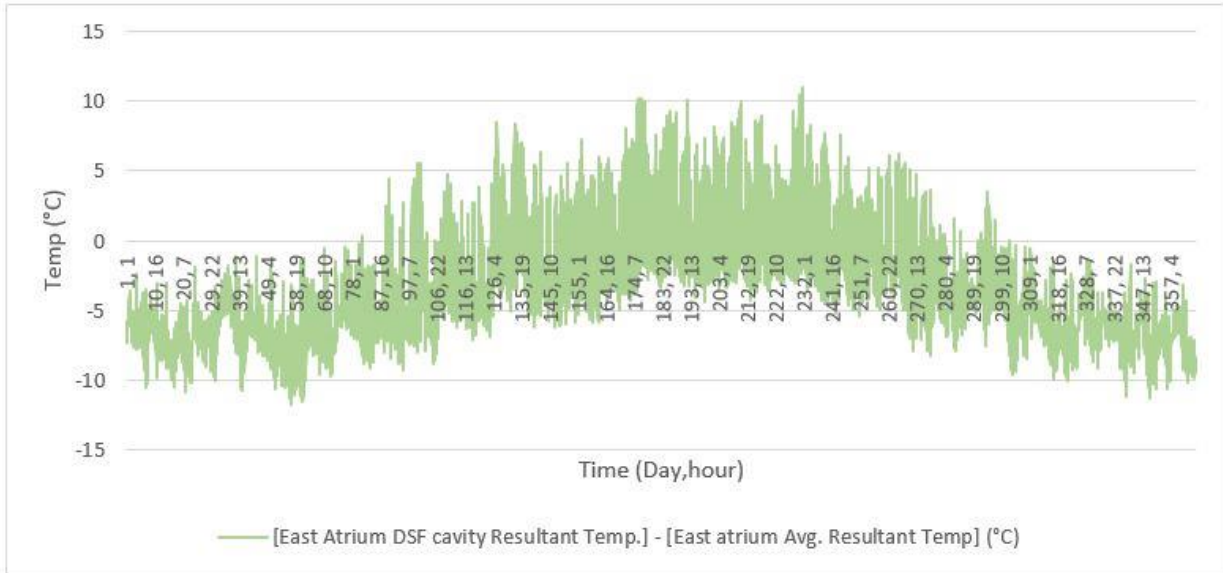

Figure 5.4: Difference in resultant temperature between the east DSF cavity and adjoining central atrium (without extract fan)

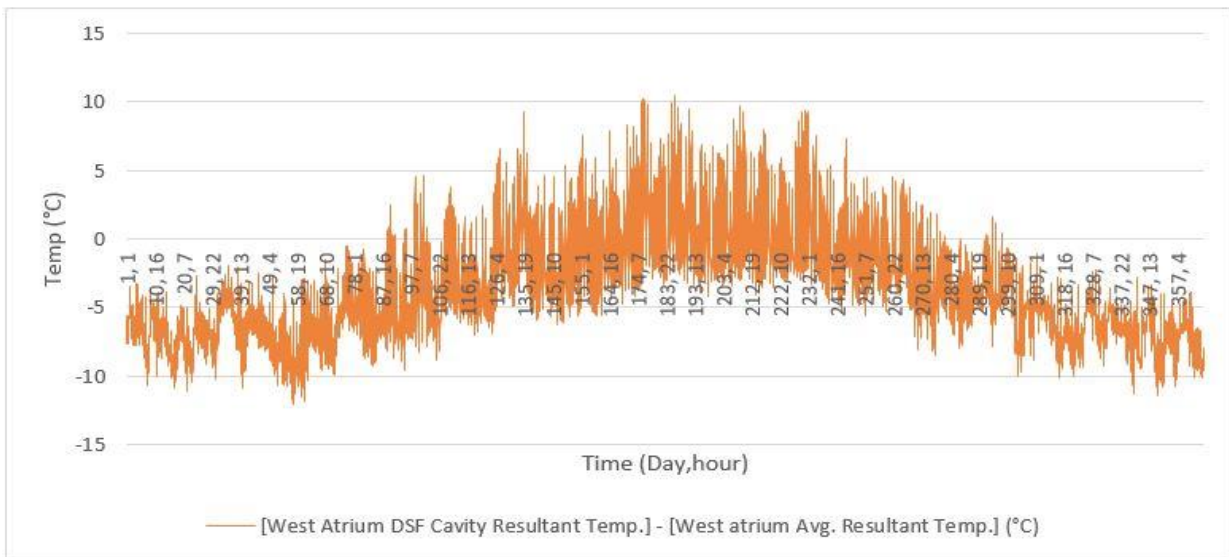

Figure 5.5: Difference in the resultant temperature between the west DSF cavity and adjoining central atrium (without an extract fan)

A brief description of the lines on the graph presented in Figures 5.4 and 5.5 is given to aid in the comprehension of the subsequent critical analysis of the figures.

The [East Atrium DSF cavity resultant temp. – East Atrium avg. resultant temp. (°C)] line on the graph shows the plot of the value of the (East Atrium façade resultant temperature) subtracted from

the (East Atrium average resultant temperature). Hence, a negative (-) value implies that the temperature of the (East Atrium façade resultant temperature) is less than that of the (East Atrium average resultant temperature) and a positive (+) value implies the opposite.

The [West Atrium DSF cavity resultant temp. – West Atrium avg. resultant temp. (°C)] line on the graph shows the plot of the value of the (West Atrium façade resultant temperature) subtracted from the (West Atrium average resultant temperature). Therefore, a negative (-) value implies that the temperature of the (West Atrium façade resultant temperature) is less than that of the (West Atrium average resultant temperature) and a positive (+) value implies the opposite.

From a critical analysis of Figures 5.4 and 5.5, it can be observed that the temperature difference between the atrium's DSF façade cavity and the central atrium is quite significant especially at the peak of the cooling and heating periods. A temperature difference of between 10 °C to 11 °C is observed at the peak of the cooling period in June and July. A similar trend is observed around the peak of the heating period, between October and February, where a temperature difference of -10 °C to -12 °C was obtained. The considerable temperature difference observed from the simulation can significantly affect the heating and cooling loads of the central atrium space especially in warmer weather scenarios, leading to increased risk of overheating and reduction in occupants' thermal comfort.

Since the results across the year have indicated that the internal condition of the DSF cavity has the most impact on the atrium space during the peak of the cooling and heating periods, Figures 5.6 and 5.7 present the result of a typical hot summer day and cold winter day for clearer understanding and insight.

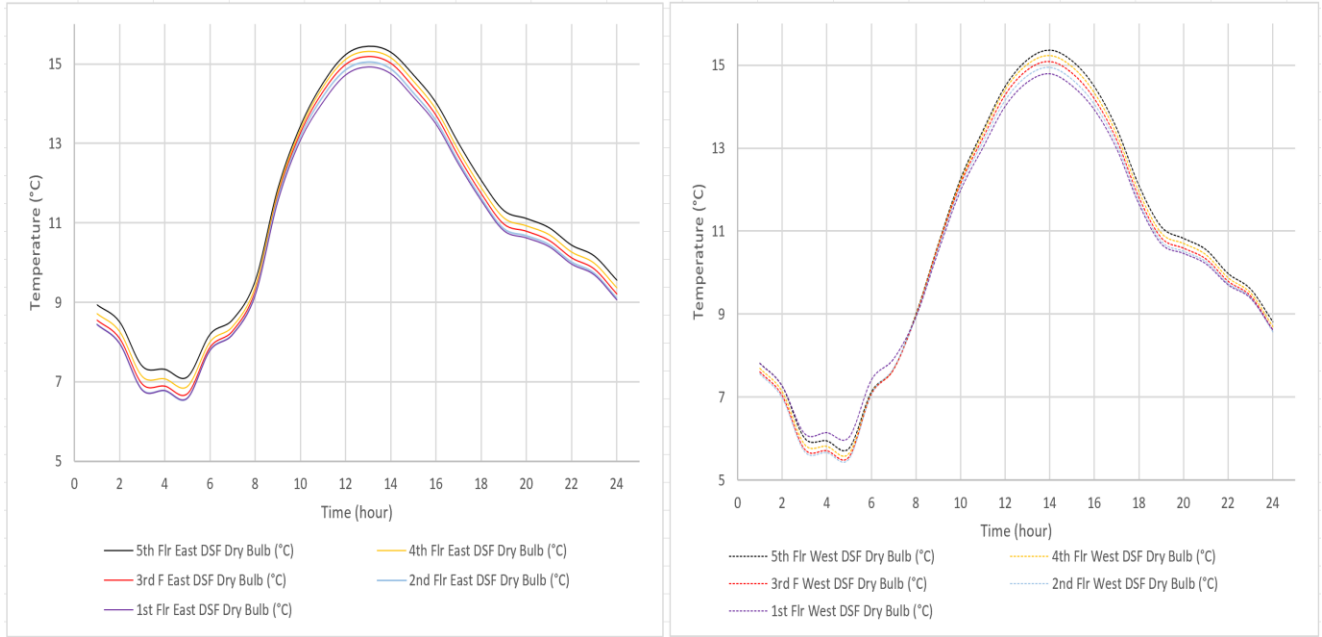

(a) East DSF cavity air temperature result for a Cold mostly cloudy day

(b) West DSF cavity air temperature result for a Cold mostly cloudy day

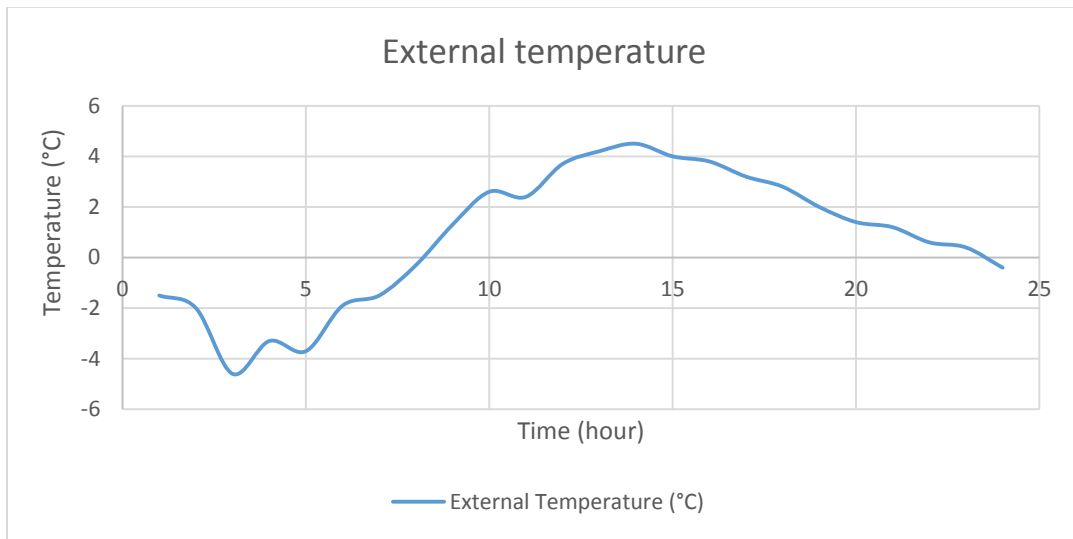

(c) External temperature of the CIBSE TRY weather data for the cold mostly cloudy day

Figure 5.6: DSF Cavity simulation result for a typical cold mostly cloudy day

Figure 5.6 illustrates the simulation result for a typical cold day to demonstrate the effect of the cavity. The DSF cavity space was vertically divided into zones to show the stratification of air

(stack effect) possible in such a space. Particularly, since in reality the whole volume of air in the DSF cavity is not going to be homogenous, rather it is usually arranged in layers with warmer, less dense air at the top of the stack. Hence, the DSF cavity was vertically divided into five zones corresponding to the different floor levels and the temperature results at these floors are presented. From figure 5.6 it can be observed that the air temperature of the East and West DSF cavity is significantly higher in relation to the cold external temperature, especially during the afternoon and evening periods. Maximum temperature of over 15 °C can be observed in the afternoon which is up to 10 °C higher than the maximum external temperature for the day. Moreover, the relatively warmer DSF cavity is favourable during the heating season as it contributes towards reducing the heating load of the adjoining atrium central atrium.

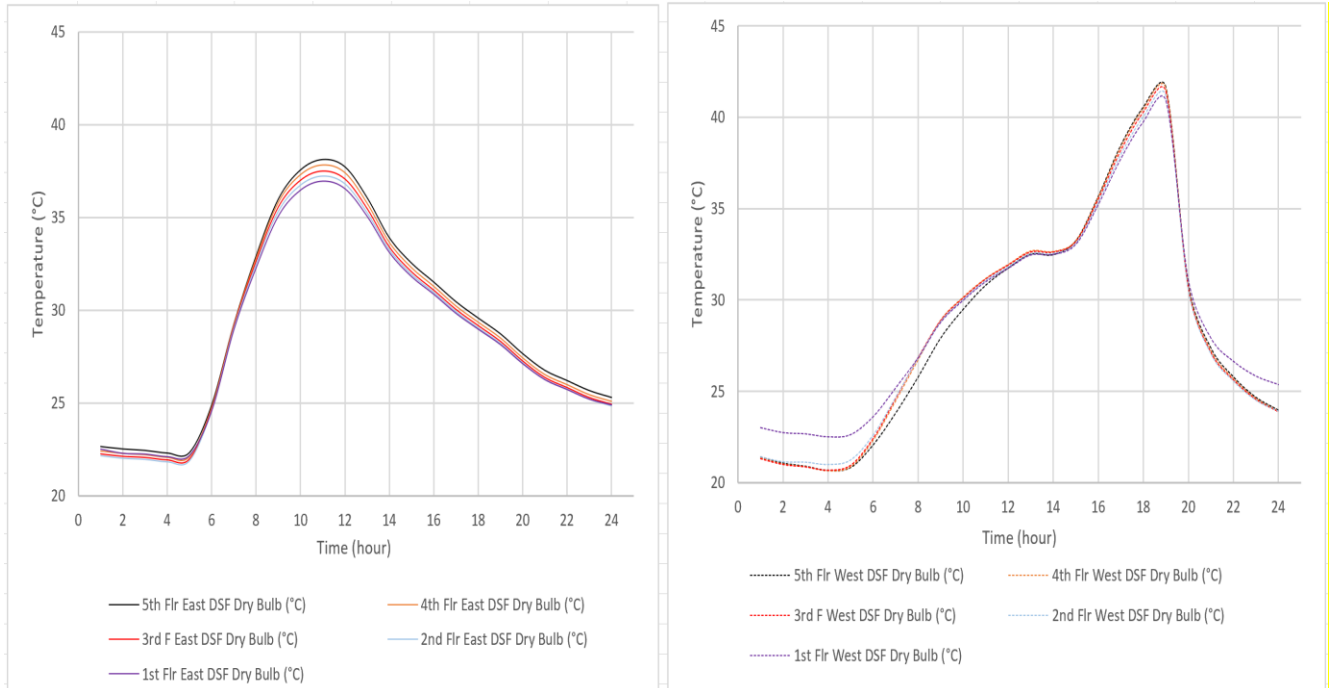

(a) East DSF cavity air temperature result for a Hot sunny day

(b) West DSF cavity air temperature result for a Hot sunny day

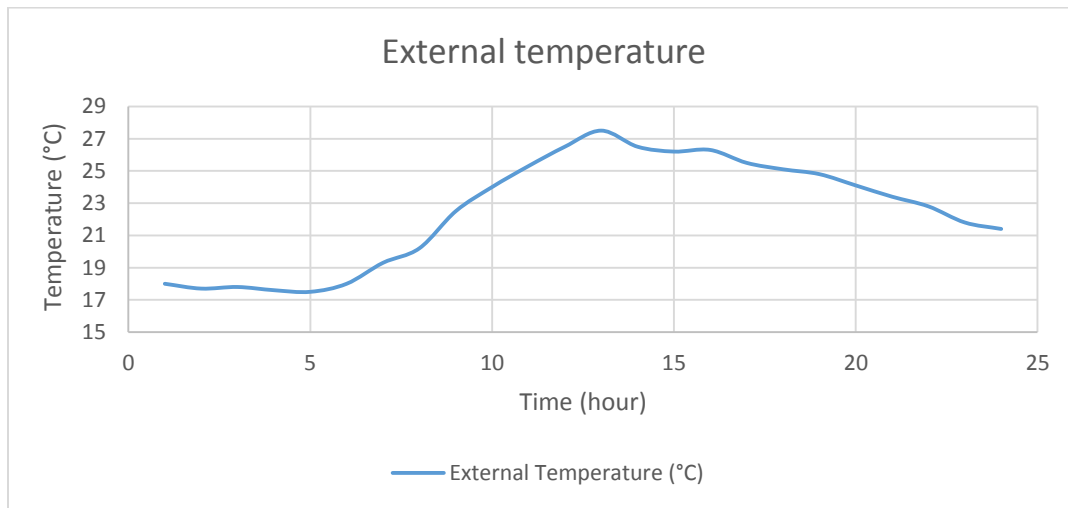

(c) External temperature of the CIBSE TRY weather data for the Hot sunny day

Figure 5.7: DSF Cavity simulation result for a typical Hot sunny day

From Figure 5.7 showing the simulation result for a typical hot sunny day, it can be noted that the DSF cavity temperatures in both the East and West DSF are substantially higher than the prevailing external temperature. Maximum temperature of over 37°C can be observed before noon in the East

DSF cavity which is up to 10 °C higher than the maximum external temperature for the day. Additionally, in the West DSF cavity even higher temperature can be observed with a maximum temperature of over 41°C in the evening which is up to 13 °C higher than the maximum external temperature for the day. Consequently, the prevailing high temperatures noted in the DSF cavity during a typical sunny summer day can have adverse effect on the internal environment of the adjoining central atrium space by increasing the cooling load and resulting to increased risk of overheating.

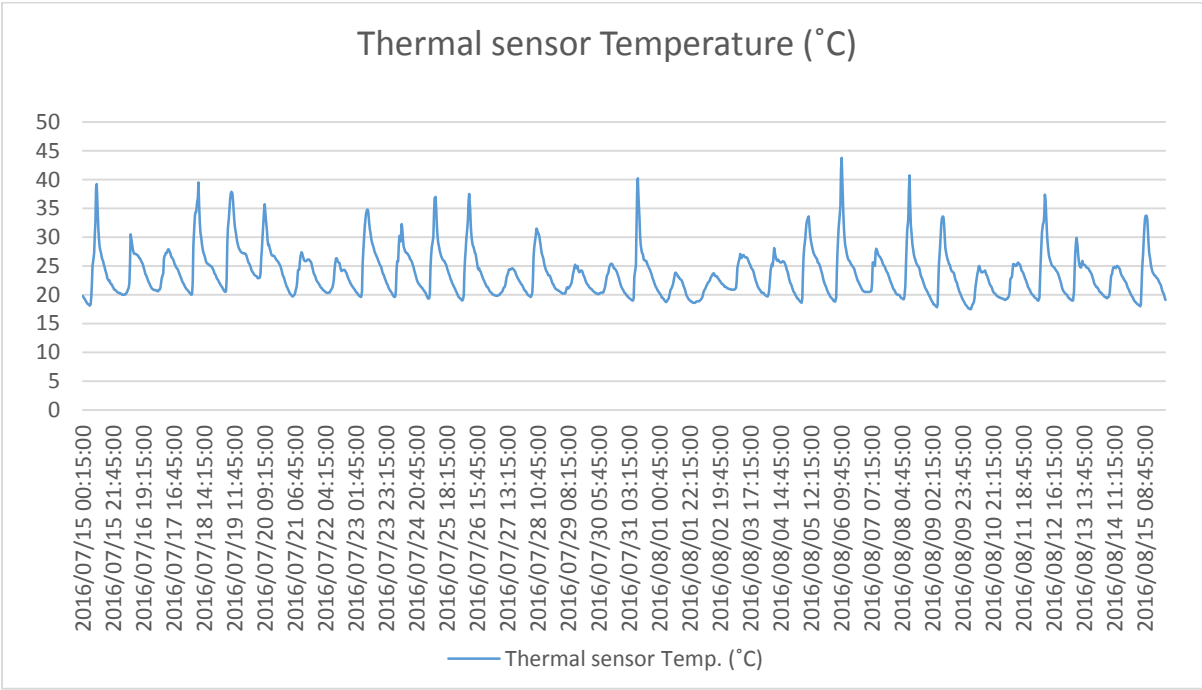

Figure 5.8: Temperature of thermal sensor installed in the east facing DSF cavity

Figure 5.8 presents the temperature values for a typical summer month period obtained from a weather station installed in the cavity of the DSF. The weather station records temperature, pressure, humidity and noise level. From the figure, it can be noted that the temperature readings of the DSF cavity is significantly high, with maximum temperatures ranging from between 39 °C to 44 °C on some hot summer days. This justifies the significant temperature difference between

the façade cavity and the central atrium observed from the simulation result presented in Figures 5.4 and 5.5:

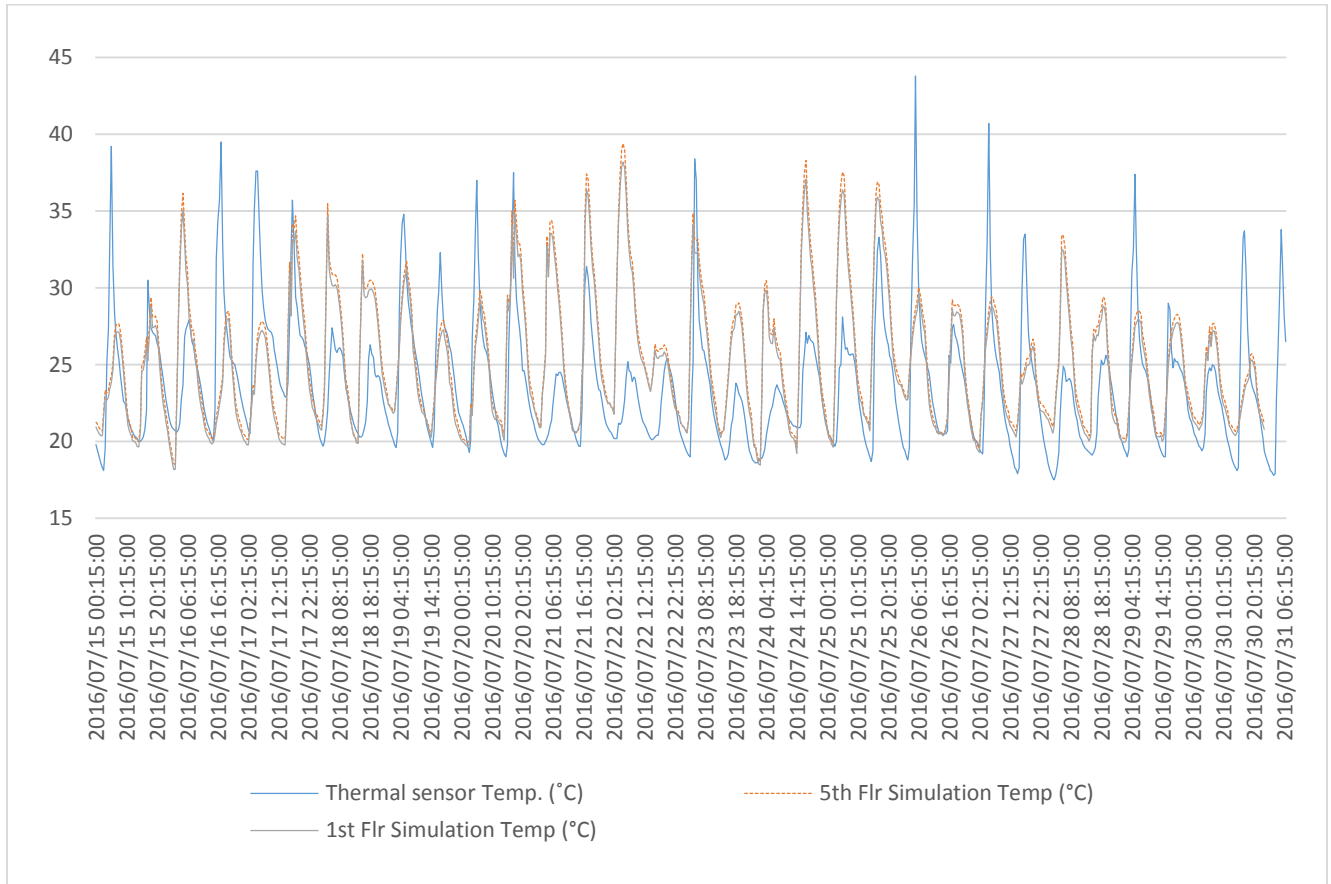
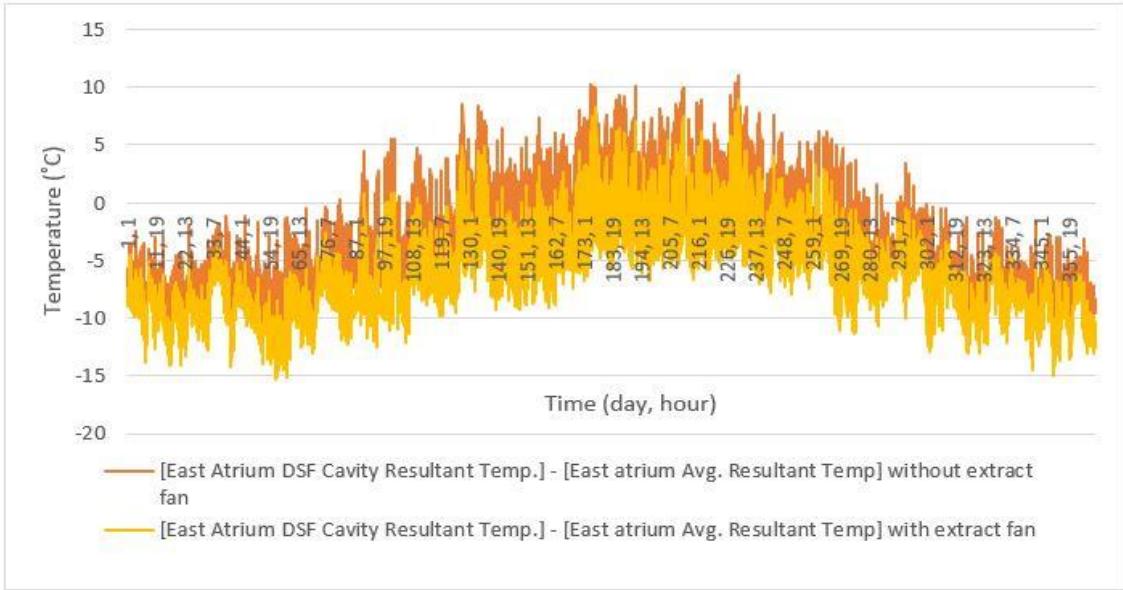

Figure 5.9: DSF façade thermal sensor temperature reading vs DSF façade simulation temperature result

Since the collection of thermal sensors reading was only possible for a month before the installation of the extract fans. Figure 5.9 presents the base model DSF cavity air temperature results compared to that of the installed thermal sensor for the month of July. The figure indicated that the simulation results compared favourably in some periods of the month, with both simulation result and measured air temperature highlighting the significant high temperature in the DSF cavity. However, there were generally some sizeable mismatch in the maximum temperature

values of the thermal sensors and the simulation results. This mismatch can be attributed to a number of reasons, such as some modelling assumptions and simplifications in dynamic simulation models for simulating DSF cavity and atrium which have been noted from literature to be onerous and complex to simulate. Moreover, the difference in the dynamic weather data was also responsible for the mismatch, especially as the micro climatic weather pattern for the period of thermal sensor measurement can be different from the simulation weather file which uses typical average weather data. Even though the comparison was made with days corresponding to a similar period of the year (that is, simulation days 196 to 227 corresponding to the month of July).



(a) Showing resultant temperature difference between the East DSF cavity and central atrium (with and without extraction fan)

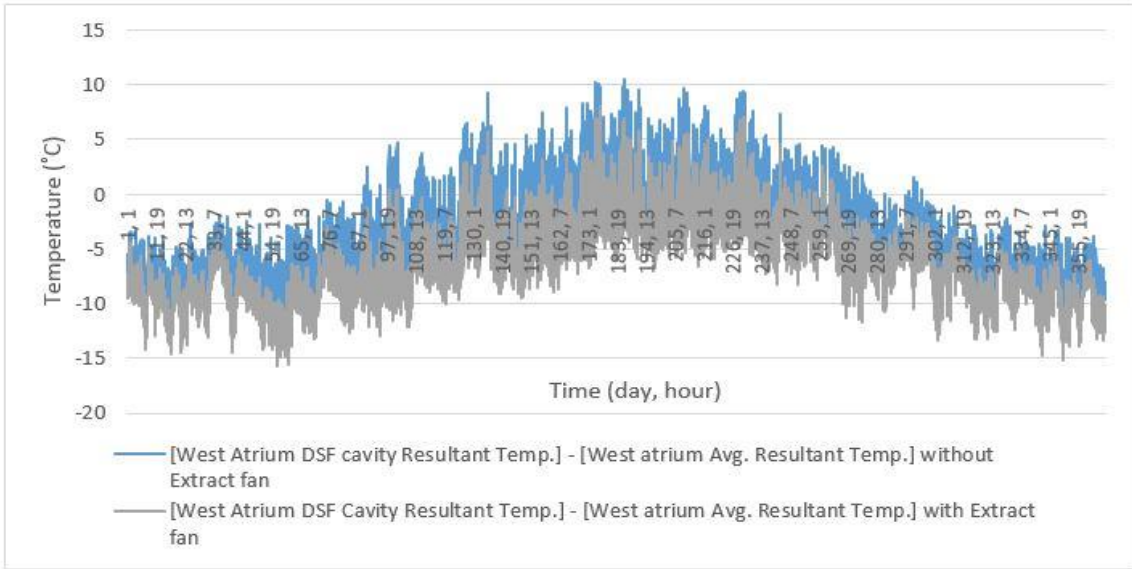

(b) Showing resultant temperature difference between the West DSF cavity and central atrium (with and without extraction fan)

Figure 5.10: Resultant temperature difference between the DSF cavity and central atrium (with and without extraction fan)

From a critical analysis of Figure 5.10 which presents the comparison of resultant temperature difference between the DSF cavity and the central atrium for the model simulation with and without extraction fan, it can be seen that the installation of the extraction fans generally reduces the prevailing temperature in the east and west DSF cavity. Therefore, it considerably reduces the temperature difference between the east and west DSF and the adjoining central atrium across the year. This helps to enhance the internal temperature of the central atrium especially during the summer period, thus reducing the risk of overheating and cooling demand. However, the reduced temperature difference is not favourable during the peak of the heating season as the warmer temperature in the DSF cavity is needed to reduce the heating load.

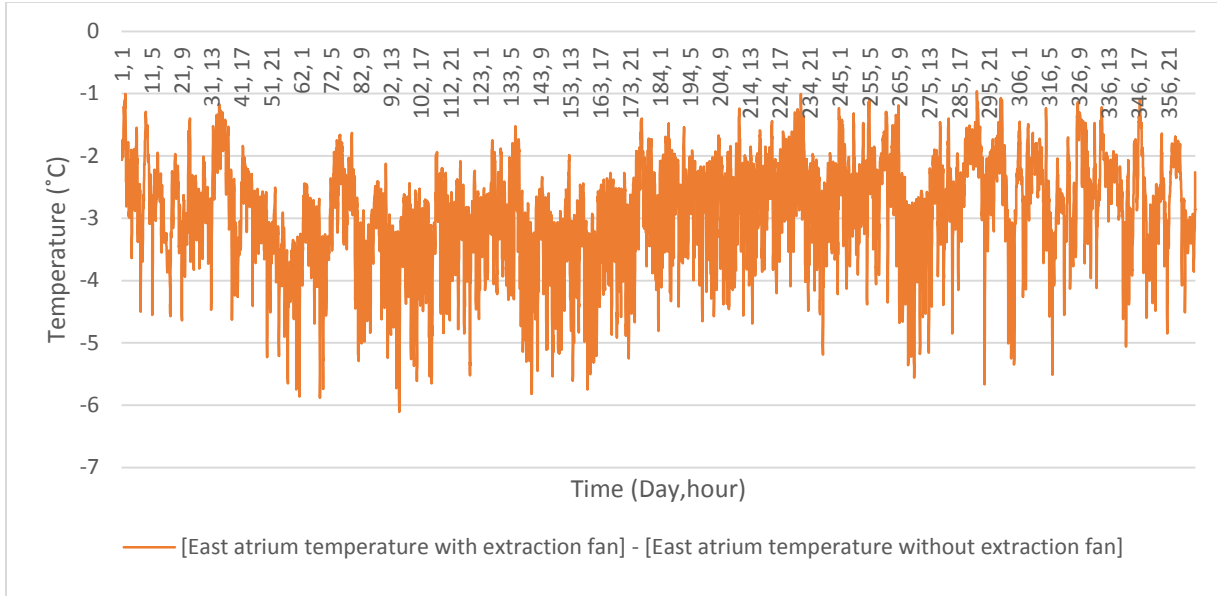

(a) Difference in resultant temperature for the East central atrium space due the effect of the extraction fan

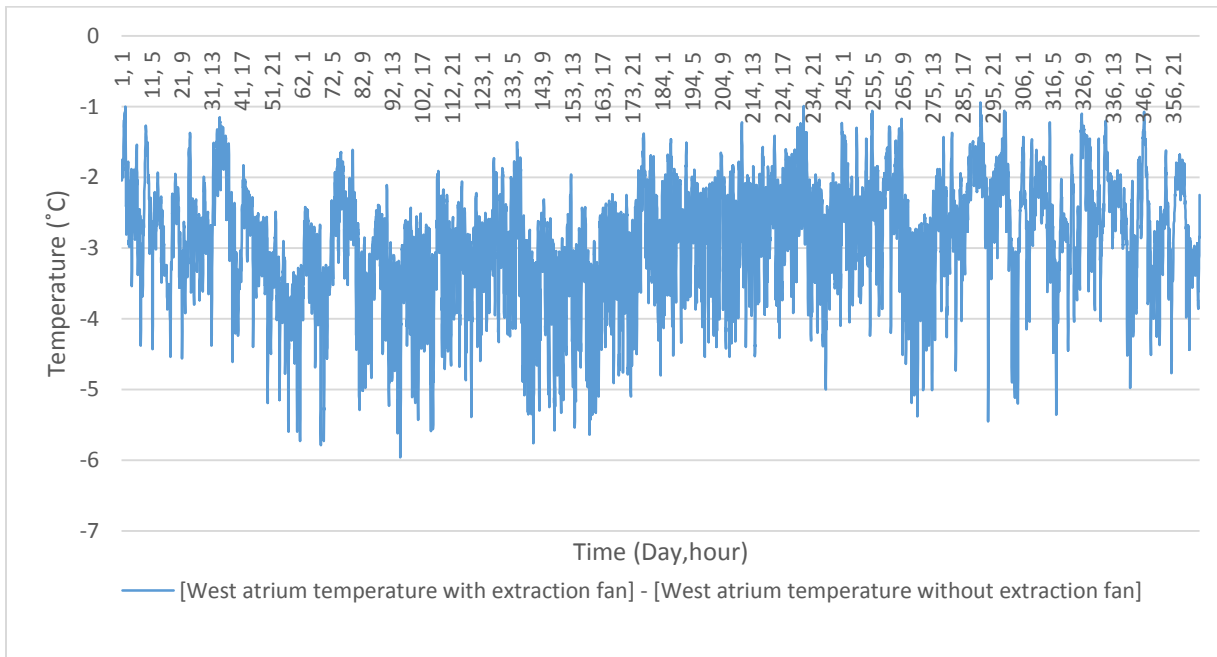

(b) Difference in resultant temperature for the West central atrium space due the effect of the extraction fan

Figure 5.11: The difference in resultant temperature in the central atrium space due to the effect of the extraction fan.

From Figure 5.11, the negative values (-) result obtained from the subtraction of the atrium resultant temperature with an extraction fan from the atrium resultant temperature without an extraction fan in the DSF cavity shows that the extraction fan generally reduces the atrium resultant temperature. Moreover, it can be observed that a temperature reduction of over 5°C in the atrium resultant temperature is achievable during the peak of the summer period due to the effect of the fans. Therefore, the installation of extraction fans in the DSF cavity can improve the perception of temperature in the atrium space, thereby improving occupants' thermal comfort especially during the summer.

The impact of the extraction fans on the overall energy consumption of the hotel building is presented in Figures 5.12 to 5.14:

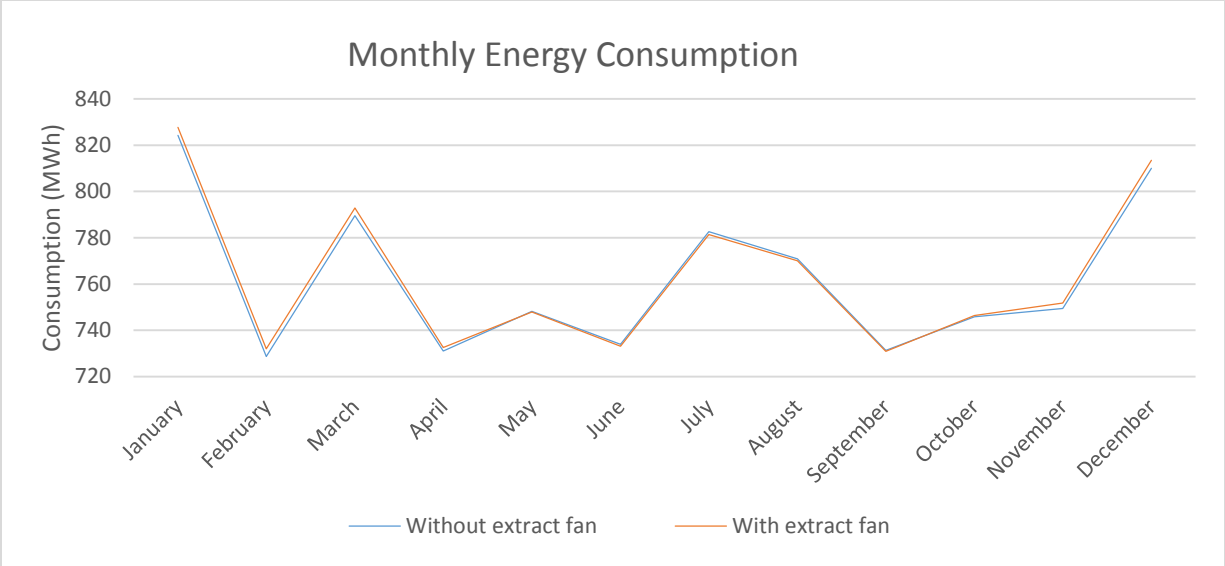

(a) Monthly overall energy consumption result

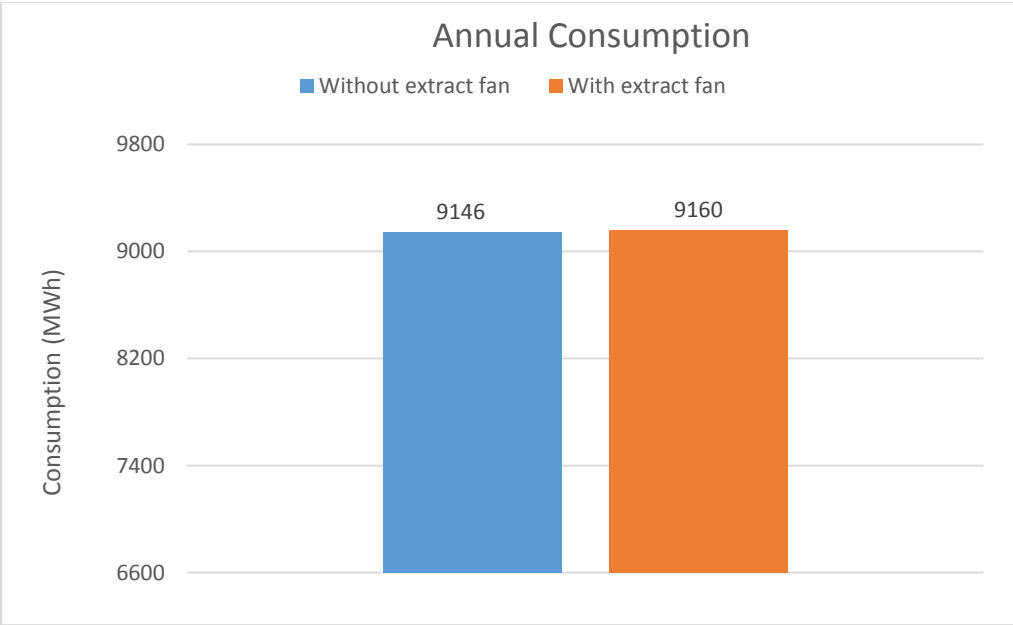

(b) Annual overall energy consumption result

Figure 5.12: Overall energy consumption result for simulation with and without extract fan

Figure 5.12 illustrates the overall energy consumption result for the simulation evaluating the impact of the extraction fans in the DSF cavity adjoining the central atrium compared to the

baseline model without extraction fans. From Figure 5.12(a), it can be observed that the operation of the extraction fan during the winter, spring and autumn season results in a marginal increase in the overall energy consumption when compared to the energy simulation result of the model without the extract fan in operation. Moreover, Figure 5.12(b) shows that there is a marginal increase of 0.2% in the overall energy consumption estimate with the model having the extraction fan in operation throughout the year. Although the impact of the extraction fans on the overall energy consumption is not substantial, it is insightful to analyse the effect of the fans on the components of the energy consumption that they have direct influence on. This is helpful to deduce the optimum operation schedule for the extraction fans. Therefore, the heating and cooling energy consumption results are presented Figure 5.13.

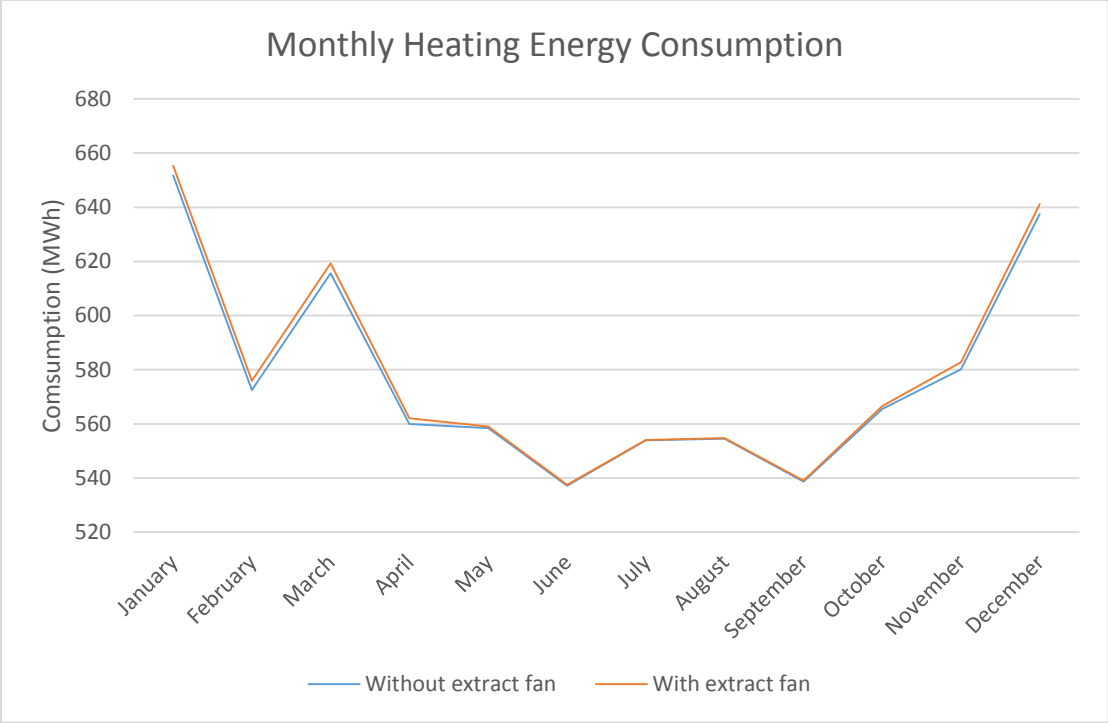

(a) Heating energy consumption result

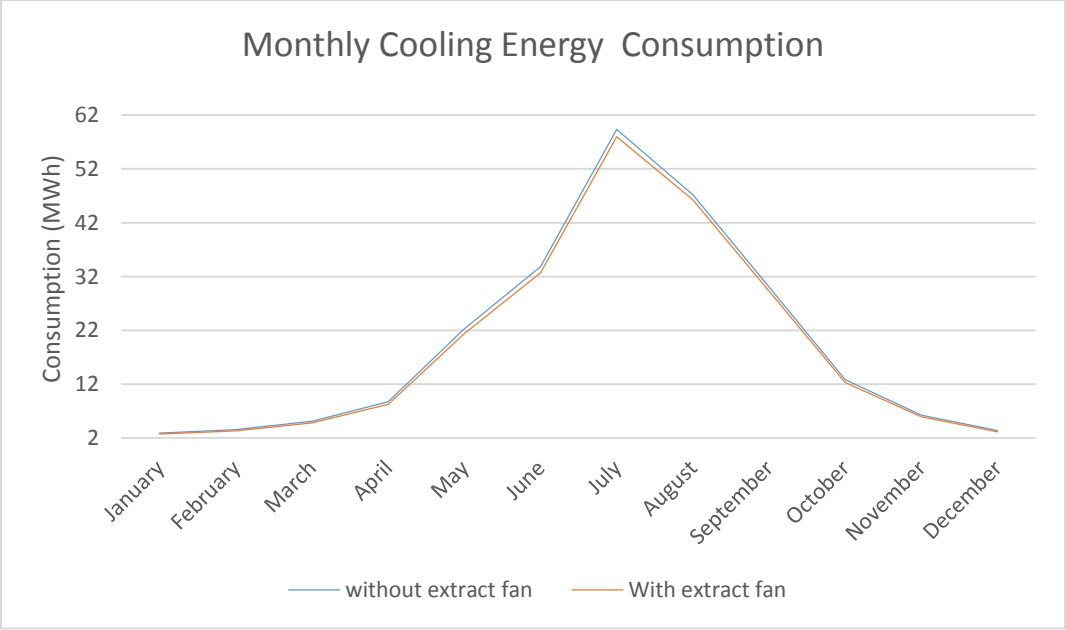

(b) Cooling energy consumption result

Figure 5.13: Impact of DSF cavity extraction fan on the heating and cooling energy consumption

From Figure 5.13(a), showing the heating energy consumption, it demonstrates that there are no energy consumption savings accruing from the operation of the extraction fans in the DSF cavity. This is because the heat gain from solar radiation in the façade is required during the heating to reduce the building's heating load. Moreover, the figure shows that there is a slight increase in heating energy consumption from October to April with the DSF extraction fans in operation.

However, from Figure 5.13(b)'s illustration of the cooling energy consumption, it is observed that the cooling energy consumption savings accruing from the operation of extraction fans in the DSF cavity are marginal. The maximum cooling energy consumption savings are observed from June to August during the summer period. Therefore, from an analysis of the case study result, the optimum schedule of the extraction fan is during the cooling dominant period from May to September. Figure 5.14 demonstrates this by comparing the overall energy consumption results of the building without the extract, with the extract fan in operation all year round and with the extract fan operating only during the summer period.

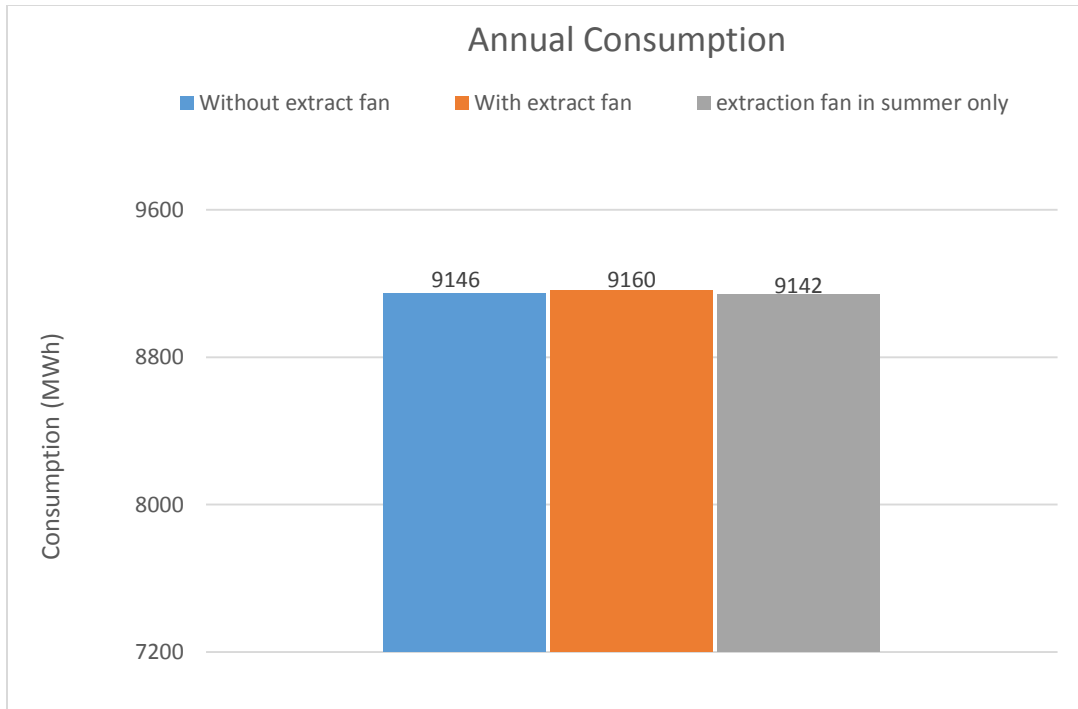

Figure 5.14: Annual overall energy consumption result (without extract fan vs. with extract fan vs extract fan in operation in summer only)

5.4.1 Results of the impact of extraction fans in DSF cavity for the building model simulation in Edinburgh

This section presents the results of the Hilton Heathrow Airport T4 hotel building simulated with the Edinburgh TRY weather data, in order to evaluate the performance of the DSF cavity in such a UK climate zone with relatively colder winter and milder summer.

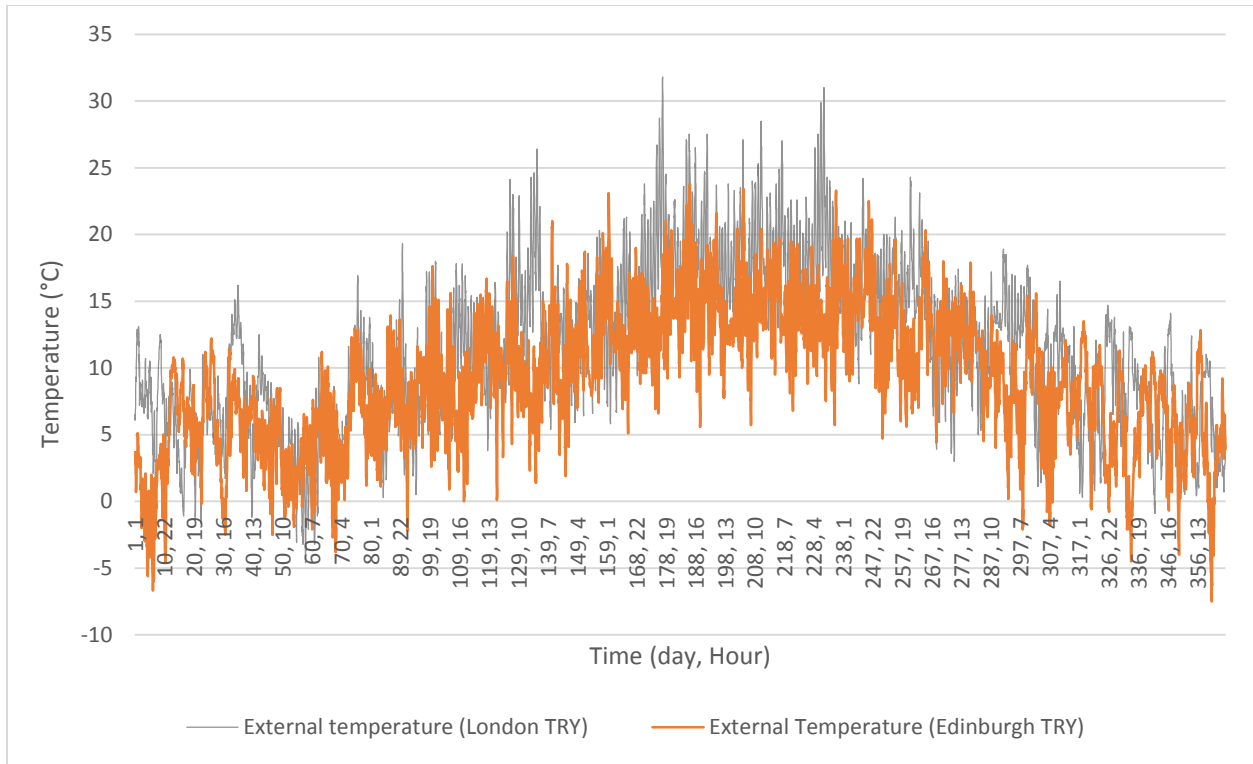
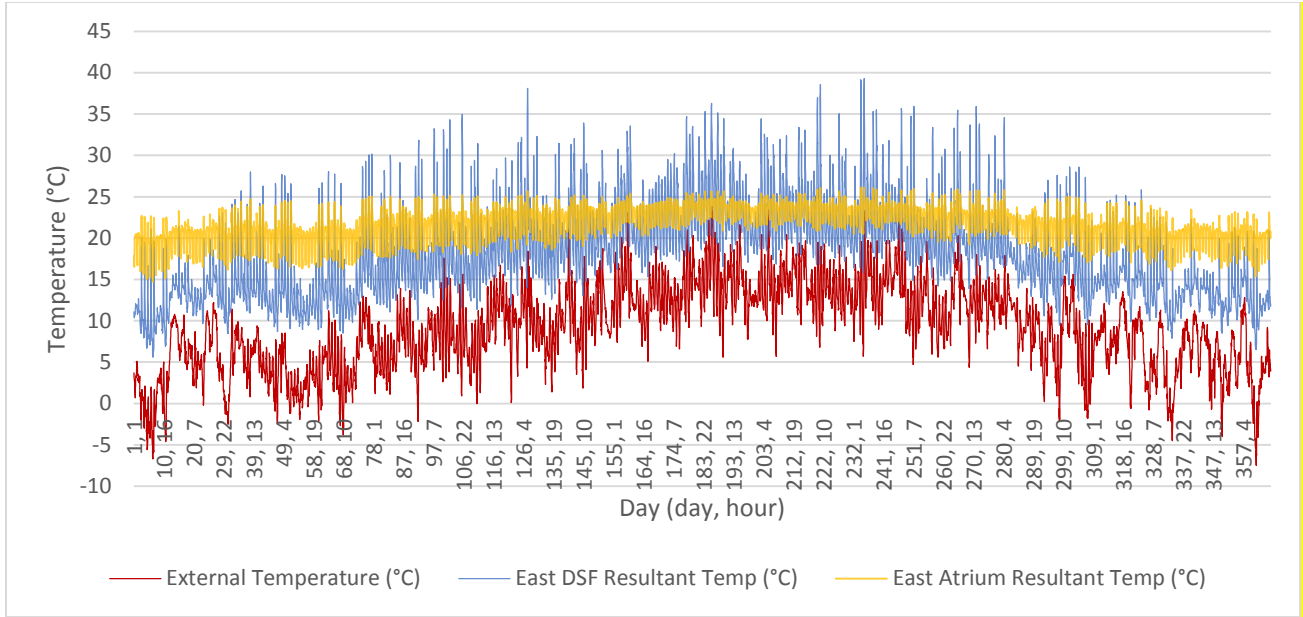
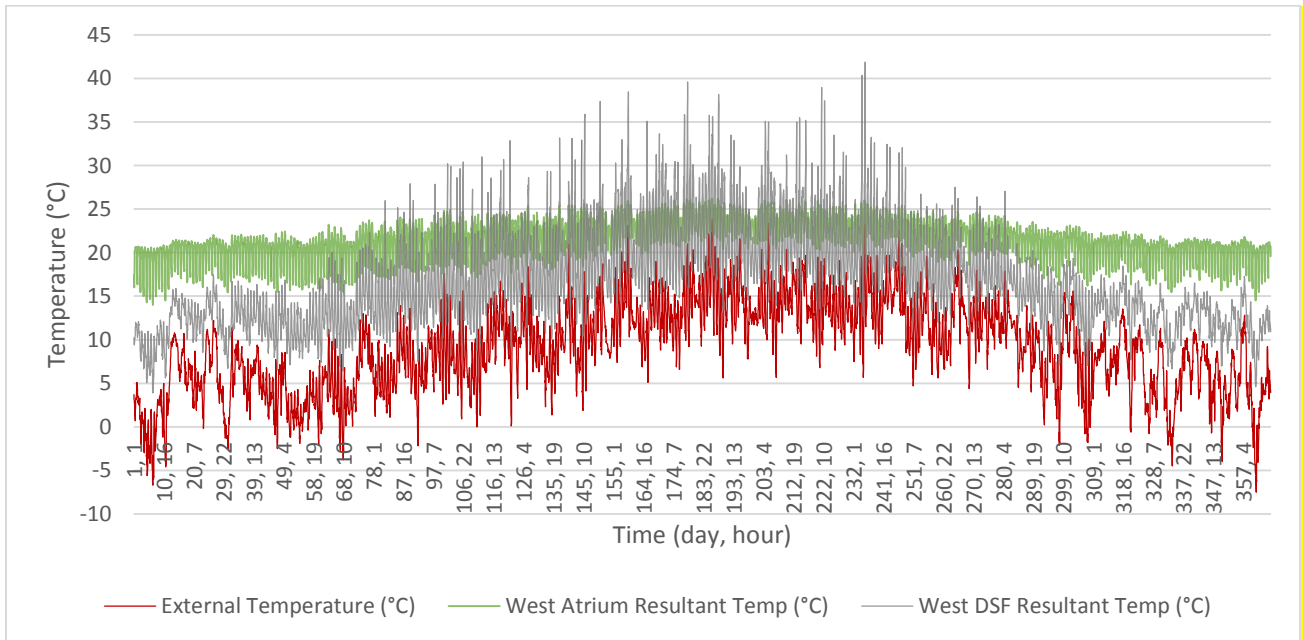

Figure 5.15: External temperature of CIBSE London TRY weather data vs. CIBSE Edinburgh TRY weather data

Figure 5.15 shows the external temperature of the CIBSE London TRY and Edinburgh TRY weather file used for this evaluation. Expectedly, the Edinburgh weather data indicates its relatively colder winter and milder summer climate. However, the weather of both London and Edinburgh have more similarities than differences as they both share the temperate oceanic climates which neither gets very hot nor very cool and quite humid throughout the year.



(a) External temperature, East atrium DSF cavity and East atrium resultant temperature vs time (day, hour)



(b) External temperature, West atrium DSF cavity and West atrium resultant temperature vs time (day, hour)

Figure 5.16: External temperature, DSF cavity temperature and Atrium temperature result without extraction fans vs. time (day, hour) throughout the year (Edinburgh model).

From Figure 5.16, showing the temperature result for the DSF cavity, the adjoining atrium space and external temperature without a DSF cavity extraction fan, it can be noted that the prevailing resultant temperature in both the east and west DSF cavity is generally considerably higher during the summer period than the prevailing resultant temperature in the adjoining atrium space. This is similar to the results of the London model, even though the summer external temperature of Edinburgh is relatively milder. Also, the DSF cavity temperature is generally lower than that observed in the atrium space during the winter season. This considerable temperature difference can have adverse effects on the thermal comfort of the atrium space. Figures 5.17 and 5.18 illustrates further analysis of the noted difference in temperature.

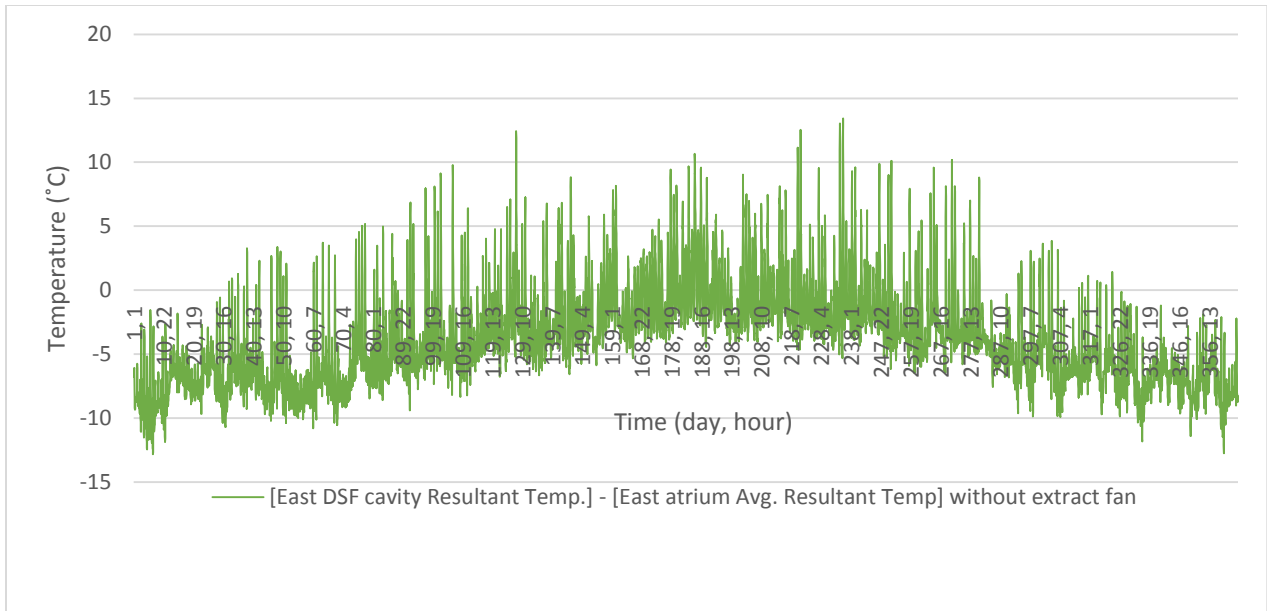

Figure 5.17: Difference in resultant temperature between the east DSF cavity and adjoining central atrium (Edinburgh model without extract fan)

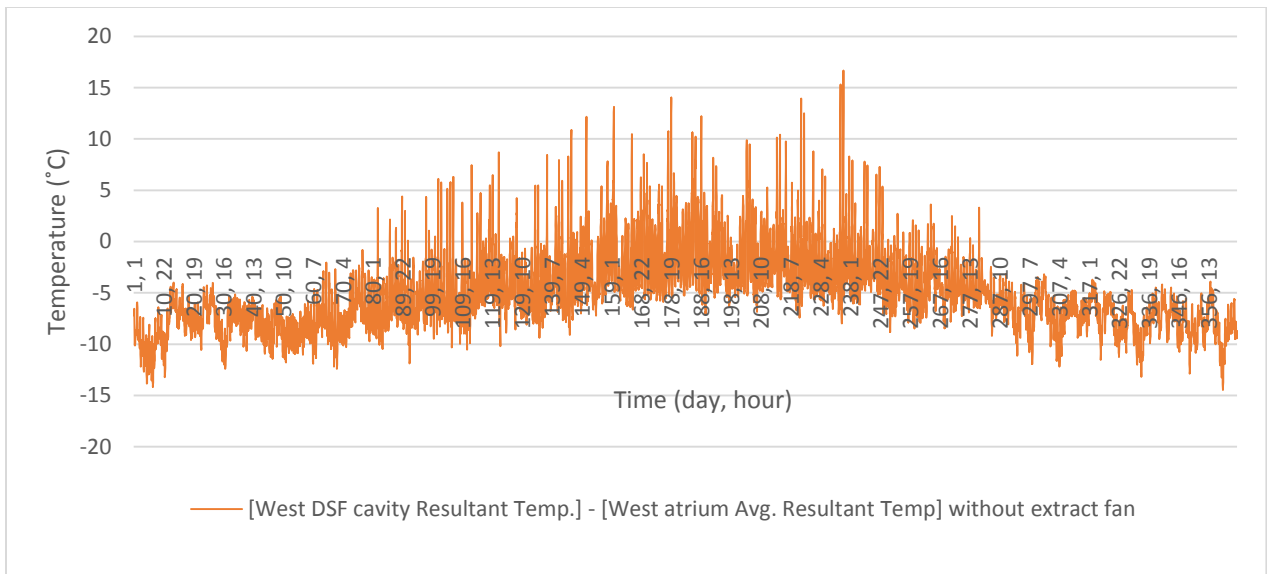
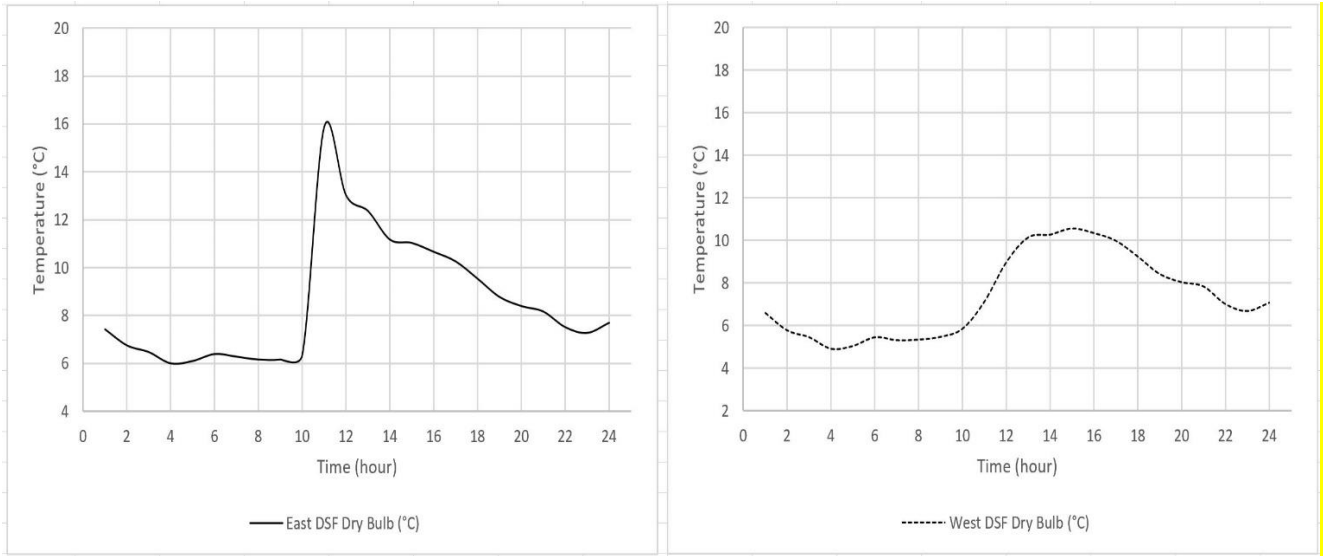

Figure 5.18: Difference in the resultant temperature between the west DSF cavity and adjoining central atrium (Edinburgh model without an extract fan).

It can be observed from 5.17 and 5.18 that the temperature difference between the atrium's DSF façade cavity and the central atrium is quite substantial particularly at the peak of the cooling and heating periods. A temperature difference of between 10 °C to 15 °C is observed at the peak of the cooling period in June, July and August. A similar trend is observed around the peak of the heating period, between October and February, where a temperature difference of -10 °C to -13 °C was obtained. Similar to the results of the London weather model, the significant temperature difference observed from the simulation can significantly affect the heating and cooling loads of the central atrium space especially in warmer weather scenarios, leading to increased risk of overheating and reduction in occupants' thermal comfort. Figures 5.19 and 5.20 present further analysis of the effect of the DSF cavity space by illustrating the results of a typical hot summer day and cold winter day.



(a) East DSF cavity air temperature result for a Cold mostly cloudy day

(b) West DSF cavity air temperature result for a Cold mostly cloudy day

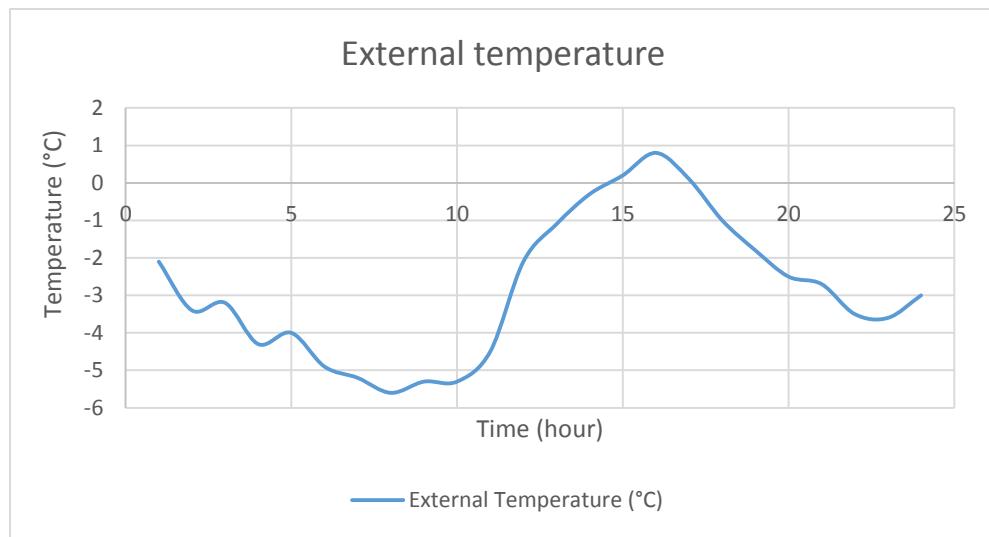

(c) External temperature of the CIBSE TRY weather data for the cold mostly cloudy day

Figure 5.19: DSF Cavity simulation result for a typical cold mostly cloudy day (Edinburgh model)

Figure 5.19 shows the simulation result for a typical cold winter day to demonstrate the impact of the DSF cavity. It can be observed from the figure that air temperature in the East and West DSF cavity increases significantly compared to the cold external temperature towards noon and afternoon especially for the East DSF cavity. This increase in DSF cavity temperature is similar to

that observed for the London weather simulation, despite the relatively colder winter of Edinburgh. Maximum temperature of approximately 16 °C can be observed in the East DSF cavity around noon which is up to 15 °C higher than the maximum external temperature for the day, likewise, maximum temperature of over 10 °C can be observed in the West DSF cavity in the afternoon. Since, the relatively warmer DSF cavity is favourable during the heating season as it contributes towards reducing the heating load of the adjoining atrium central atrium. This result therefore indicates that the DSF cavity which acts as a buffer between the building envelope and the external environment can be even more beneficial during the winter period for the relatively colder Edinburgh climate.

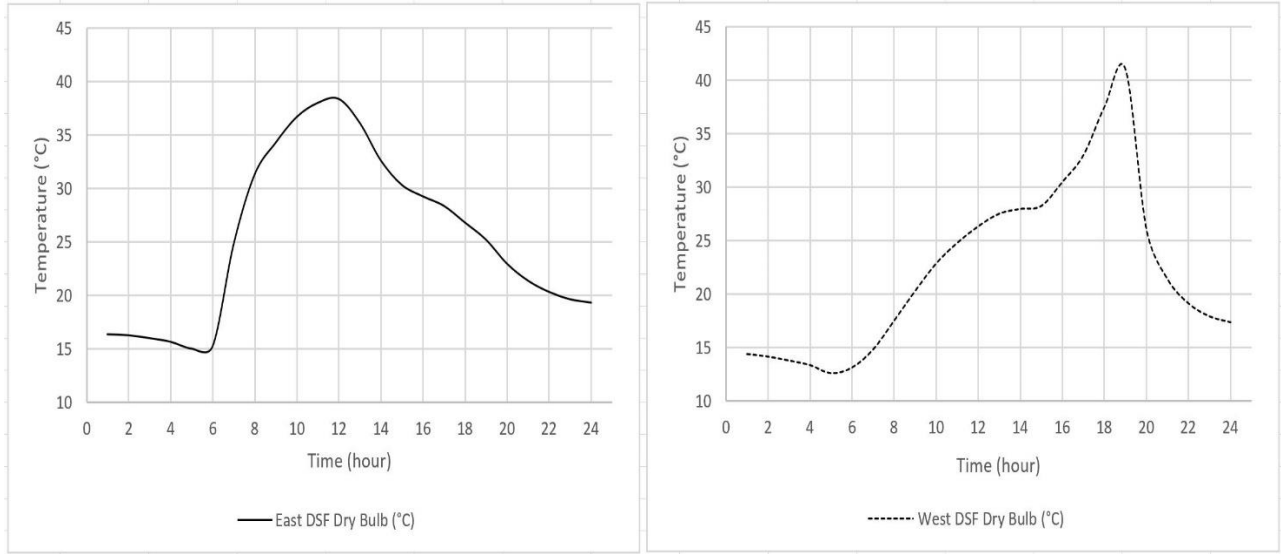

(a) East DSF cavity air temperature result for a Hot sunny day

(b) West DSF cavity air temperature result for a Hot sunny day

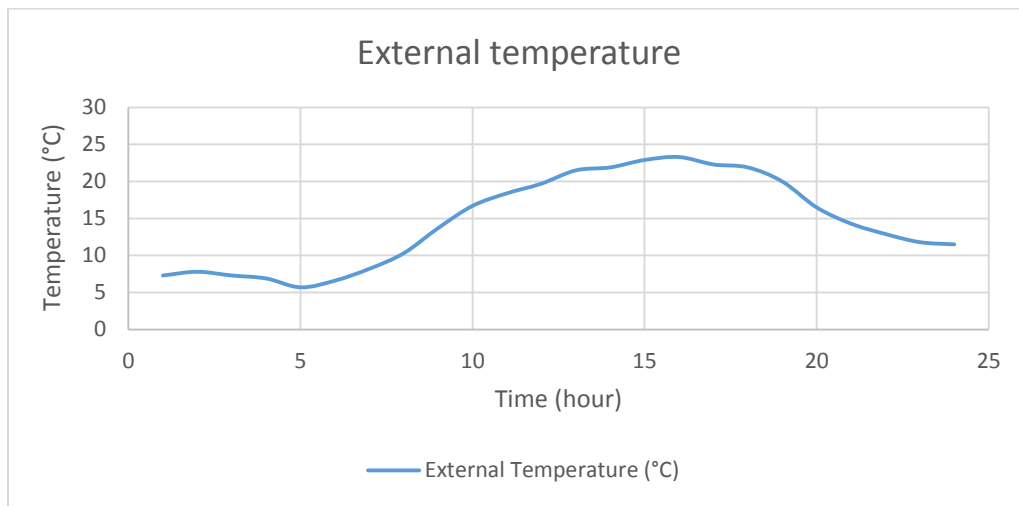

(d) External temperature of the CIBSE TRY weather data for the Hot sunny day

Figure 5.20: DSF Cavity simulation result for a typical Hot sunny day (Edinburgh model)

Similar to the result of the London model, it can be noted from Figure 5.20 showing the simulation result for a typical hot sunny day, that the DSF cavity temperatures in both the East and West DSF are noticeably higher than the prevailing external temperature. Maximum temperature of over 37°C can be observed before noon in the East DSF cavity which is up to 13°C higher than the maximum external temperature for the day. Additionally, in the West DSF cavity, even higher

temperature can be observed with a maximum temperature of over 41°C in the evening which is up to 17 °C higher than the maximum external temperature for the day. Therefore, the prevailing high temperatures noted in the DSF cavity during a typical sunny summer day can have adverse effect on the internal environment of the adjoining central atrium space by increasing the cooling load and resulting to increased risk of overheating.

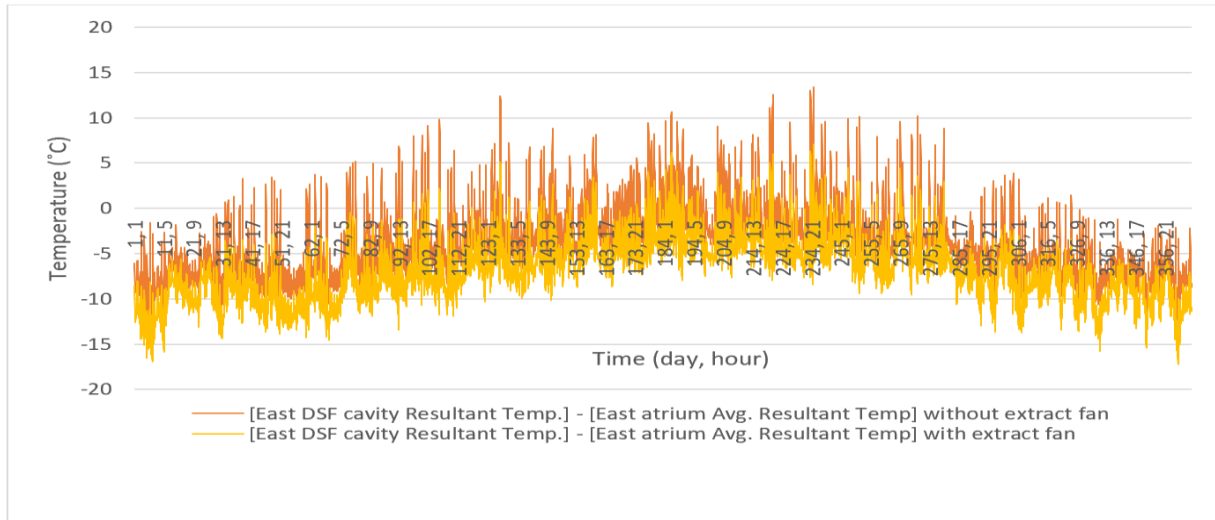

(a) Resultant temperature difference between the East DSF cavity and central atrium (with and without and without extraction fan)

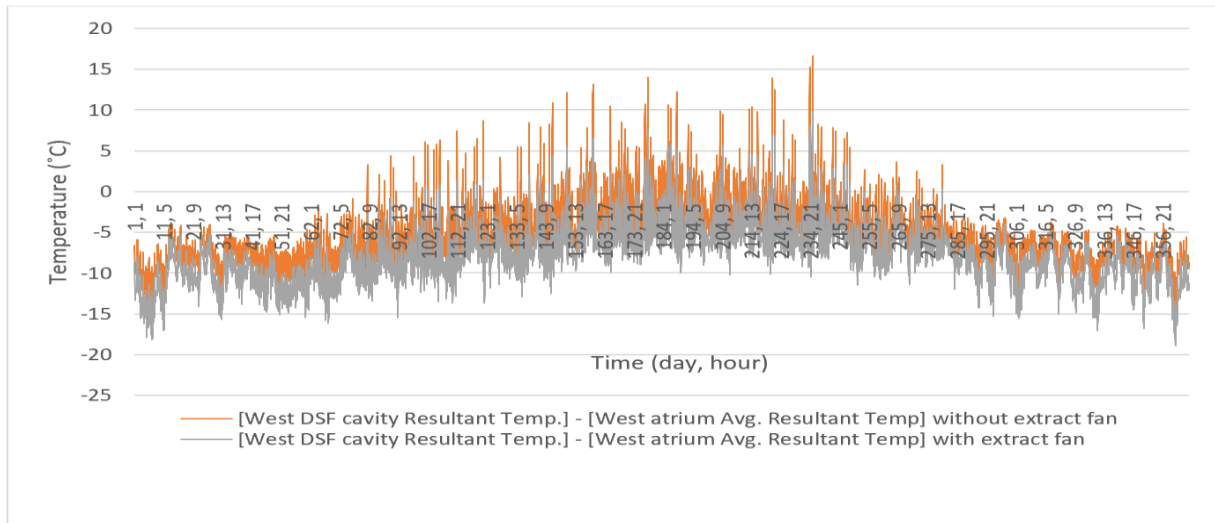

(b) Resultant temperature difference between the West DSF cavity and central atrium (with and without and without extraction fan)

Figure 5.21: Resultant temperature difference between the DSF cavity and central atrium (with and without extraction fan) for Edinburgh model

From Figure 5.21 which presents the comparison of resultant temperature difference between the DSF cavity and the central atrium for the model simulation with and without extraction fan, it can be seen that the installation of the extraction fans generally reduces the prevailing temperature in

the east and west DSF cavity. Consequently, reducing the temperature difference between the east and west DSF and the adjoining central atrium across the year.

Generally, the results of the building model simulated with the Edinburgh weather data demonstrated that the DSF cavity behaviour is relatively similar to that of the London simulation. Therefore, the DSF cavity extract fan ventilation can be beneficial in such a building even in the colder Edinburgh climate particularly during the summer period, thus reducing the risk of overheating and cooling demand. Moreover, the warmer prevailing temperature in the DSF cavity during the heating period is helpful to reduce the heating load, hence the extraction fan is best suited to be operational during the summer periods, as demonstrated in the London simulation results.

5.5 Summary and Conclusion

The case study investigated the impact of extract fans installed in the double skin façade cavity adjoining a large central atrium to the east and west on the thermal performance of the atrium and consequently, the overall energy performance of the hotel building. The case study building is an existing UK hotel building (Hilton London Heathrow Airport Terminal 4) and the simulation was conducted using a building energy simulation software (EDSL TAS). The software's energy estimate and thermal performance results were validated with actual building consumption data and thermal sensor recordings before simulation and evaluation of the effect of the installed façade extract fans on the energy performance of the case study building.

The case study results demonstrated that the resultant temperature of the DSF cavity adjoining the central atrium is substantially high without extraction fans. The temperature difference between

the DSF cavity and the atrium space of up to 11°C is observed in summer times and similarly, a temperature difference of up to -12°C is observed during the winter. This significant temperature difference between the façade cavity and the atrium space poses the risk of overheating and occupant discomfort, especially during the summer. Furthermore, a simulation of the hotel building model was conducted using the weather data of Edinburgh to evaluate the thermal behaviour of the building in a relatively colder region of the UK. The results of the Edinburgh simulation demonstrated that the DSF cavity had similar performance to the London simulation, as the resultant temperature of the DSF cavity adjoining the central atrium is significantly high without extraction fans, especially during the summer.

The result of the model's simulation incorporating extract fans in the façade cavity indicates that the resultant temperature difference between the DSF façade cavity and the central atrium reduces significantly relative to the models without extraction fans. This reduced temperature difference results in improved internal temperature of the atrium space, marginally reducing the cooling demand during the summer but also slightly increasing the winter heating requirement. The result of the overall energy consumption shows that there is a marginal increase of 0.2% in the annual energy consumption when the extraction fans are in operation throughout the year.

However, the annual energy consumption result of the simulation with the extract fans operating from May to September and off from October to April demonstrates that the 0.2% marginal energy consumption increase is negated. Therefore, to improve the internal condition of the atrium space without an increase in overall energy consumption, the optimum schedule of the extraction fan is during the cooling dominant period from May to September.

Chapter 6: Impact of Window Films on the Energy Performance of Existing UK Hotel Buildings

6.1 Introduction

The quest for improved energy efficiency and thermal comfort in existing buildings most often involves an all-encompassing approach, incorporating an enhanced cost-effective building fabric retrofit. As highlighted from the literature review in a preceding chapter of this thesis, windows are responsible for a substantial proportion of wasted heat in a heating dominant climate and solar heat gain in cooling dominant climates. This challenge has significant adverse effects on the energy consumption of buildings in general. Therefore, it has become very crucial that energy efficient façades and windows are used in order to reduce the CO₂ emissions throughout the operational life cycle of a building (Ihara *et al.*, 2015). The Glass and Glazing Federation (2012) highlighted that up to 40% of a building's load on the cooling system or air conditioners can be associated with solar gains through the windows. Moreover, air conditioning use in the UK has increased considerably in the past two decades and cooling a building usually requires more energy than heating (Glass and Glazing Federation, 2012). Therefore, the need to reduce the solar transmission through building windows in a cost-effective manner has become increasingly important especially in light of increased concerns of global warming.

Window films are retrofit and are generally designed to keep out the sun thereby reducing the cooling load and consequently lowering energy consumption and CO₂ emissions. According to Plummer (2015), window films are commonly polyester products that can be applied to glass. They are usually made from several layers of coated or chemically processed polyester; some have a lightly metalised layer for improved solar attributes. Although, there are several types of window films, the ones developed to control solar radiation are most widespread. Some of the benefits of

window films include: providing protection against the adverse effects of the sun (such as severe heat, fading and ultraviolet radiation); enhanced security and increased privacy and aesthetic purposes (Plummer, 2015). Furthermore, the application of other advanced window glazing improvement systems (such as, tintable smart windows, solar energy control and reversible airflow windows) in existing buildings may result in disturbance to the occupants (Li *et al.*, 2015) whereas, the application of window films on glazing has the capability to regulate the penetration of light and heat and also screen out Ultra-Violet (UV) light, whilst posing the least disturbance to the building occupants (Li *et al.*, 2015). This chapter evaluates the impact of two commercially available window films on the overall energy consumption and performance of existing UK hotel buildings using case studies of two different hotels with distinct building facades and construction. The feature of the first case study building (Hilton Reading Hotel) is mainly a single-skin-glazed curtain wall structure with a relatively high window to wall ratio, whereas, the second case study building (Hilton London Heathrow Airport Terminal 4 Hotel) is a conventional building with a primarily framed structure, cavity walling and double-glazed windows.

6.2 Building Description

The description of the first case study building (Hilton Reading Hotel) and second case study building (Hilton London Heathrow Airport Terminal 4 Hotel) used for this evaluation are provided in preceding sections 4.2.1 and 4.2.2 respectively.

6.3 Study Method

The general methodology and core processes that were used to develop the holistic models on the dynamic simulation software TAS are presented in preceding sections 3.7 to 3.10. However, some information specific to this case study is presented in this section.

The process that was employed to achieve the aim with the case study buildings can be categorised into two distinct stages. The first stage involves estimating the energy consumption of the building by developing a holistic model reflecting the building fabric, systems and thermal performance of the actual building. The predicted energy consumption is validated by comparing against actual consumption data. These data are collected by survey of the case study building to enable verification of available data such as building fabric data (e.g. walls and windows), occupancy information to ensure simulation assumptions are realistic, building usage to ensure zone grouping is as shown on the architectural plan and HVAC system characteristics. The second stage entails the application of the window films to the model to evaluate their impact.

6.3.1 3D modelling

The information used to develop the 3D model for building simulation was collected from the AutoCAD drawings of the hotel building. These drawings, as noted in section 3.7, provide the required data on the building geometry, layout and functional use of the numerous zones of the building. The Reading Hilton Hotel AutoCAD plans for the individual floors used in this case study are presented in Figure 4.1, section 4.2.1 of this thesis. While Figure 4.2 in section 4.2.2 shows the individual AutoCAD floor plans for Hilton London Heathrow Airport T4 Hotel:

6.3.2 Simulation process

TAS as an energy modeller undertakes the dynamic thermal simulation of the building, which is done by the TBD component of the software. This modelling stage requires careful and judicious selection of modelling parameters. The required simulation parameters of calendar, weather data, building elements, zones, internal condition and aperture types were populated to perform the thermal performance of the building. Figure 3.3 in section 3.7 shows the thermal simulation

process employed. While Tables 4.2 to 4.4 in section 4.3.2 present the modelling parameters and assumptions based on the characteristics for Hilton Reading Hotel. Similarly, Tables 4.5 – 4.7 in section 4.3.2 present the modelling parameters and assumptions base the case study building's characteristics for Hilton London Heathrow Airport Terminal 4 hotel. Furthermore, Figure 6.1 shows a summary of the case study method:

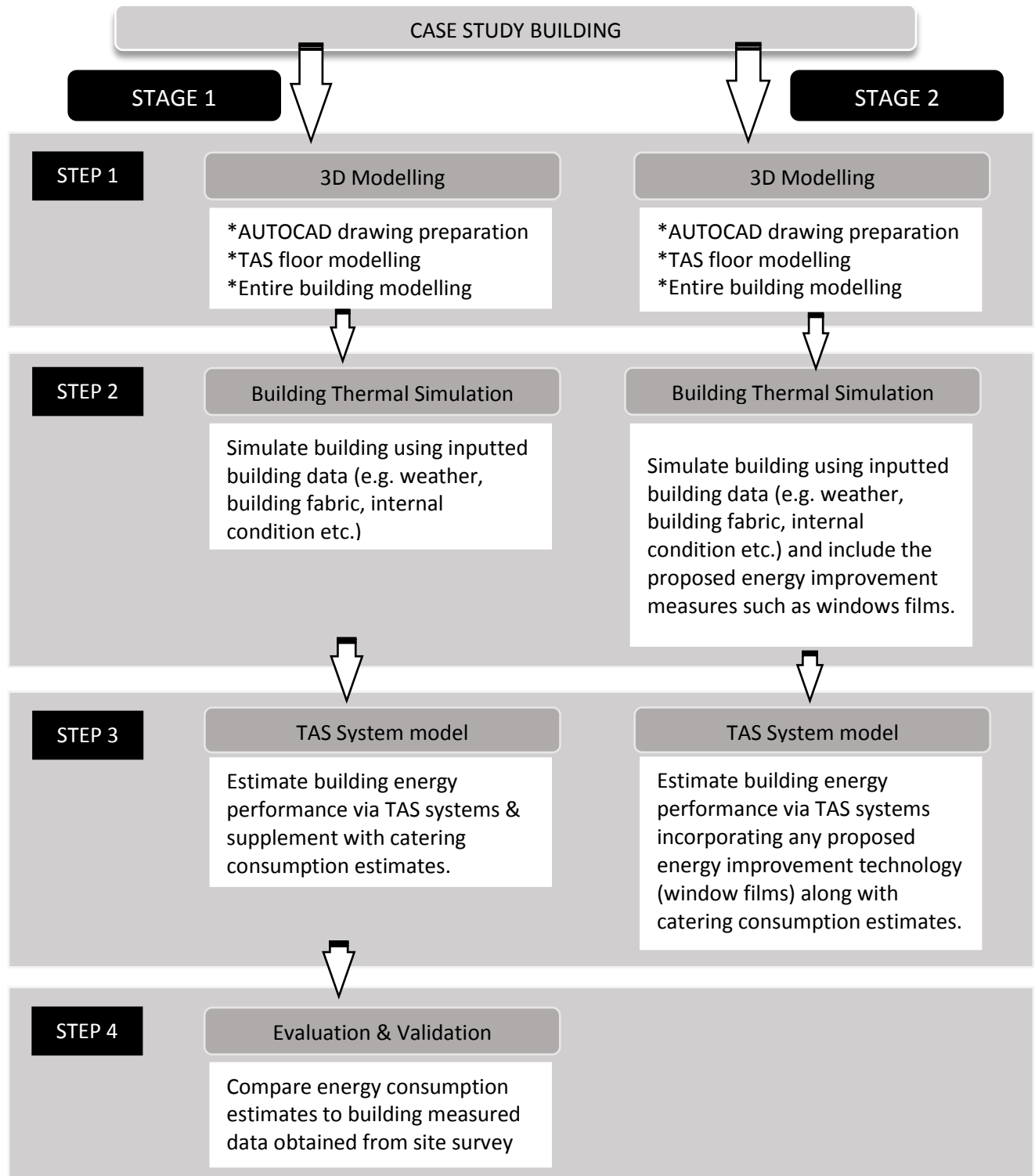

Figure 6.1: Summary of case study method

The two window films simulated in this case study are the 3M sun control window film (Prestige 70 Exterior and Prestige 40 Exterior). They consist of a multilayer, metal free and spectrally selective durable anti-scratch solar films (3M, 2016). The main distinction between the two films is in their appearance and the amount of light transmission through them. The numbers 70 and 40 in the names of the films are associated with the visible light transmission. Hence, the Prestige 70 Exterior (PR 70 EXT) looks virtually clear (similar to the appearance of typical car window glass) while the Prestige 40 Exterior (PR 40 EXT) has a warm bronze appearance, but still offers relatively good light transmission. Tables 6.4 and 6.5 illustrate the performance attributes of PR 70 EX and PR 40 EXT window films respectively when applied to a typical single pane clear or tinted window and to a double- pane clear or tinted window.

Table 6.1: Performance Properties of PR 70 EXT applied to a typical single and double pane clear or tinted window (3M, 2016)

Glass type	Visible light			G value (SHGC)	LSG (light to solar gain)	UV Block (%)	Heat Gain Reduction (%)	Glare Reduction (%)
	Reflected (interior) %	Reflected (exterior) %	Transmission %					
Single Pane								
Clear	7	7	71	0.48	1.5	99.9	41	20
Tinted	5	6	42	0.39	1.1	99.9	39	20
Double Pane								
Clear	14	12	63	0.39	1.6	99.9	45	20
Tinted	13	7	38	0.29	1.3	99.9	43	21

Table 6.2: Performance Properties of PR 40 EXT applied to a typical single and double pane clear or tinted window (3M, 2016)

Glass type	Visible light			G value (SHGC)	LSG (light to solar gain)	UV Block (%)	Heat Gain Reduction (%)	Glare Reduction (%)
	Reflected (interior) %	Reflected (exterior) %	Transmission %					
Single Pane								
Clear	5	6	42	0.39	1.1	99.9	53	53
Tinted	5	5	25	0.33	0.8	99.9	47	53
Double Pane								
Clear	13	7	37	0.29	1.3	99.9	59	53
Tinted	12	6	22	0.23	1.0	99.9	55	53

6.4 Results and Discussion for Impact of Window Films on Hilton Reading

Hotel (Glazed Curtain Wall)

The results and discussion of results for the Reading Hilton Hotel building with a glazed curtain wall is presented in this section. Preceding section 4.4.1 of this thesis presented the results and discussion of results for the first stage of this case study building (Hilton Reading hotel) which involves estimation and validation of the case study building the energy consumption (that is the base model without window film).

6.4.1 Case study result with window films on all orientations of the building

The results of the next stage of simulation for this case study, which incorporates the window films on all orientations of the model, is presented in Figures 6.2 to 6.7. Although the windows of the case study building are double pane clear windows, the simulation results presented are for the window films applied to both clear and tinted double glazed windows. This is done to examine if

there is a considerable performance difference for the films applied to the two possible window variants (clear or tinted). Therefore, the legend on the presented figures represent the following:

- Simulation without window films
- Simulation with 3M 40 EXT clear: represents simulation result with 3M 40 EXT applied to a clear window.
- Simulation with 3M 40 EXT tint: represents simulation result with 3M 40 EXT applied to a tinted window.
- Simulation with 3M 70 EXT clear: represents simulation result with 3M 70 EXT applied to a clear window.
- Simulation with 3M 70 EXT tint: represents simulation result with 3M 70 EXT applied to a tinted window.

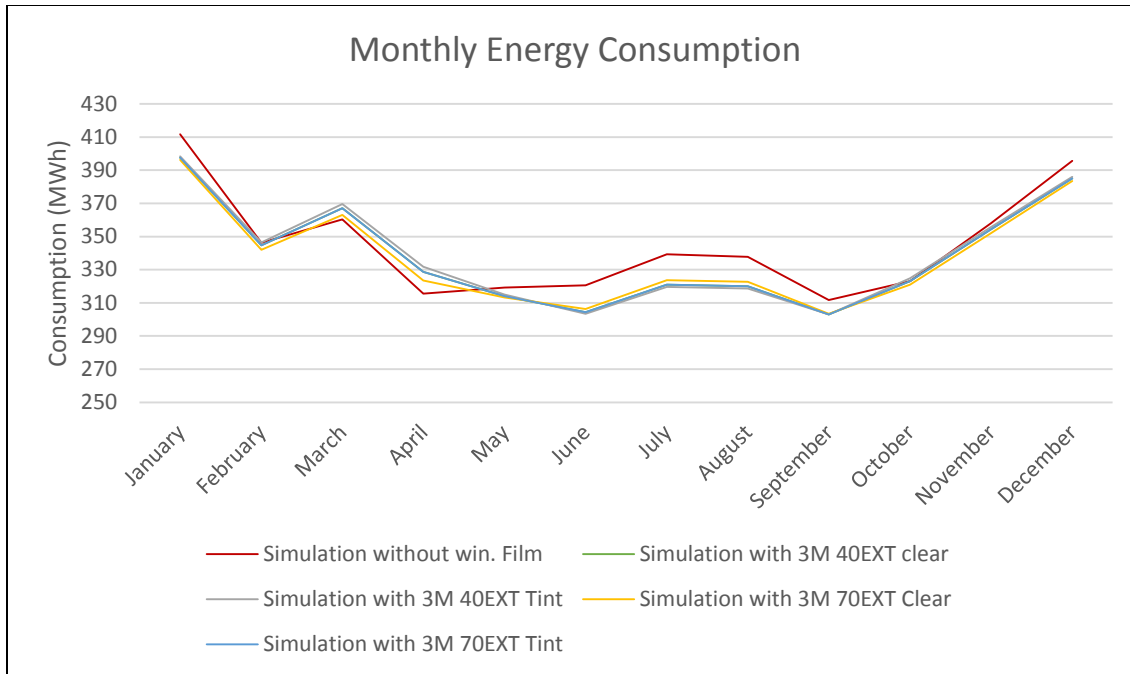

(a) Monthly overall energy consumption result

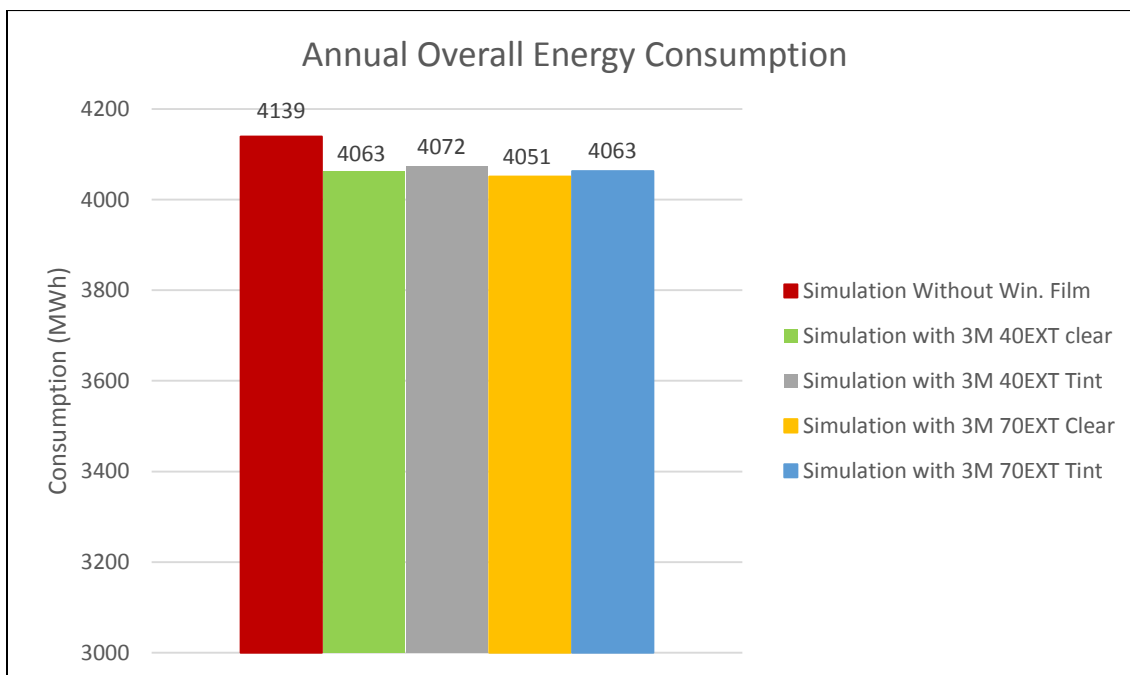

(b) Annual overall energy consumption result

Figure 6.2: Simulation overall energy consumption result

Figure 6.2 illustrates the overall energy consumption result for the simulation evaluating the impact of the window films compared to the baseline model without the window films. As the simulation result is presented for comparison purposes, the numerical total does not include catering energy consumption, which is constant for all scenarios. From Figure 6.2(a), it can be observed that the overall energy savings accruing from the application of the window films across the year is not huge with most of the saving occurring from May to September, which is the cooling dominant period. Additionally, there is a marginal reduction in energy consumption in January and December during the peak of the heating season. Figure 6.2(b) shows the observed marginal reduction in total annual energy consumption for the simulation with a percentage reduction of 1.9% and 1.6% for window film (3M 40 EXT) applied to clear and tinted windows; 2.1% and 1.9% for window film (3M 70 EXT) applied to clear and tinted windows.

Although the impact of the window film on the overall energy is not significant, it is insightful to evaluate the impact of the window films on the components of the energy consumption that they have direct influence on. Therefore, the energy consumption results for heating and cooling are presented in Figures 6.3 and 6.4:

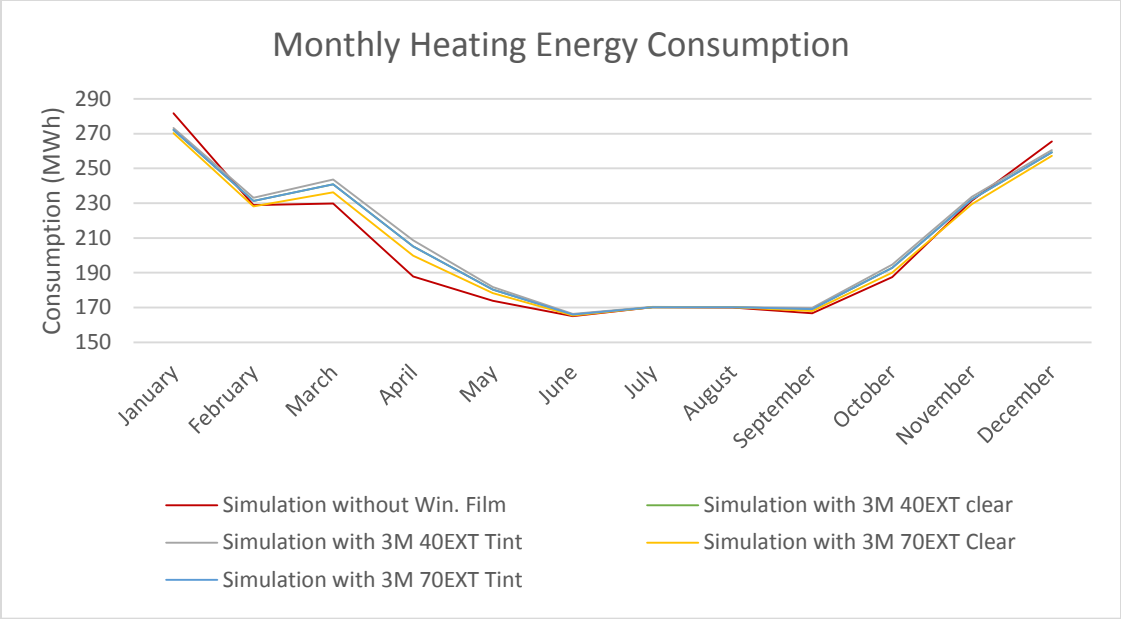

(a) Monthly heating energy consumption results

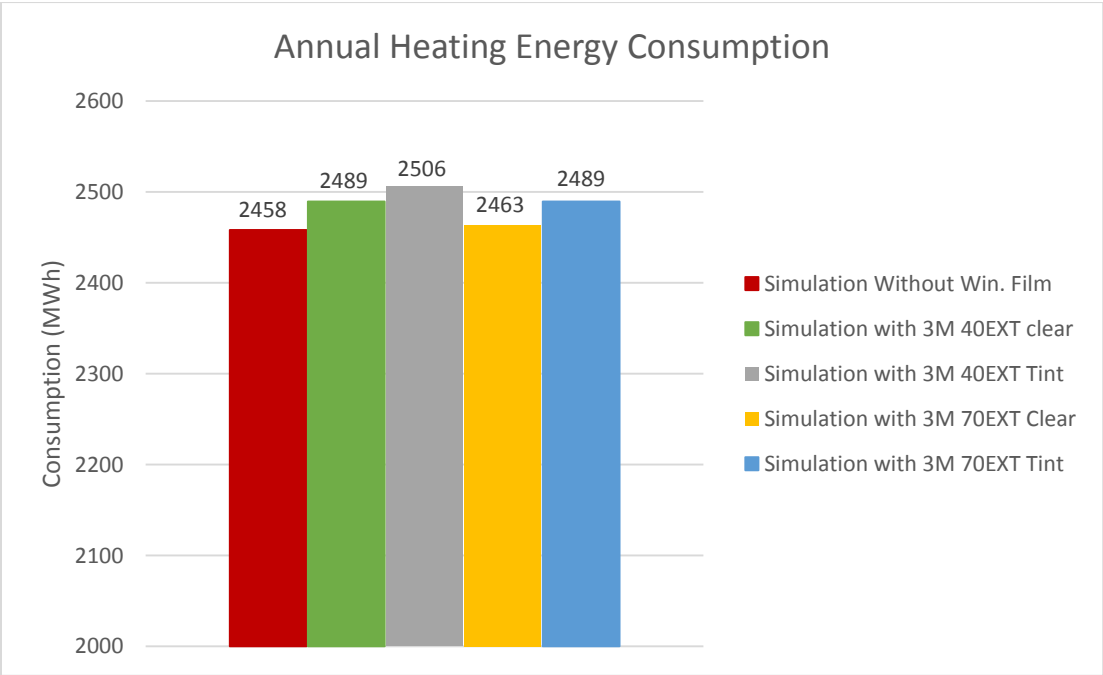

(b) Annual overall heating energy consumption results

Figure 6.3: Impact of window films on heating energy consumption

From Figure 6.3(a), showing the monthly heating energy consumption, it can be seen that there are no heating energy consumption savings accruing from the application of the window films. This can be attributed to the fact that the window films mainly reduce the amount of solar heat gain through the windows, which is required during the heating season to reduce the heating demand. Moreover, the figure indicates an increase in the heating energy consumption mainly from February to May with a maximum increase in April. The maximum percentage increase in heating energy consumption of 9% and 11% was observed for window film (3M 40 EXT) applied to clear and tinted windows respectively while reductions of 6% and 9% were observed for window film (3M 70 EXT) applied to clear and tinted windows.

Furthermore, Figure 6.3(b), presenting the annual overall heating energy consumption, shows a similar trend to that observed in Figure 6.3(a). The figure illustrates that there is a marginal increase in the overall heating energy consumption across the year of 1.3% and 2% for window film (3M 40 EXT) applied to clear and tinted windows. Also, an increase in the overall heating energy consumption of 0.2% and 1.3% was observed for window film (3M 70 EXT) applied to clear and tinted windows.

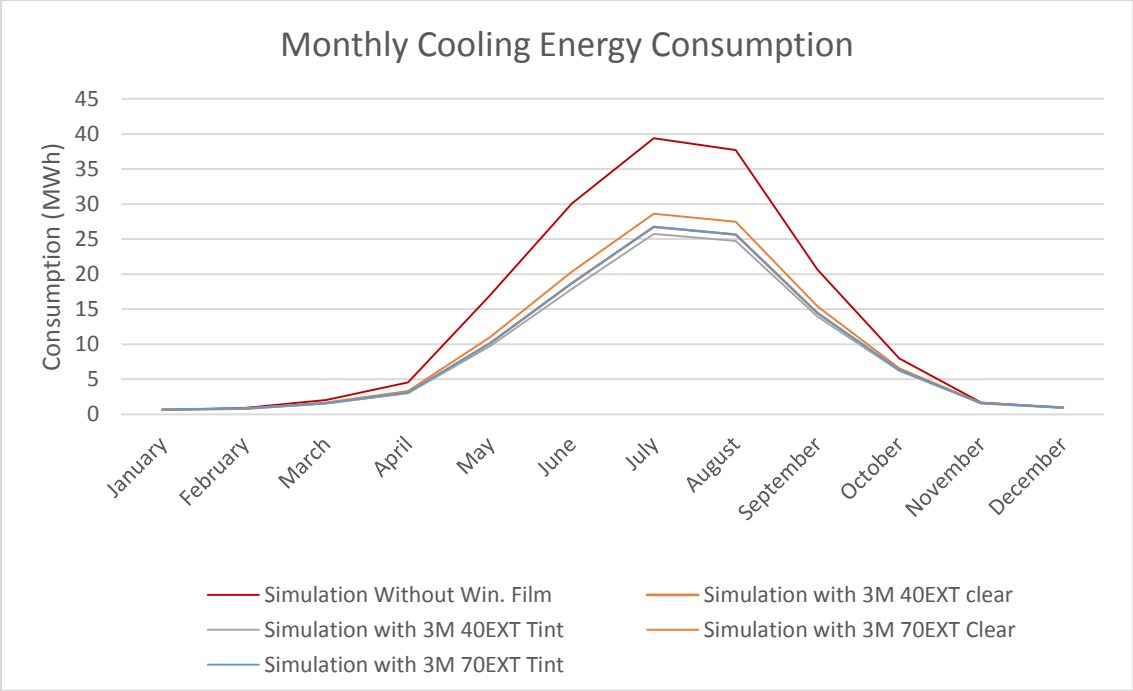

(a) Monthly cooling energy consumption results

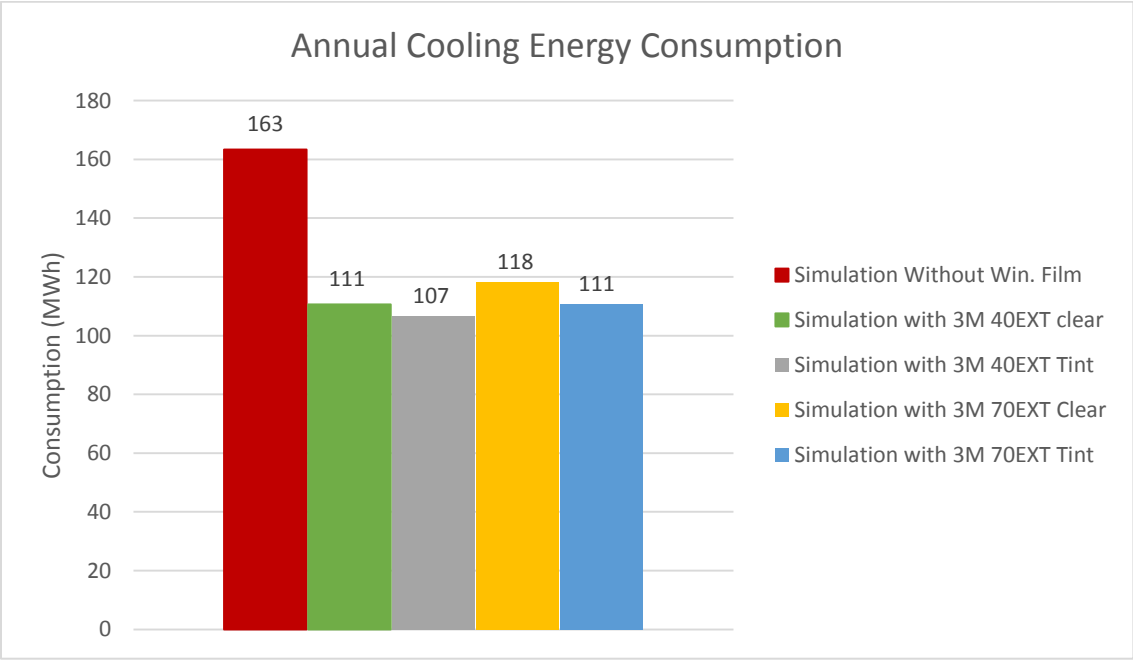

(b) Annual overall cooling energy consumption results

Figure 6.4: Impact of window films on cooling energy consumption

It can be observed from Figure 6.4(a), which shows the monthly cooling energy consumption, that the cooling energy consumption savings accruing from the application of the window films is substantial. This can be attributed to the fact that the window films mainly reduce the amount of solar heat gain through the window pane resulting in cooling load reduction during the cooling dominant period. Furthermore, the figure shows that the bulk of the cooling energy savings is from April to October with the maximum energy consumption reduction occurring in July around the peak of the summer. The maximum percentage cooling energy reduction of 32% and 35% was observed for window film (3M 40 EXT) applied to clear and tinted windows with respect to the results without films. In addition, a reduction of 27% and 32% was observed for window film (3M 70 EXT) applied to clear and tinted windows.

Figure 6.4(b), showing the annual overall cooling energy consumption, also indicates a similar cooling energy saving trend to that observed in Figure 6.4(a). The figure shows that there is a significant reduction in cooling energy consumption across the year of 32% and 35% for window film (3M 40 EXT) applied to clear and tinted windows and a reduction in cooling energy consumption of 28% and 32% for window film (3M 70 EXT) applied to clear and tinted windows. The critical analysis of the heating and cooling energy consumption demonstrates that there is a considerable reduction in cooling energy consumption from the application of the window films.

Evaluation of the effect of the window films on individual days, such as a typical hot sunny summer day and a mostly clear winter day can provide further understanding of the impact of the window films. Particularly since the preceding analysis of result as indicated that the installation of the window films mainly impacts the heating and cooling energy consumption due to the solar heat reduction properties of the window films.

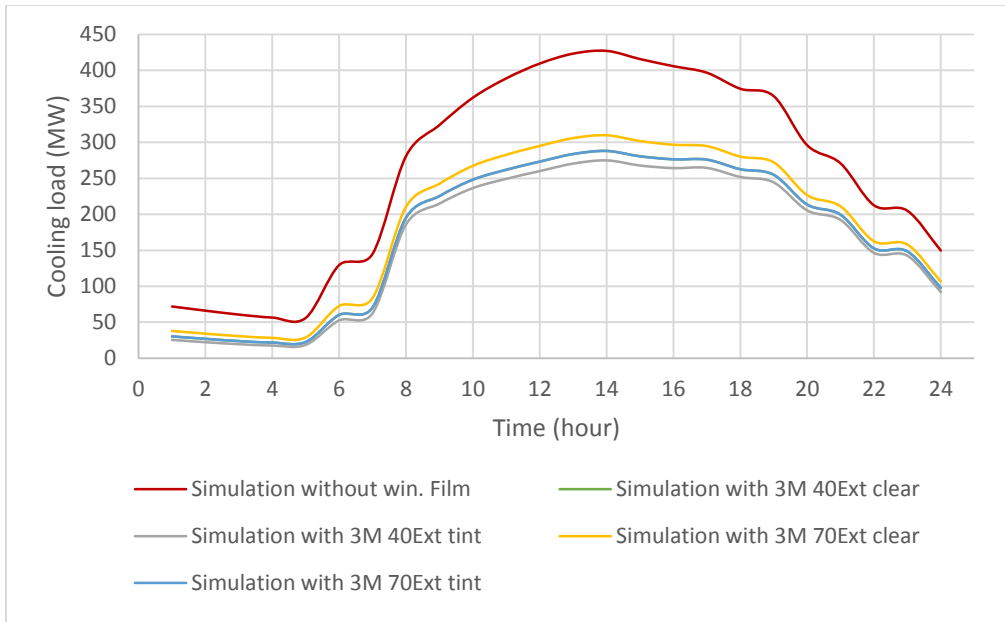

(a) Hourly cooling load profile

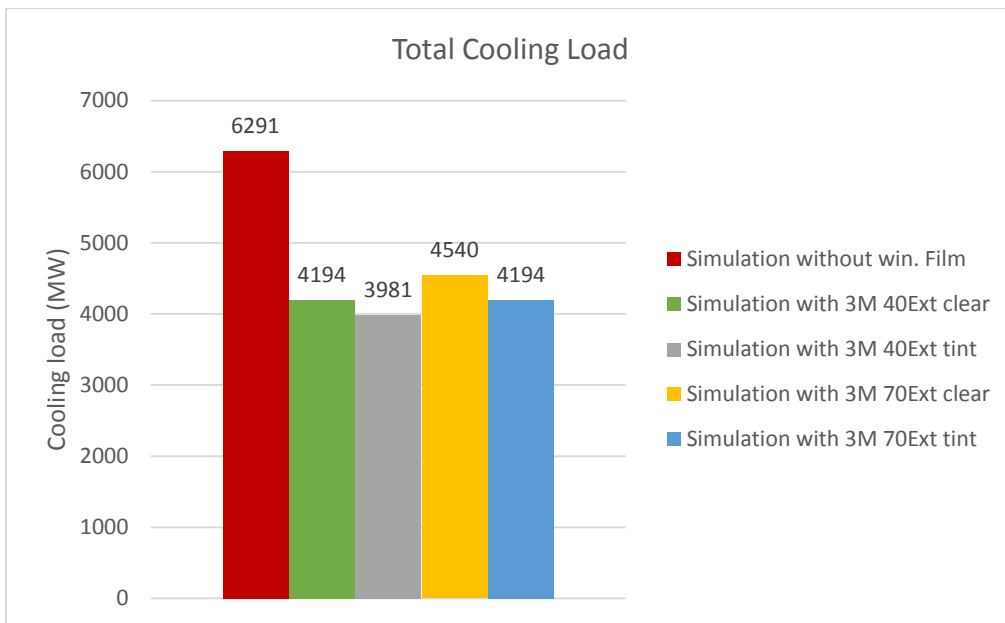

(b) Total daily cooling load

Figure 6.5: Impact of window films on the cooling load profile for a typical hot sunny summer day.

From Figure 6.5 showing the impact of the window films on the cooling load profile of the building for a typical hot sunny summer day, it can be observed that the window films generally resulted in

substantial reduction of the cooling load, especially during the longer summer daylight period. The maximum percentage cooling load reduction of 33% and 36% was observed for window film (3M 40 EXT) applied to clear and tinted windows with respect to the results without films. In addition, a reduction of 27% and 33% was observed for window film (3M 70 EXT) applied to clear and tinted windows. It can also be noted from figure 6.5(b) that the percentage reduction of 33% and 37% in the total daily cooling load for window film (3M 70 EXT) applied to clear and tinted windows and a reduction in total cooling load of 27% and 33% for window film (3M 70 EXT) applied to clear and tinted windows. The result of the cooling load profile for a typical hot summer day explains the considerable reduction in cooling energy consumption observed during the cooling dominant period as illustrated in figure 6.4.

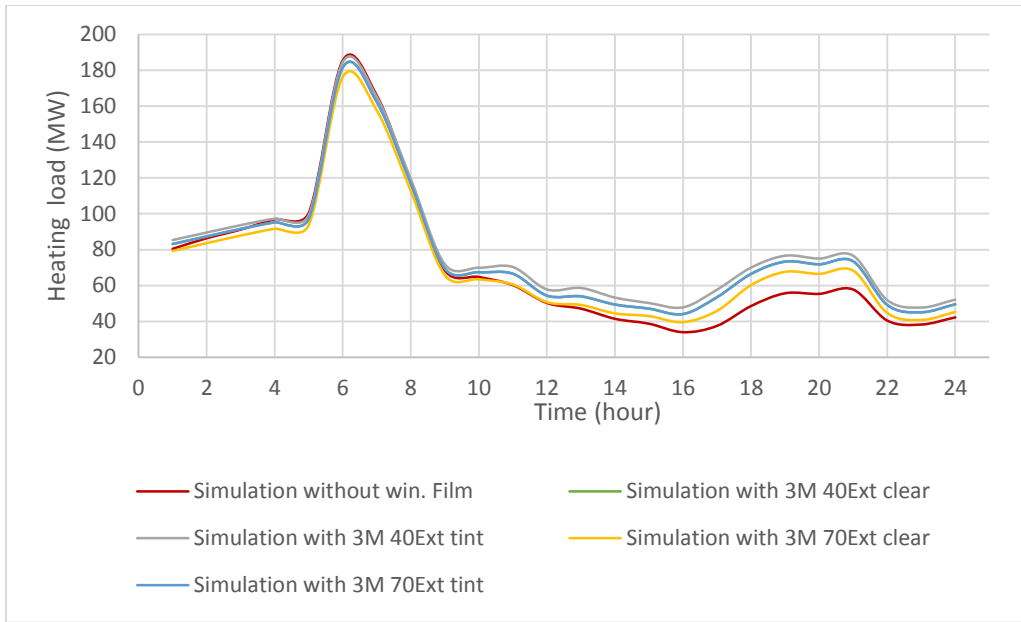

(a) Hourly Heating load profile

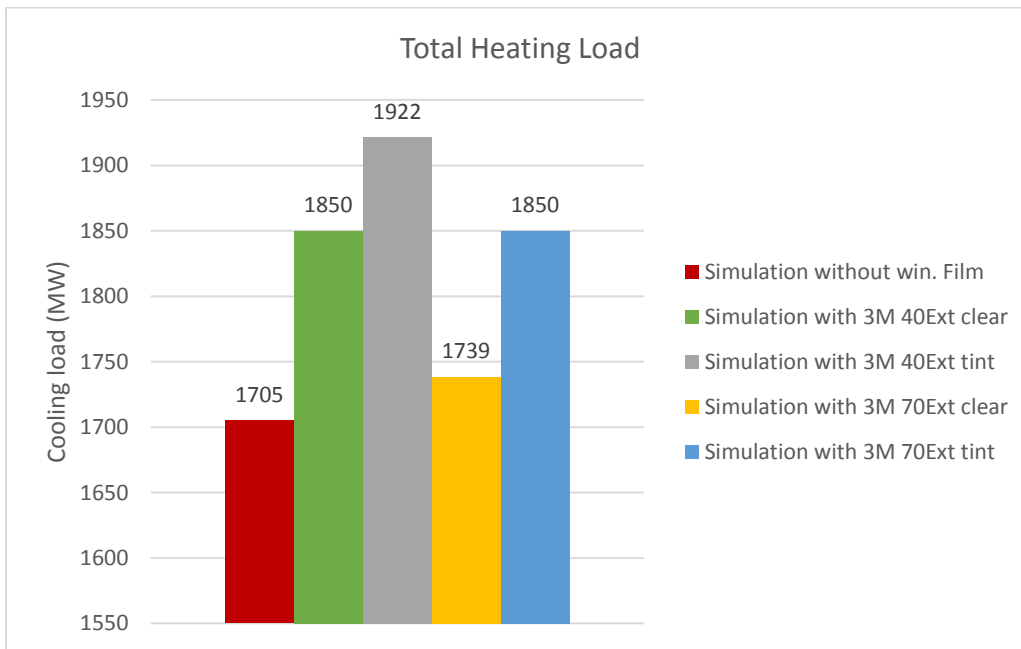

(b) Total daily heating load

Figure 6.6: Impact of window films on the heating load profile for a typical cold mostly clear winter day

Similar to the result of the cooling load profile for a typical hot summer day, the result of the impact of the window films on the heating load profile for a typical cold winter day illustrated in Figure 6.6 explains the increase in overall heating energy consumption observed in Figure 6.3. Since it can be seen from Figure 6.6 that the application of the window films generally resulted in the increase of the heating load across the day. As previously highlighted, the increase in heating load from the application of the films is due to the solar heat reduction attribute of the films which diminishes the solar heat gain from the windows that is beneficial during the heating period to reducing the heating load. From Figure 6.6(b), presenting the total daily heating load, there is increase in the total heating load during the typical cold winter day of approximately 9% and 13% for window film (3M 40 EXT) applied to clear and tinted windows. Also, increase in the total heating load of 2% and 9 % was observed for window film (3M 70 EXT) applied to clear and tinted windows.

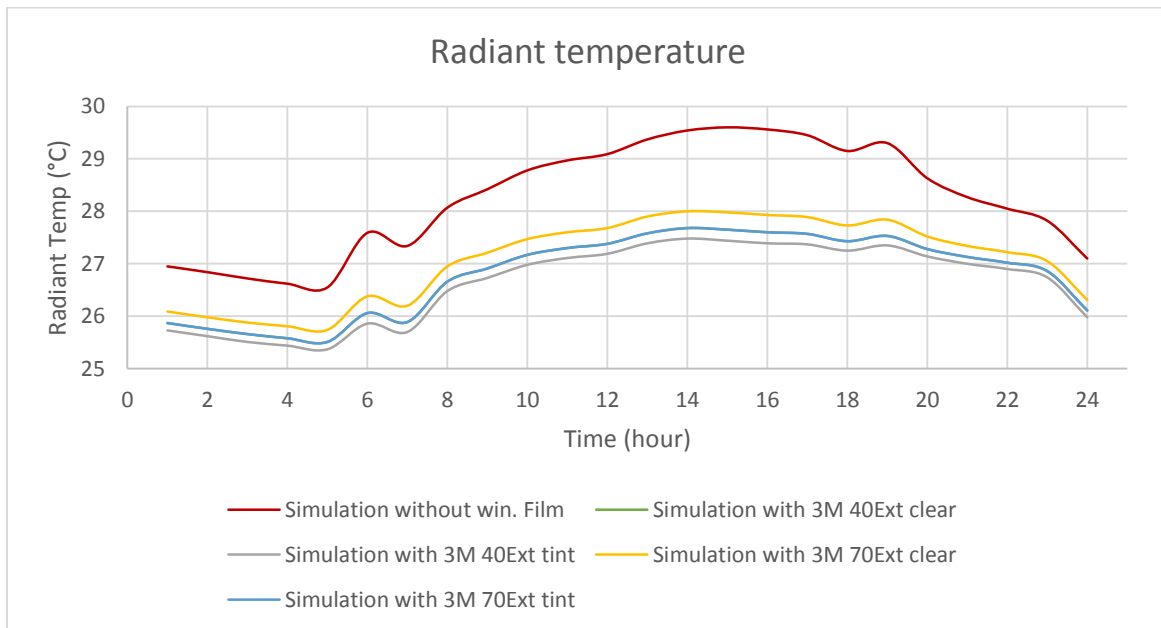

Figure 6.7: Impact of window films on the radiant temperature on a typical hot sunny summer day

Figure 6.7 illustrates the result of the radiant temperature of a sample zone of the hotel on a typical hot sunny summer day. This result was presented to evaluate one of the benefits of the window films associated with their potential of improving the perception of internal thermal comfort of the building by the reduction of solar radiant heat gain. The sample zone selected is the ground floor restaurant area, as it is a social hub in the case study hotel and the restaurant is next to the large window areas of the single glazed façade, hence it is directly exposed to the solar radiation and heat gain through the windows. From figure 6.7, it can be observed the application of the window films largely reduced the radiant temperature of the zone especially during the afternoon period when the solar radiation is higher. Moreover, the maximum reduction in radiant temperature of approximately 7% was observed for window film (3M 40 EXT) applied to clear and tinted windows and a reduction in the maximum radiant temperature of approximately 6% for window film (3M 70 EXT) applied to clear and tinted windows.

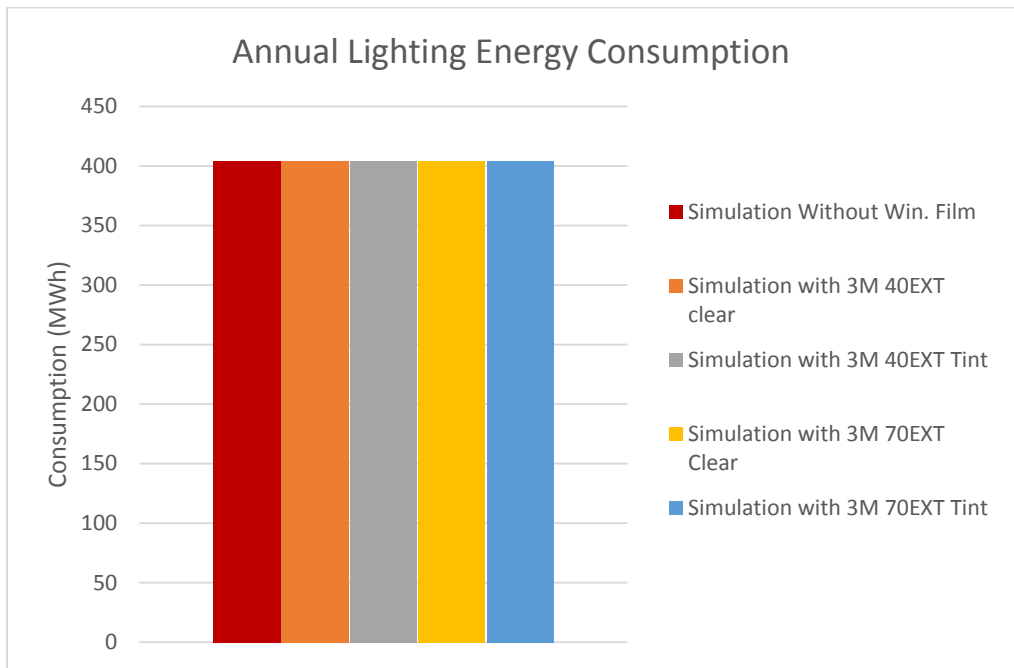
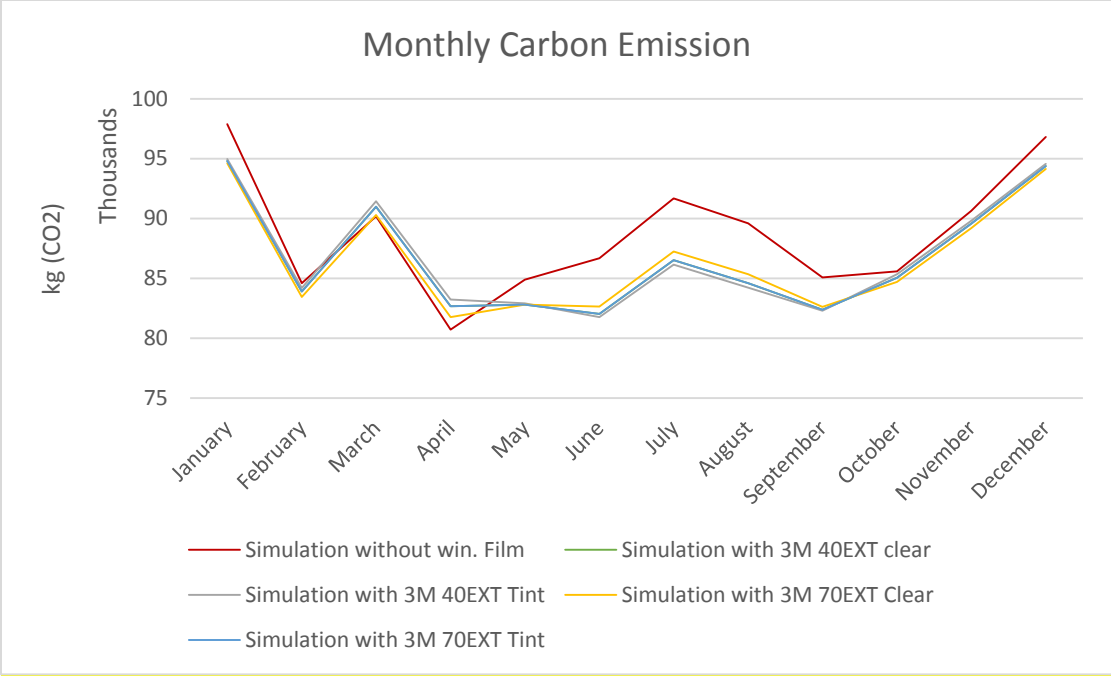

Figure 6.8: Impact of window films on overall lighting energy consumption

From figure 6.8 showing the impact of the window films on the overall lighting energy consumption, it can be noted that the films have no noticeable impact. This is mainly due to the depth of rooms and social spaces, especially since daylight provided in a zone is limited to the perimeter areas of the building. Moreover, zones such as the bed rooms are less occupied during the peak of the daylight period when light transmission is at its highest. Also, the virtually clear visual characteristics of the films offers relatively good light transmission through them.

Therefore, to further aid in the choice of appropriate window films, it is insightful to investigate the impact of the window films on additional parameters such as energy cost and CO₂ emissions. Since the factor and price rate used to evaluate energy cost and CO₂ emissions resulting from natural gas and grid electricity are different, this investigation can demonstrate whether the window films have a more favourable impact on energy cost and CO₂ emissions. The CO₂ conversion factors of 0.184 for natural gas and 0.281 for grid supplied electricity used for this analysis was obtained from the UK Government GHG Conversion Factors for company reporting spread sheet 2018 (BEIS, 2018b). Conversion factors from this source was used as the spread sheet provides GHG conversion factors that are suitable for use by organisations of all sizes based in the UK and international organisations reporting on their UK operations (BEIS, 2018b). The Department for Business, Energy and Industrial Strategy provide and update this GHG conversion factors spreadsheet annually and this current 2018 version is valid till July 2019. The tariff rate of £0.059 per kWh for electricity and £0.03 per kWh for natural gas used in the cost analysis was obtained from the case study building energy supply data.

The result of the impact of the window films on the energy cost and CO₂ emissions is presented in Figures 6.9 to 6.12:



(a) Monthly CO₂ emissions result

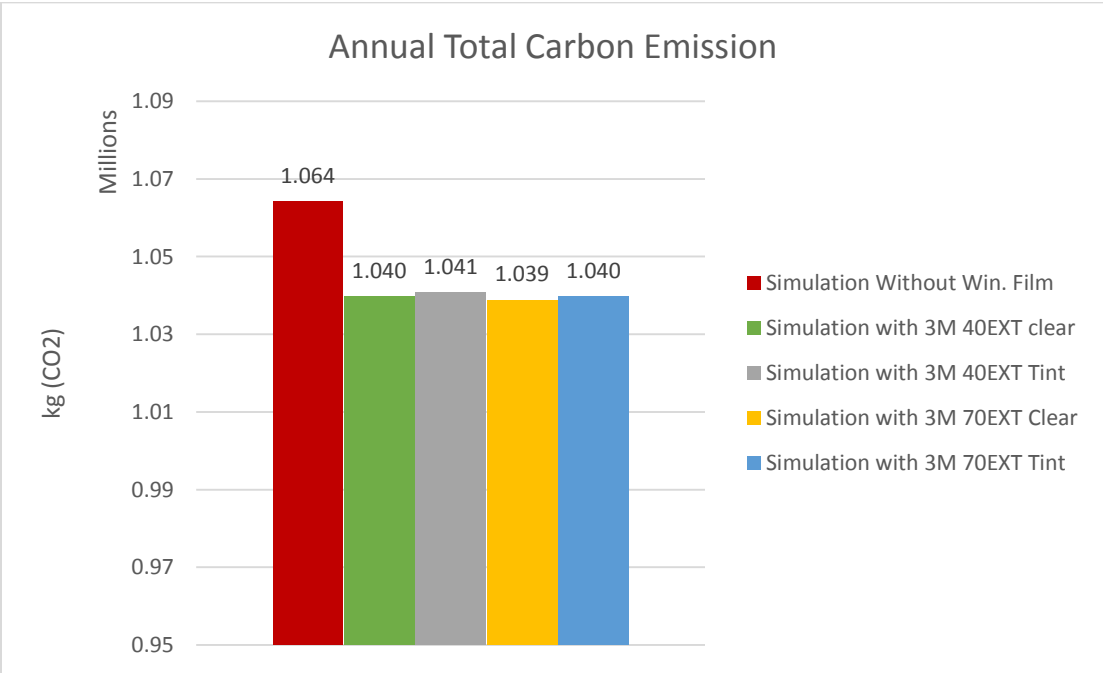

(b) Annual overall CO₂ emissions result

Figure 6.9: Impact of window films on CO₂ emissions

From Figure 6.9(a), which illustrates the monthly CO₂ emissions result, it can be observed that there is a reduction in the CO₂ emissions due to the application of the window films. The figure shows that the bulk of the CO₂ emission reduction occurs during the cooling dominant period, this is because of the reduction in cooling energy consumption due to the impact of the window films. Moreover, CO₂ emissions reduction resulting from cooling demand reduction is worth more in terms of kg as this is driven by a reduction in electricity consumption. The peak reduction in CO₂ emissions was observed around the peak of the summer in July. The maximum percentage reduction in CO₂ emissions of 6% for window film (3M 40 EXT) applied to clear and tinted windows while a maximum percentage reduction of 5% and 6% was observed for window film (3M 70 EXT) applied to clear and tinted windows.

Figure 6.9(b), showing the annual overall CO₂ emissions results, also exhibits a similar trend to that observed in Figure 6.9(a). The figure shows that the percentage overall CO₂ emission reduction across the year is not huge, with a total annual CO₂ emission reduction of approximately 2% observed for window films (3M 40 EXT) and (3M 70 EXT) applied to clear and tinted windows.

Figures 6.10 to 6.12 present the result for the cost analysis due to the impact of the window films.

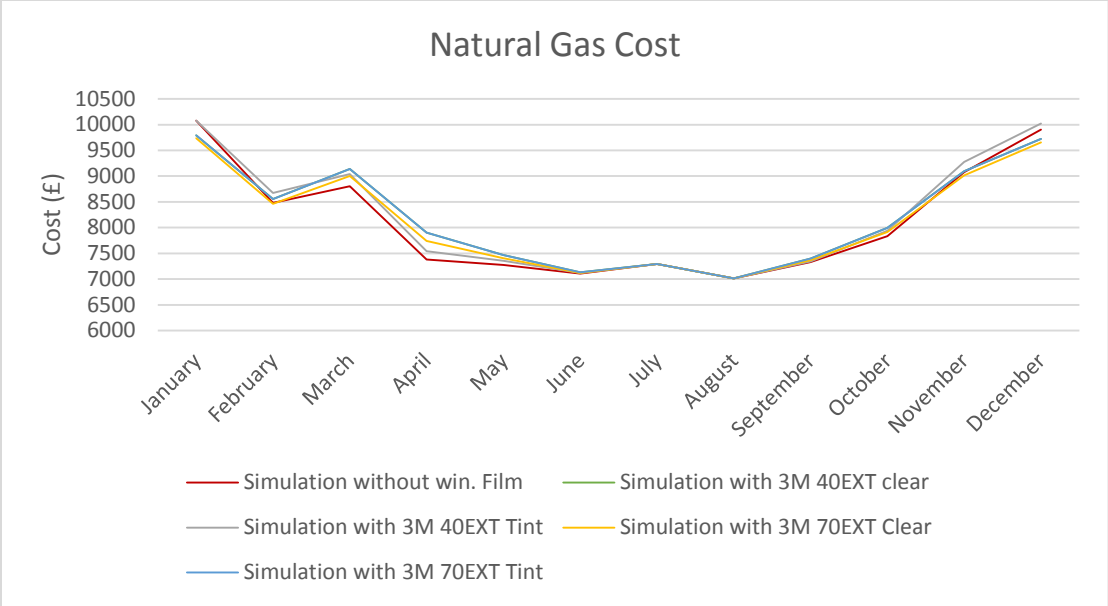

(a) Monthly Natural gas cost result

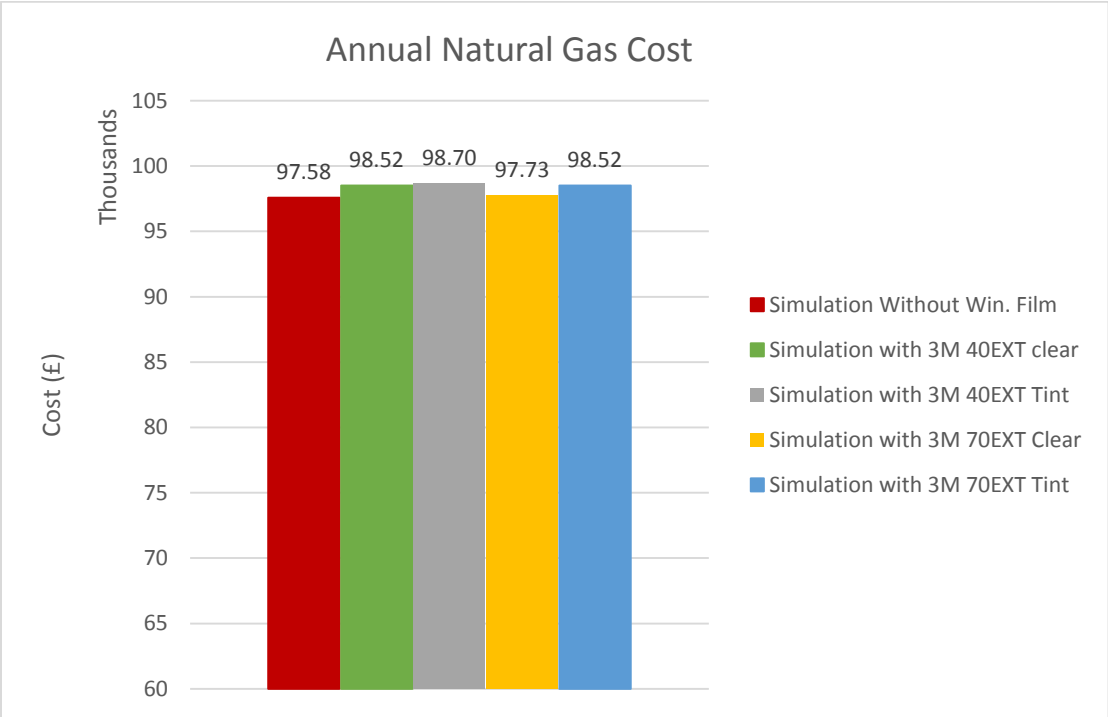

(b) Annual natural gas cost result

Figure 6.10: Impact of window films on natural gas cost

From Figure 6.10(a), showing the result of monthly cost of natural gas, it can be observed that there is a small increase in the cost of natural gas, especially during the heating dominant period. This can be attributed to the increase in heating energy demand observed during the heating season. The peak percentage increase in the cost of natural gas of up to 7% and 2% was observed for window film (3M 40 EXT) applied to clear and tinted windows and a peak percentage increase of 5% and 7% was observed for window film (3M 70 EXT) applied to clear and tinted windows. Although Figure 6.10(b), which illustrates the total annual cost for natural gas demonstrates a similar trend of increase in natural gas cost, the overall percentage increase was marginal. The percentage increase of approximately 1% was observed for window film (3M 40 EXT) applied to both clear and tinted windows, while there was no overall increase in natural gas cost for window film (3M 70 EXT) applied to both clear and tinted windows.

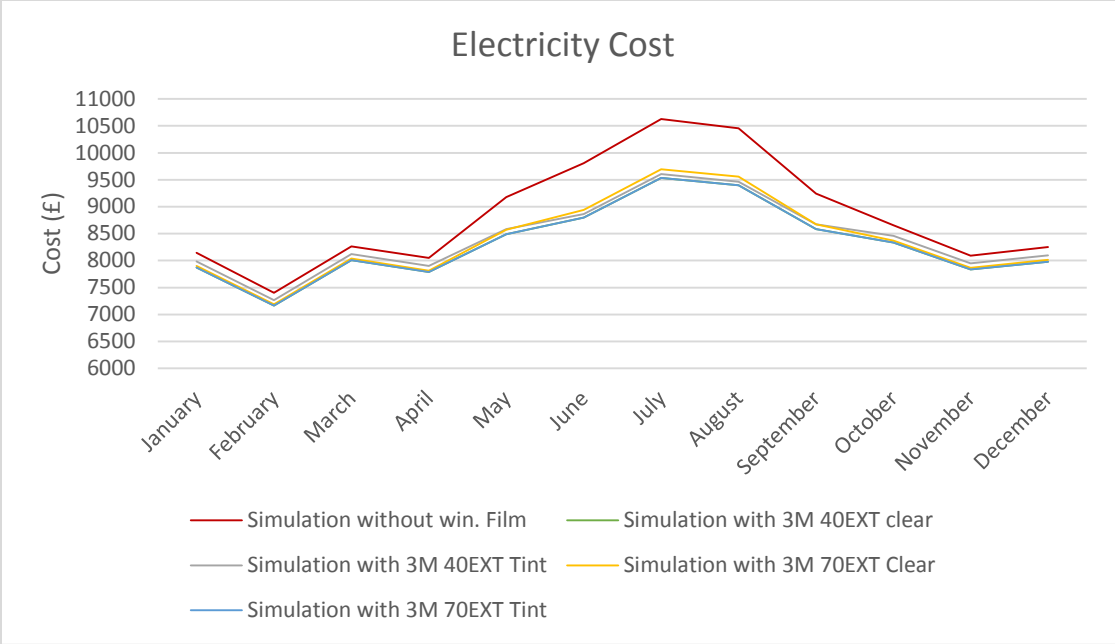

(a) Monthly Electricity cost result

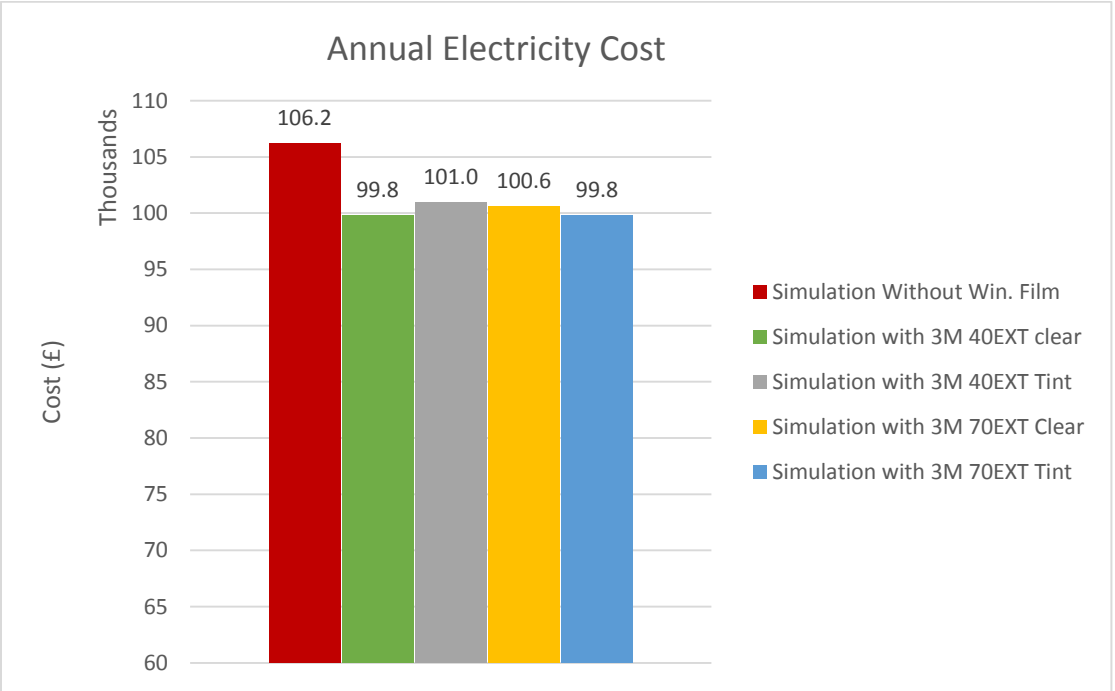

(b) Annual electricity cost result

Figure 6.11: Impact of window films on electricity cost

From Figure 6.11(a), presenting the result of the monthly cost of electricity, it can be seen that there is a considerable reduction in electricity cost for window films. This reduction is due to the decrease in cooling energy demand and consumption observed during the cooling summer period because of the impact of the window films. Figure 6.11(b) showing the overall annual electricity cost exhibits a similar trend to that observed in Figure 6.11(a). A percentage reduction in the overall annual electricity cost of 6% and 5% was observed for window film (3M 40 EXT) applied to clear and tinted windows and there was a reduction of 5% and 6% in electricity cost for window film (3M 70 EXT) applied to clear and tinted windows.

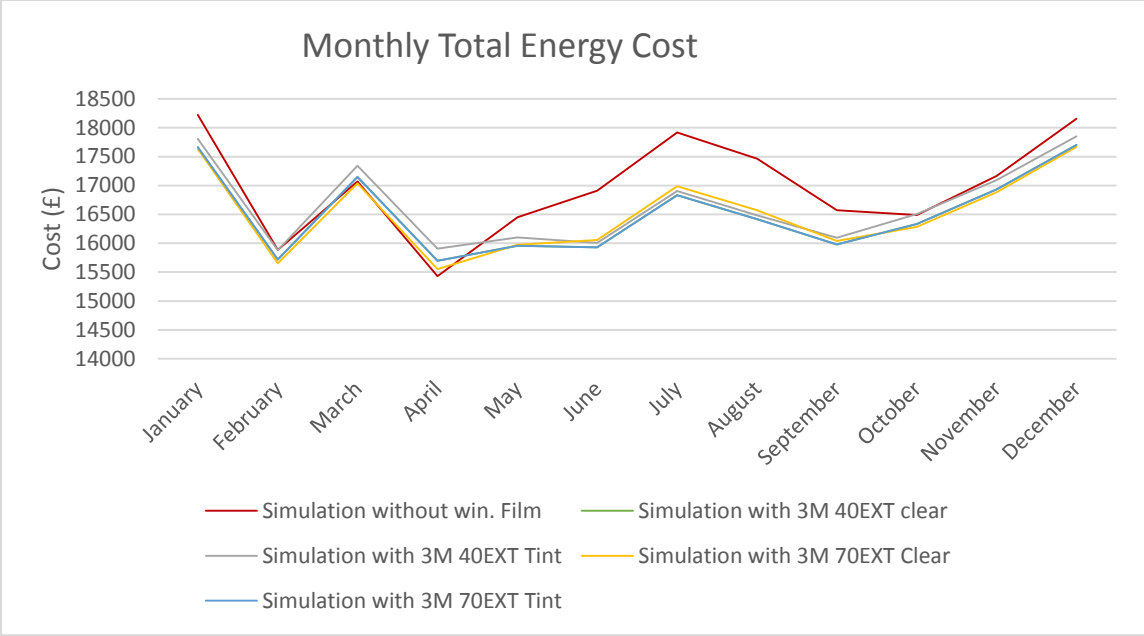

(a) Monthly overall energy cost result

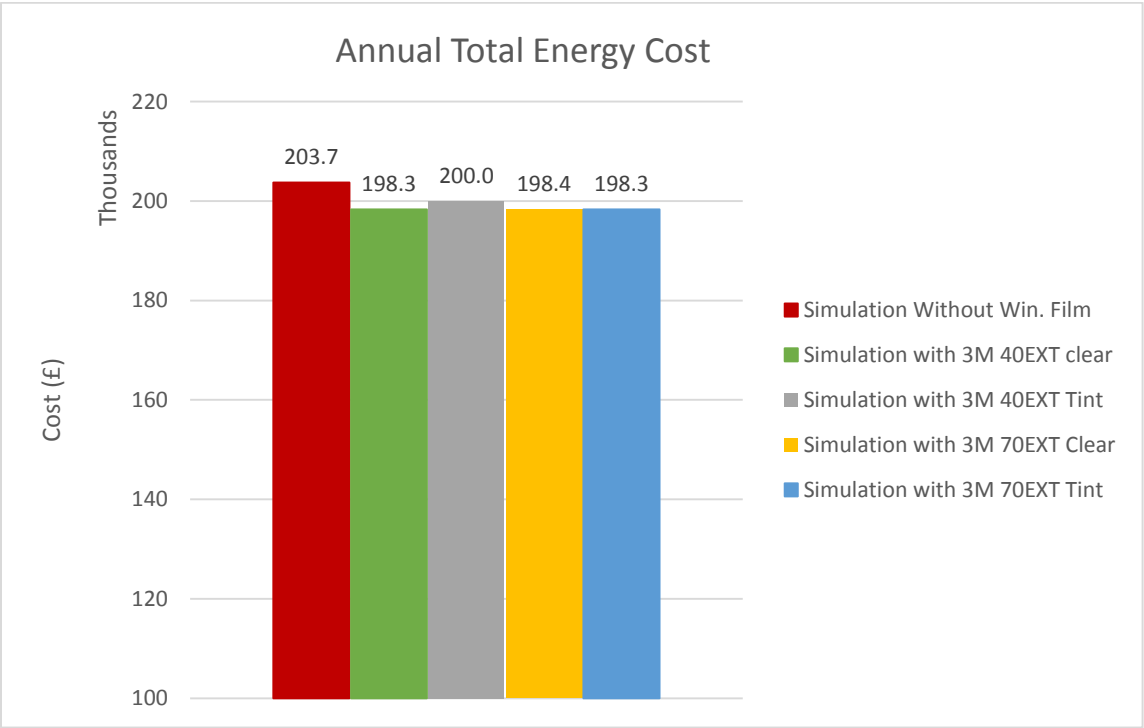

(b) Annual total energy cost result

Figure 6.12: Impact of window films on overall energy cost

From Figure 6.12(a), showing the monthly overall energy cost due to the impact of the window films, it can be observed that there is a reduction in the overall energy cost during the cooling dominant period and a marginal increase during the heating season. This is because the marginal reduction in energy cost during the summer is countered by a similar marginal increase in energy cost. The maximum percentage reduction in energy cost of 6% and 5% was observed for window film (3M 40EXT) applied to clear and tinted windows and a maximum percentage reduction of 5% and 6% was observed for window film (3M 70EXT) applied to clear and tinted window. In Figure 6.12(b), showing the annual total energy cost due to the impact of the window films, it can be observed that there is a reduction in the overall annual energy cost. The percentage reduction in total energy cost of 3% was observed for window film (3M 40EXT) applied to a clear window and window film (3M 70EXT) applied to both clear and tinted window. While the percentage reduction in total energy cost of 2% was observed for window film for (3M 40EXT) applied to tinted windows.

Table 6.3: Summary table showing percentage difference between simulation result without window film compared to simulation result incorporating window films on all orientation

Window films	Heating energy consumption (%)	Cooling energy consumption (%)	Total energy consumption (%)	Gas CO ₂ emissions (%)	Electricity CO ₂ emissions (%)	Total CO ₂ emissions (%)	Electricity cost (%)	Total energy cost (%)
3M 40EXT clear	-1.3	32	1.9	-1	6	2	6	3
3M 40EXT tint	-2	35	1.6	-1	5	2	5	0
3M 70EXT clear	-0.2	28	2.1	-0.5	5	2	5	3
3M 70EXT tint	-1.3	32	1.9	-1	6	2	6	3

Note: (- Negative) is percentage increase; (+ Positive) is percentage decrease.

Table 6.6 shows the summary of results of the percentage difference between the simulation model without the window film compared to the one incorporating the window films for key energy performance parameters. It can be observed that window films (3M 40EXT) and (3M 70EXT) window films applied to both clear and tinted windows provide relatively similar performance. Therefore, the choice of window film for this case study building can be made between these two window films with a preference depending on whether the less clear window film is required for privacy considerations. Savings in electricity cost is one key parameter that can be used to select appropriate window film since the price rate and emission factor for electricity is higher than that of gas.

6.4.2 Case study result for Hilton Reading Hotel with window films on different orientations of the building

Since the impact of the window films applied to the building, irrespective of the orientation of the window, is not huge, it could be more economical to investigate the impact of the window films on energy performance, with the window films applied to windows facing a different orientation of the building. Figure 6.13 shows a typical 2D plan of the model showing the orientation of the building:

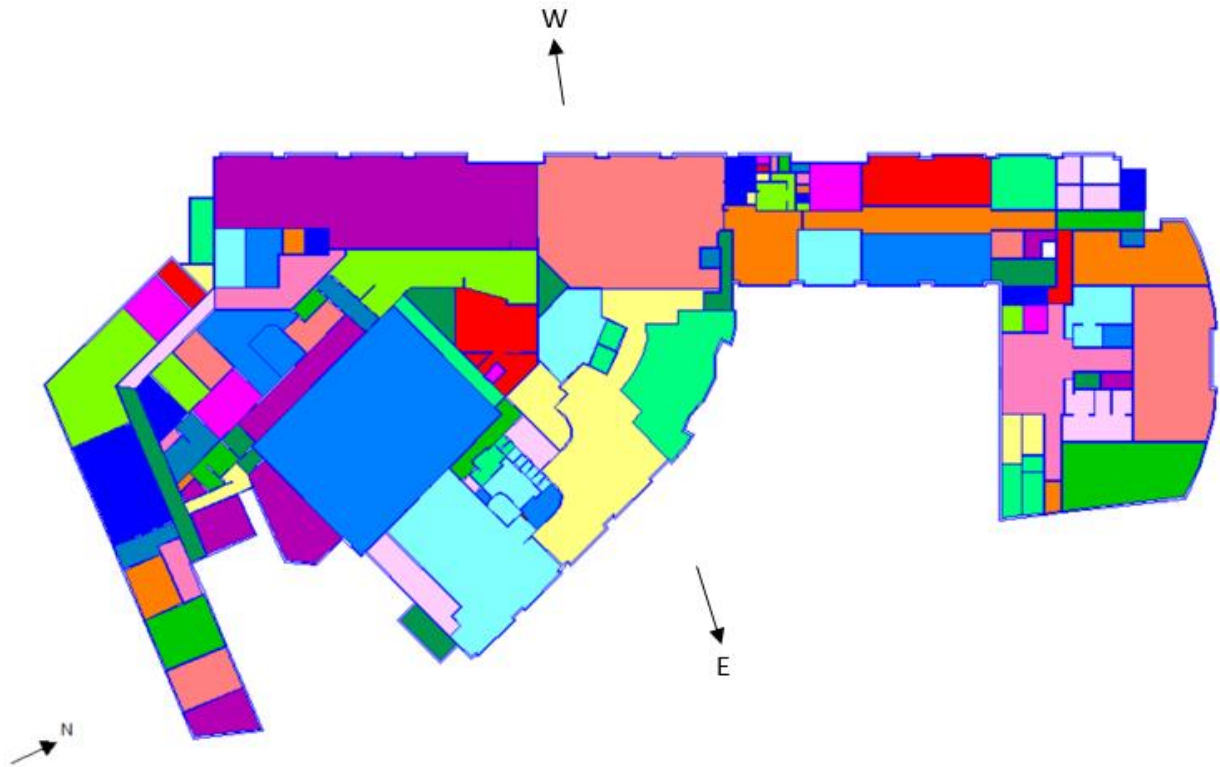
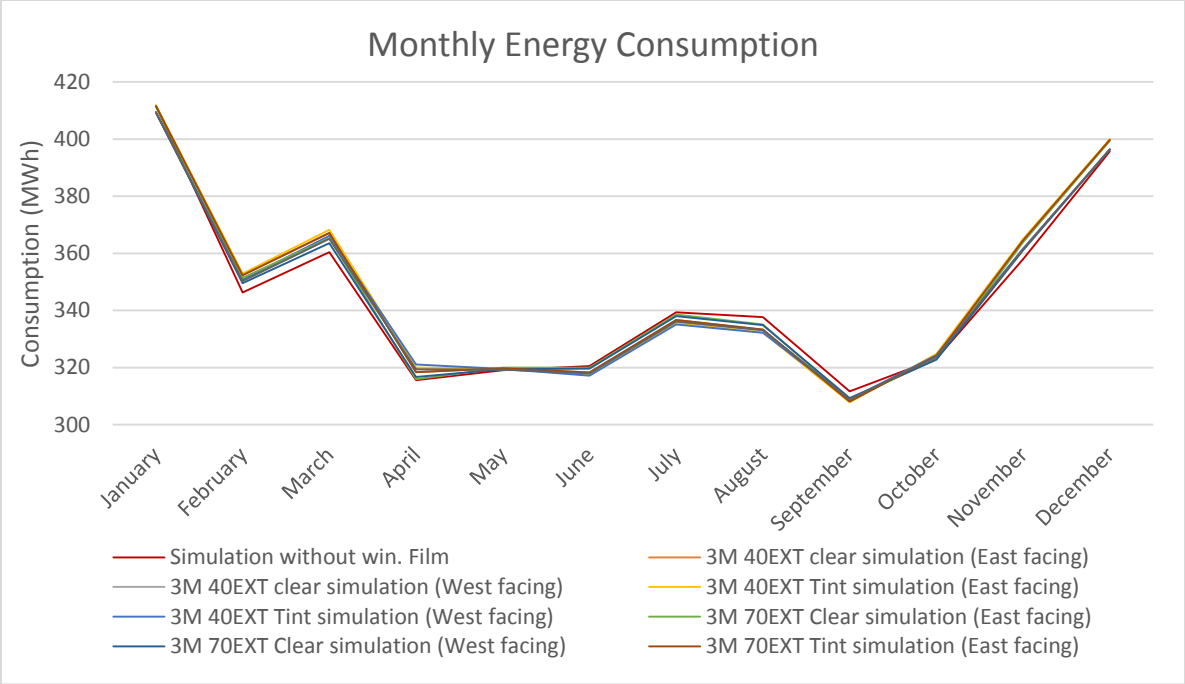
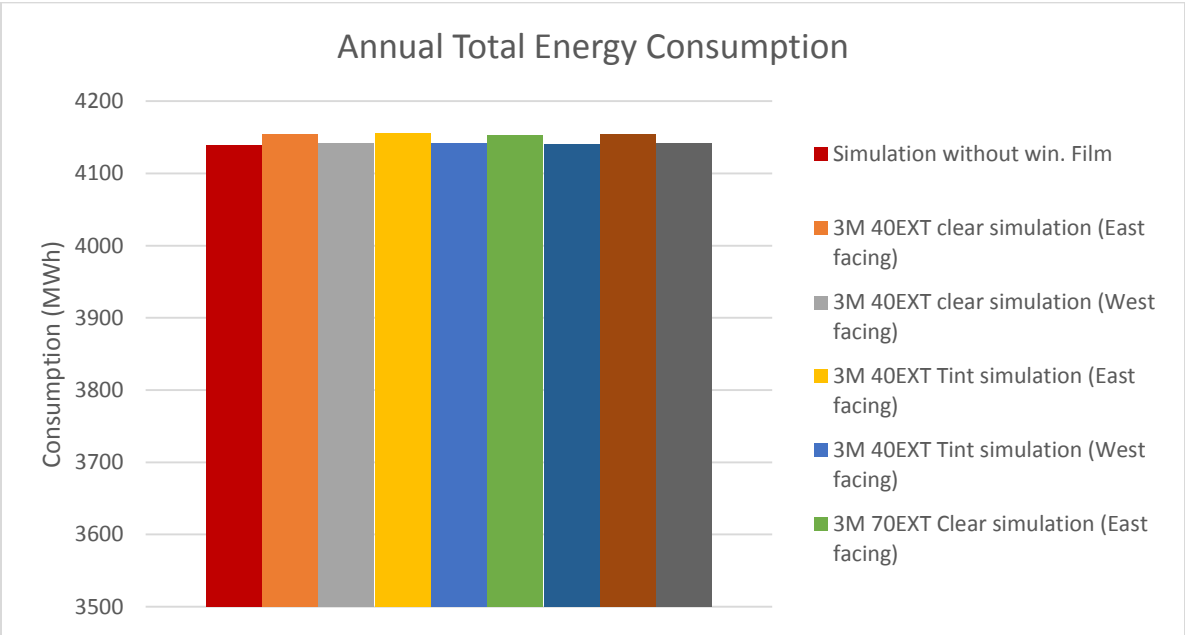

Figure 6.13: Typical floor plan showing zone allocation and building orientation

The result of the impact of window films applied to the east or west facing windows of the building on the energy consumption is presented in Figures 6.14.



(a) Monthly energy consumption result



(b) Annual total energy consumption result

Figure 6.14: Impact of window films applied to the east or west facing windows on the overall energy consumption.

From Figure 6.14 showing the result of the total energy consumption for model simulation incorporating window films to either the East or West facing windows, it can be observed that there is no visible reduction in the total energy consumption due to the application of the window films. Figure 6.14(b) demonstrate that there is no increase nor decrease in the total energy consumption for all the window films when applied to the West facing windows only, whereas there is a very small percentage increase of 0.4% for all the window films when applied to the East facing windows.

Analysis of the simulation result for the window films installed to either the East or West facing windows have shown that it has no positive impact on the overall energy consumption. And due to the design of the building having more than 90% of its windows to the East and the West, it is insignificant installing the window films on the North and South facing windows only. Therefore, installing the films on windows facing different orientations, is not an economical alternative to having the window films on all the windows irrespective of orientation.

6.5 Results and Discussion for Impact of Window Films on Hilton London

Heathrow Airport Terminal 4 (Conventional framed structure and Wall)

The results and discussion of results for the Hilton London Heathrow Airport Terminal 4 hotel which is a conventional framed structure and wall building is presented in this section. Preceding section 4.4.2 of this thesis presented the results and discussion of results for the first stage of this case study building (Hilton London Heathrow Airport Terminal 4 hotel) which involves estimation and validation of the case study building the energy consumption (that is the base model without window film).

6.5.1 Case study result with window films on all orientation of the building

The next stage of the analysis involves the simulation of the building incorporating the window films on all orientation of the model. Figures 6.15 to 6.19 present the results for this stage.

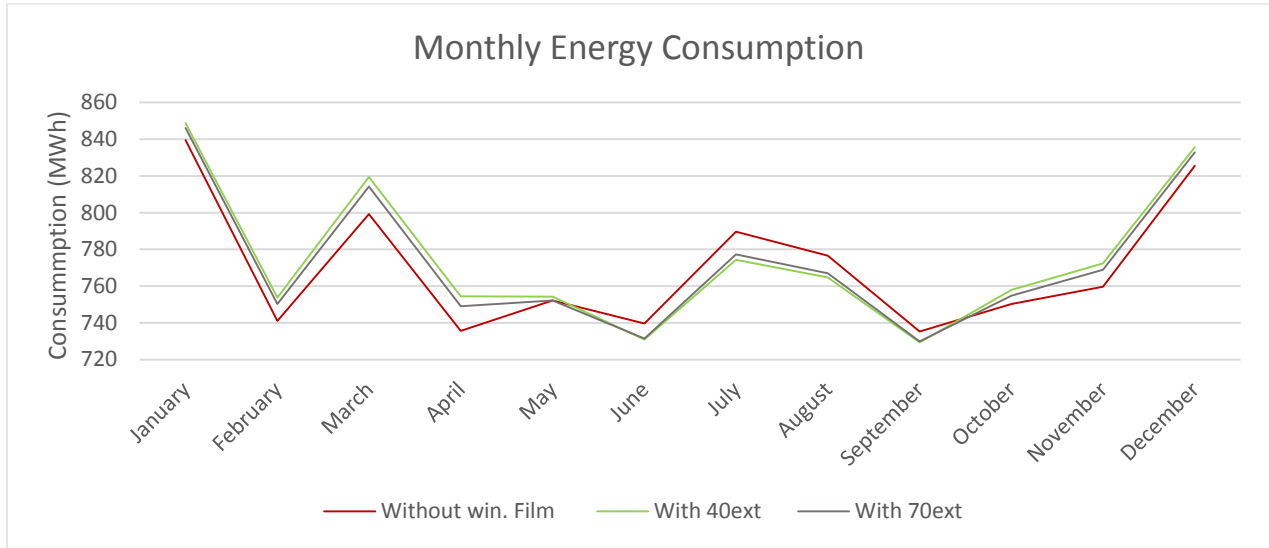

(a) Monthly total energy consumption result

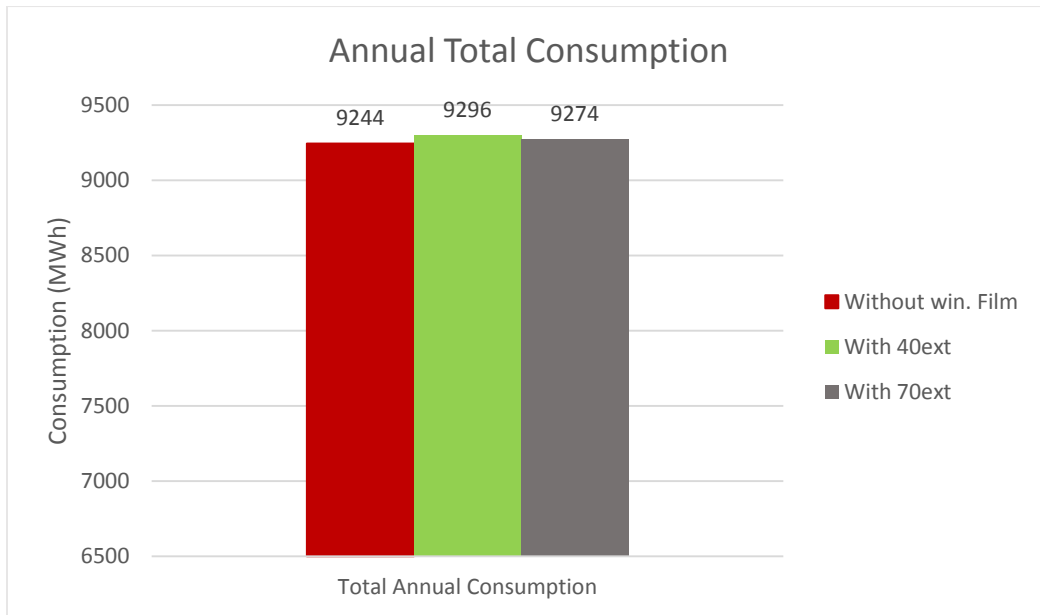

(b) Annual overall energy consumption result

Figure 6.15: Simulation overall energy consumption results (Hilton London Heathrow)

Figure 6.15 shows the total energy consumption result for the simulation examining the effect of the window films compared to the base model without the window films. From Figure 6.15(a), it can be noted that there is a marginal saving in energy consumption due to the application of the window films occurring mainly during the cooling dominant period. However, there is a corresponding increase in the monthly energy consumption during the longer heating period dominant period. Hence, from Figure 6.15(b), it can be observed that there is a marginal increase in total annual energy consumption for the simulation, unlike the reduction in total energy consumption observed for the glazed curtain wall of the Hilton Reading Hotel. From the figure, marginal percentage increase of 0.6% to 0.3% for window films (3M 40EXT) and (3M 70EXT) respectively.

Whilst the impact of the window film on the overall energy consumption for this building is not positive it is insightful to investigate the effect of the window films on the heating and cooling energy consumption which are the components of the total energy consumption that the window films have direct impact on. Hence, Figures 6.16 and 6.17 present the results of heating and cooling energy consumption:

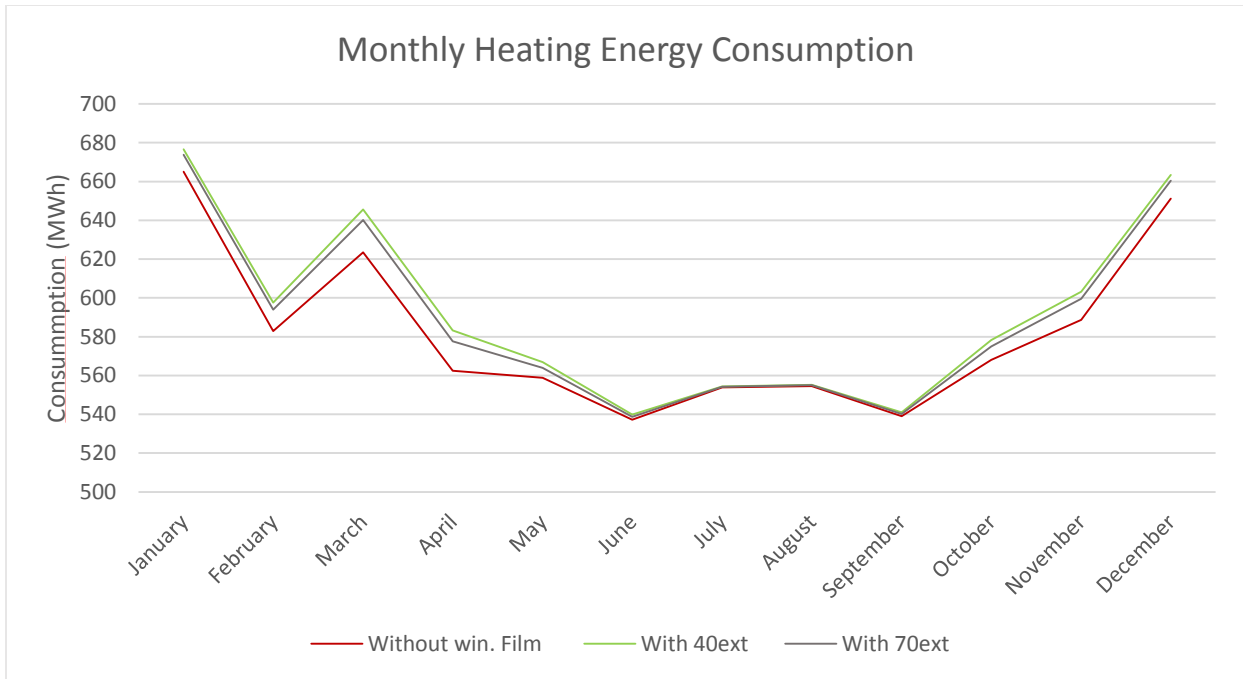

a) Monthly heating energy consumption

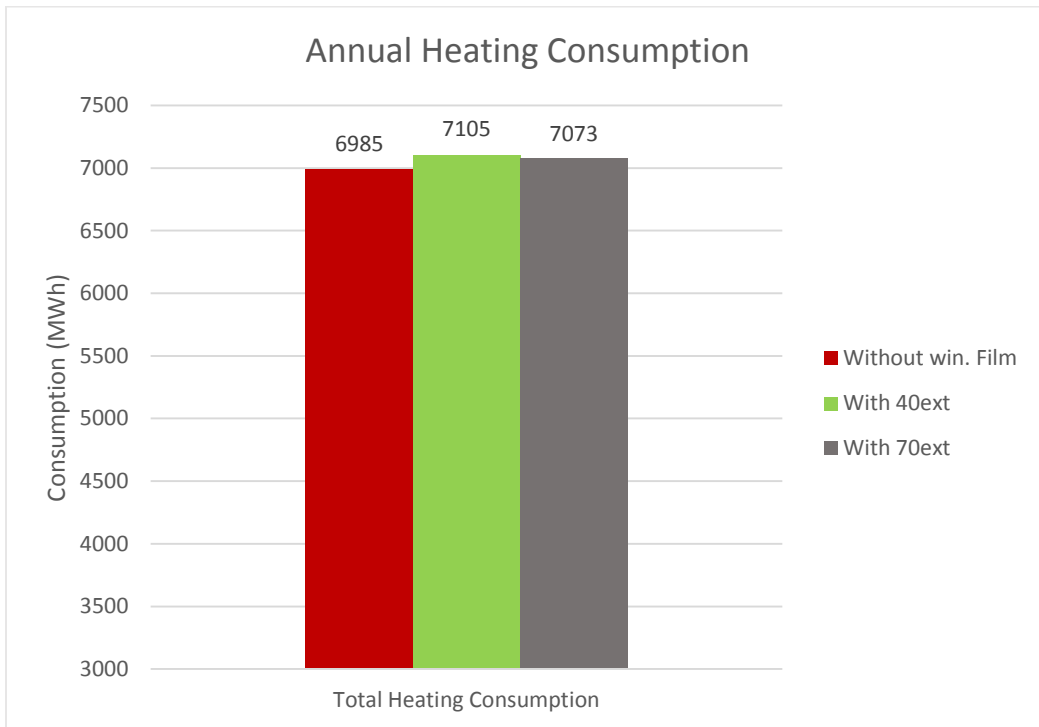

(b) Annual heating energy consumption

Figure 6.16: Impact of window films on heating energy consumption (Hilton London Heathrow)

From Figure 6.16(a), which indicates the monthly heating energy consumption, a similar trend that was observed in the heating energy consumption for the glazed curtain wall building façade of the Hilton Reading Hotel is exhibited. That is, there are no savings in heating energy consumption resulting from the application of the window films. This is so because the window films mainly reduce the amount of solar heat gain through window, which has a negative effect on heating energy use. Moreover, the figure shows an increase in heating energy consumption throughout the year except in July and August during the peak of the summer. Furthermore, from Figure 6.16(b), it can be noted that there is a marginal percentage increase of 1.7% and 1.2% in the annual total heating energy consumption for window films (3M 40EXT) and (3M 70EXT) respectively.

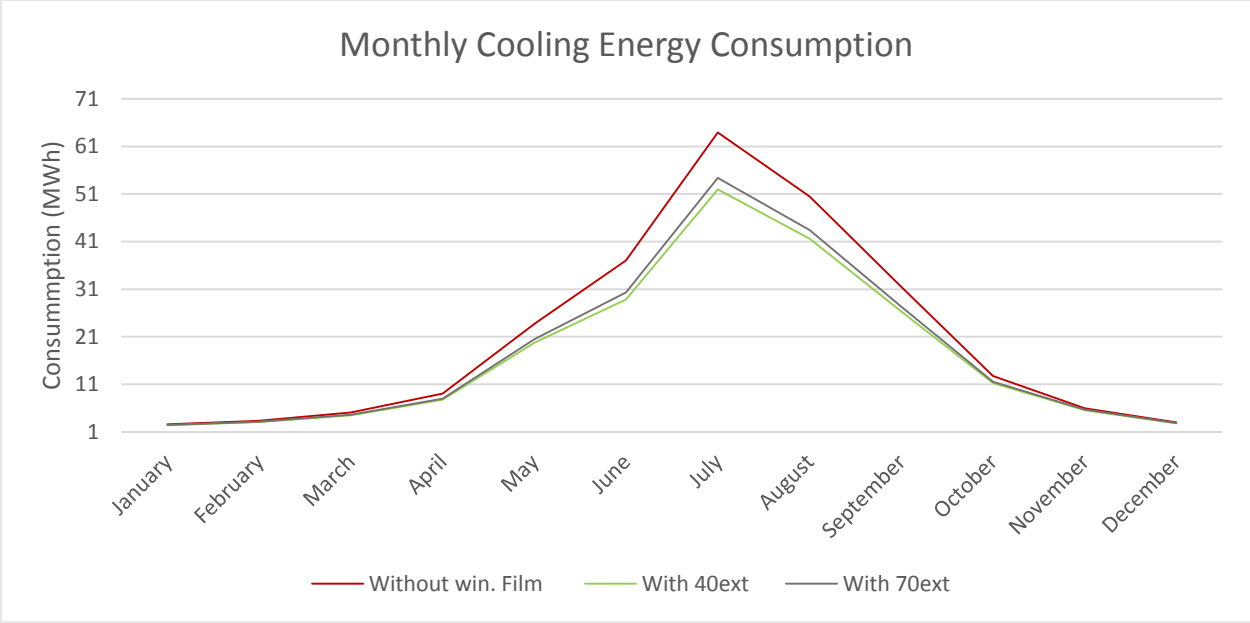

a) Monthly cooling energy consumption

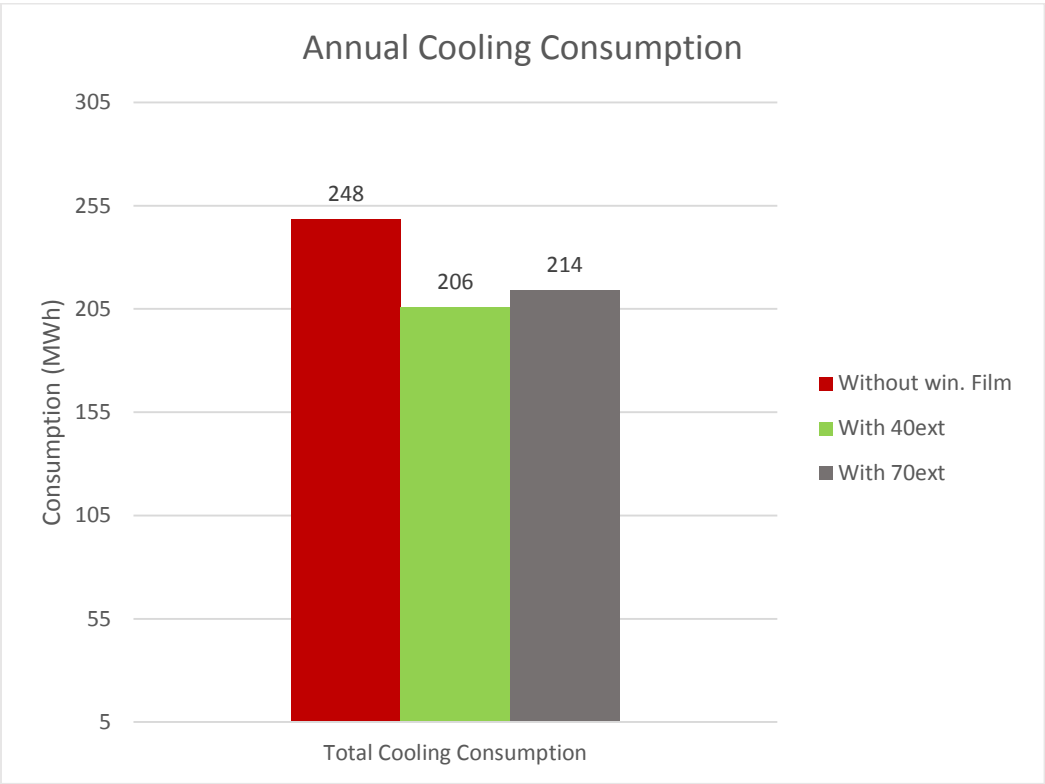

(b) Annual cooling energy consumption

Figure 6.17: Impact of window films on cooling energy consumption (Hilton London Heathrow)

From Figure 6.17, which presents the effect of the window films on the cooling energy consumption, a similar trend that was observed in the cooling energy consumption for the glazed curtain wall building façade of the Hilton Reading Hotel is exhibited. That is, there is significant savings in cooling energy consumption resulting from the application of the window films. However, the reduction in cooling energy consumption observed for the conventional frame structure and wall of the Hilton Heathrow Hotel is notably lower. This is mainly because of the characteristics of the building fabric and façade, which has considerably lower window to wall ratio and transparent areas compared to the glazed curtain wall façade of the Hilton Reading Hotel. For both buildings, the savings in cooling energy consumption can be attributed to the solar heat gain reduction qualities of the window films, which reduce the amount of solar heat gain through the window pane resulting in cooling load reduction during the cooling dominant season.

Hence, from Figure 6.17(a) showing the monthly energy consumption, it can be observed that the bulk of the cooling energy savings is from April to October with the maximum energy consumption reduction occurring in July around the peak of the summer. The maximum percentage cooling energy reduction of 17% and 15% was observed for window films (3M 40EXT) and (3M 70EXT) respectively. Moreover, Figure 6.17(b), which indicates the annual total cooling energy consumption, demonstrates that there is a considerable reduction in the cooling consumption across the year of 17% and 14% for (3M 40EXT) and (3M 70EXT) respectively. However, the annual reduction in cooling energy consumption is lower than the 35% reduction observed with the Hilton Reading Hotel model and is not substantial enough to result in the reduction of overall energy consumption of the building, as evidenced in Figure 6.15(b).

The impact of the window films on additional parameters such as CO₂ emissions and energy cost are presented in 6.18 and 6.19. Since the factor and price rate used to evaluate energy cost and CO₂ emissions resulting from natural gas and grid electricity are different, this investigation can demonstrate whether the window films have a more favorable impact on energy cost and CO₂ emissions. The CO₂ conversion factors of (0.184 for natural gas and 0.281 for grid supplied electricity) used for this analysis were obtained from the UK Government GHG Conversion Factors for company reporting spread sheet 2018 (BEIS, 2018b). The tariff rate of (£0.059 per kWh for electricity and £0.03 per kWh for natural gas) used in the cost analysis was obtained from the case study building energy supply data.

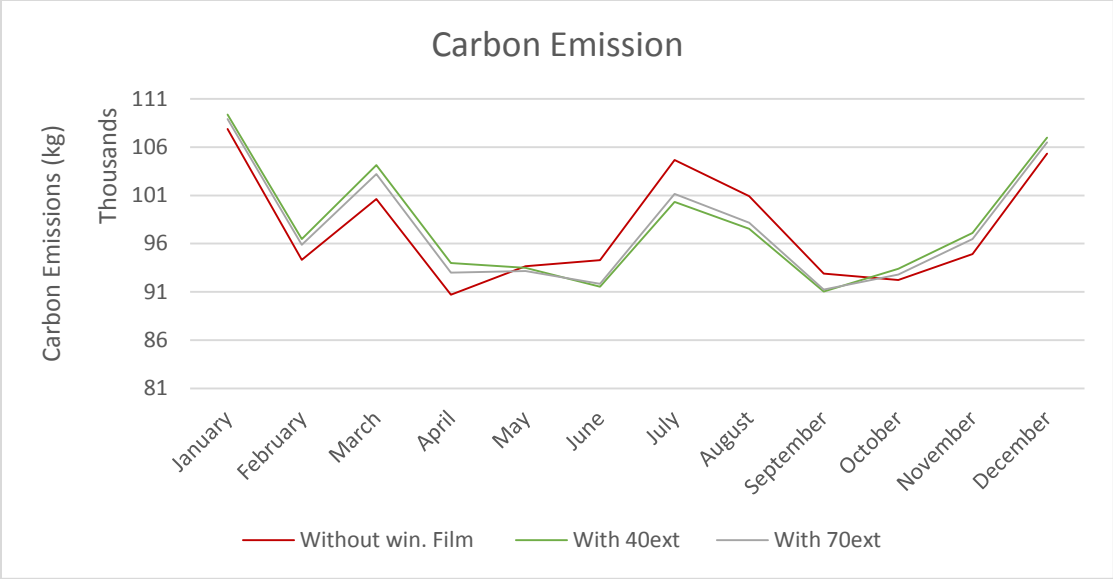

(a) Monthly carbon emission

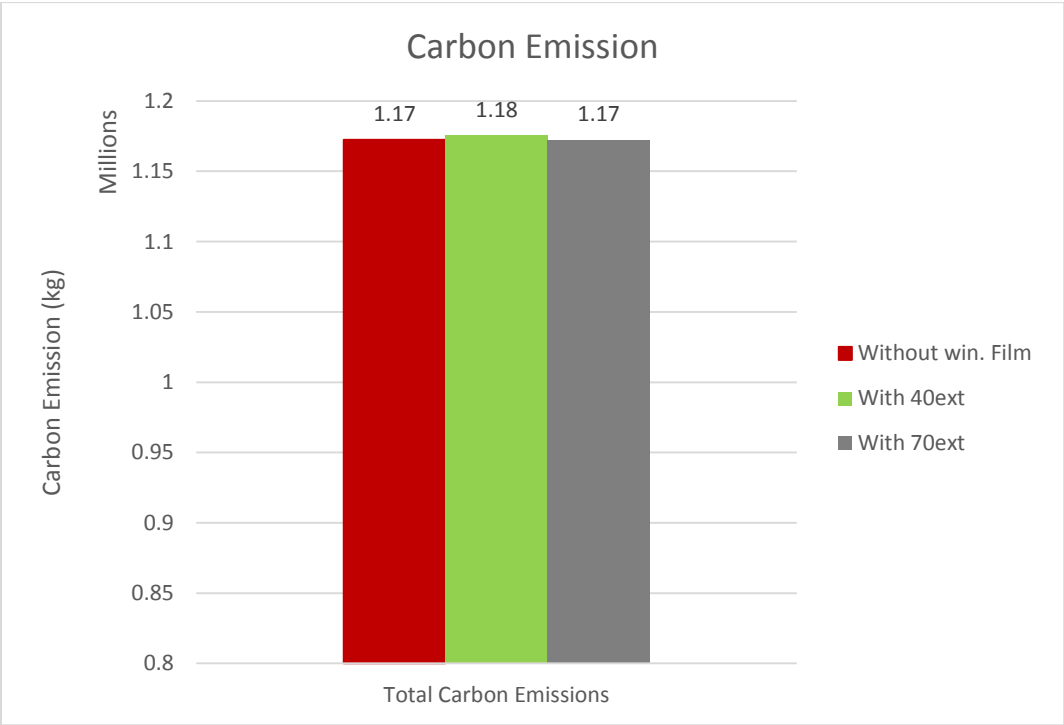

(b) Annual carbon emission

Figure 6.18: Impact of window films on CO2 emissions (Hilton London Heathrow)

From Figure 6.18 presenting the impact of window films on CO₂ emissions, it can be noted that there is no noticeable reduction in the overall CO₂ emissions due to the application of the window films. Since the reduction in the cooling energy consumption resulting from the impact of the window film is mainly during the summer, Figure 6.18(a) shows that the bulk of the CO₂ emission reductions also occur during the cooling dominant period. Furthermore, CO₂ emission reduction resulting from the reduction in cooling demand is worth more in terms of kg as this is driven by a reduction in electricity consumption. From Figure 6.17(b), which shows the annual total CO₂ emissions result, it can be observed that there is a relatively marginal percentage increase in the overall CO₂ emissions across the year. Moreover, this contrasts to the reduction in carbon emissions that observed for the glazed curtain wall building façade of the (Hilton Reading Hotel) due its lower savings in cooling energy consumption. Additionally, the figure shows that there is a marginal total annual CO₂ emission increase of approximately 0.3% observed for window film (3M 40EXT) and no increment or reduction in CO₂ emission for window film (3M 70EXT).

Figure 6.19 presents the results for the cost analysis due to the impact of the window films:

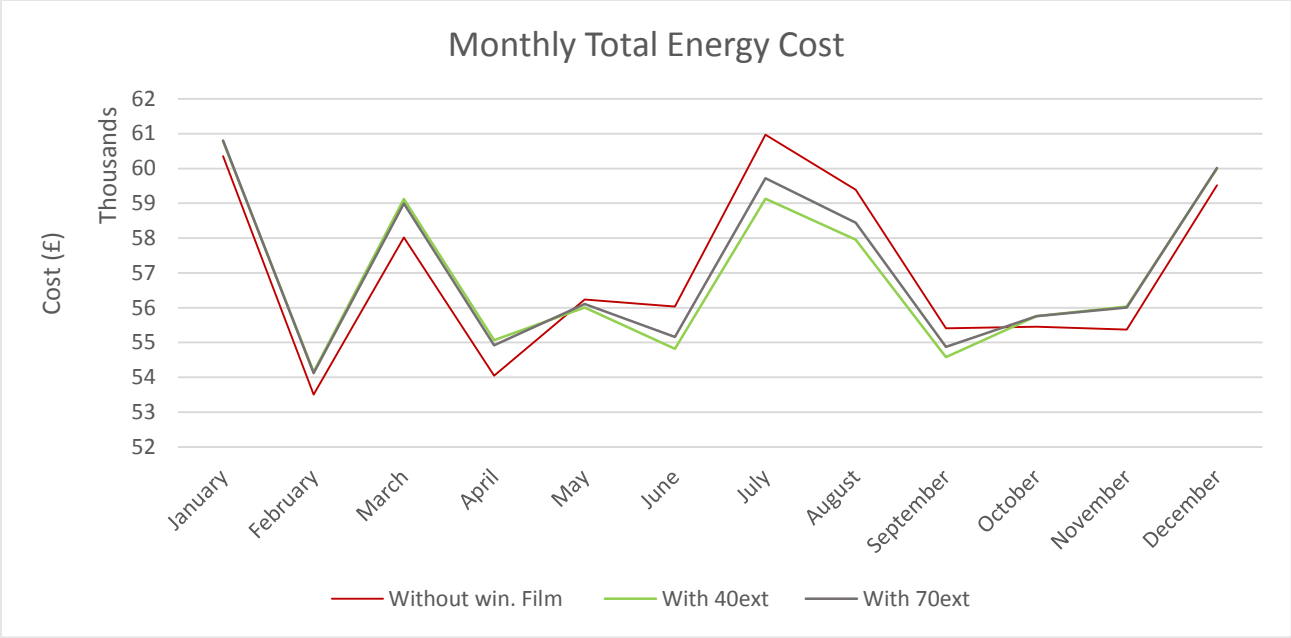

(a) Monthly overall energy cost result

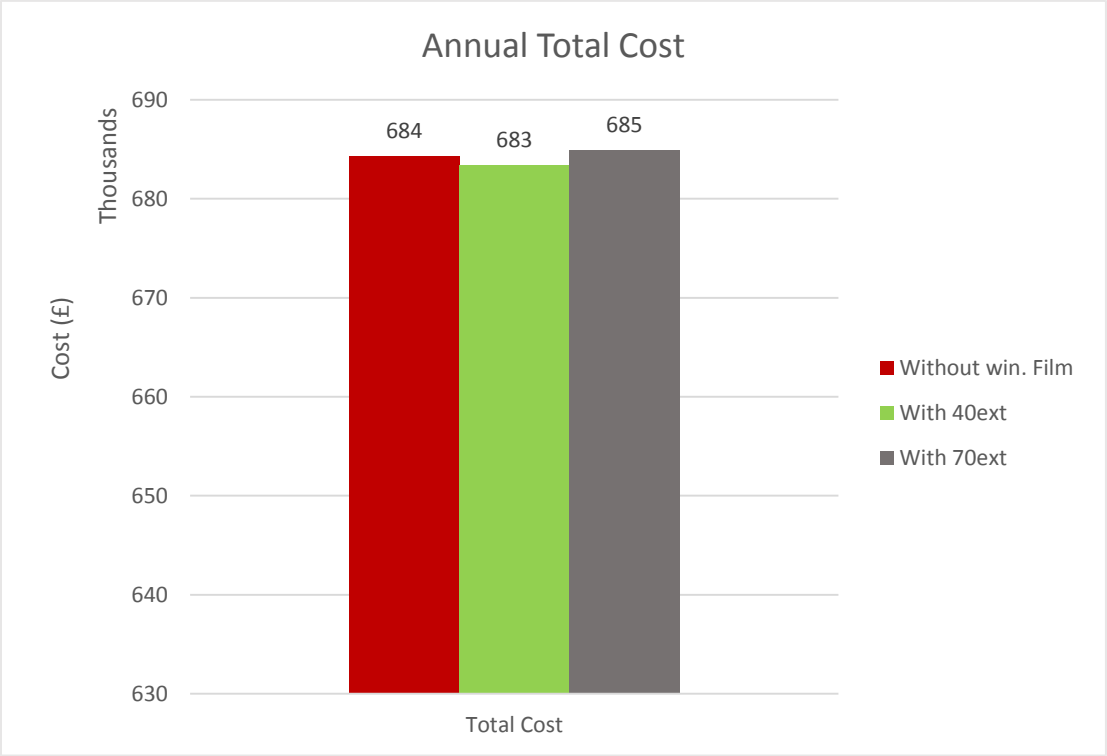

(b) Annual total energy cost result

Figure 6.19: Impact of window films on overall energy cost

From Figure 6.19 indicating the effect of the window films on energy cost, it can be seen that there is approximately no energy saving accruing from their application. This contrasts with the marginal savings in energy consumption observed with the application of the window film for the glazed curtain wall building façade of the Hilton Reading Hotel. However, from Figure 6.18(a) showing the monthly overall energy cost, it can be observed that there is a reduction in the energy cost during the cooling dominant period and an approximately proportional increase during the heating season. The reduction in energy cost observed during the summer is due to the reduction in cooling energy consumption, and this consequently reduces the cost of electricity. In contrast, the witnessed increase in energy cost is associated with the increase in heating energy consumption during the winter period, which consequently increases the cost of natural gas.

Table 6.4: Summary table showing percentage difference between simulation result without window film compared to simulation result incorporating window films on all orientation (Hilton London Heathrow)

Window Films	Heating Energy Consumption (%)	Cooling Energy Consumption (%)	Total Energy Consumption (%)	Total CO ₂ Emissions (%)
3M 40EXT	-1.7	17	-0.6	-0.3
3M 70EXT	-1.2	14	-0.3	0
Note: (– Negative) is percentage increase; (+ Positive) is percentage decrease.				

6.6 Results and Discussion for the Impact of Window Films on Hilton Reading Hotel (Glazed Curtain Wall) Building Model Simulation in Edinburgh

The results presented in preceding sections (6.4 and 6.5) for the Glazed curtain wall and Conventional framed structure and wall building models in the relatively warmer summer climate zone of the UK have indicated that the impact of the window films on the overall energy consumption is not substantial especially for the conventional framed structure and wall building. However, the results have demonstrated that the window films are most beneficial in the reduction of cooling energy consumption during the summer periods. Hence, this section evaluates the impact of the window films on the glazed curtain wall building of the Hilton Reading hotel simulated with the Edinburgh weather condition which is a UK climate zone with relatively colder winter and milder summer. Figure 6.20 to 6.23 illustrate the results of the impact of the window films for the building model simulation in Edinburgh.

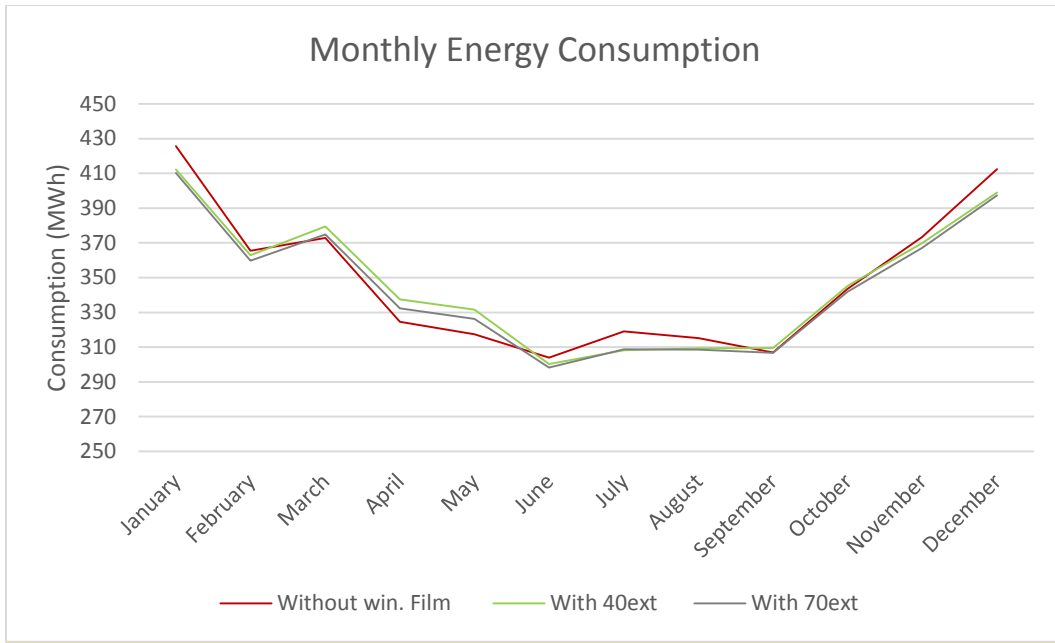

(a) Monthly total energy consumption result

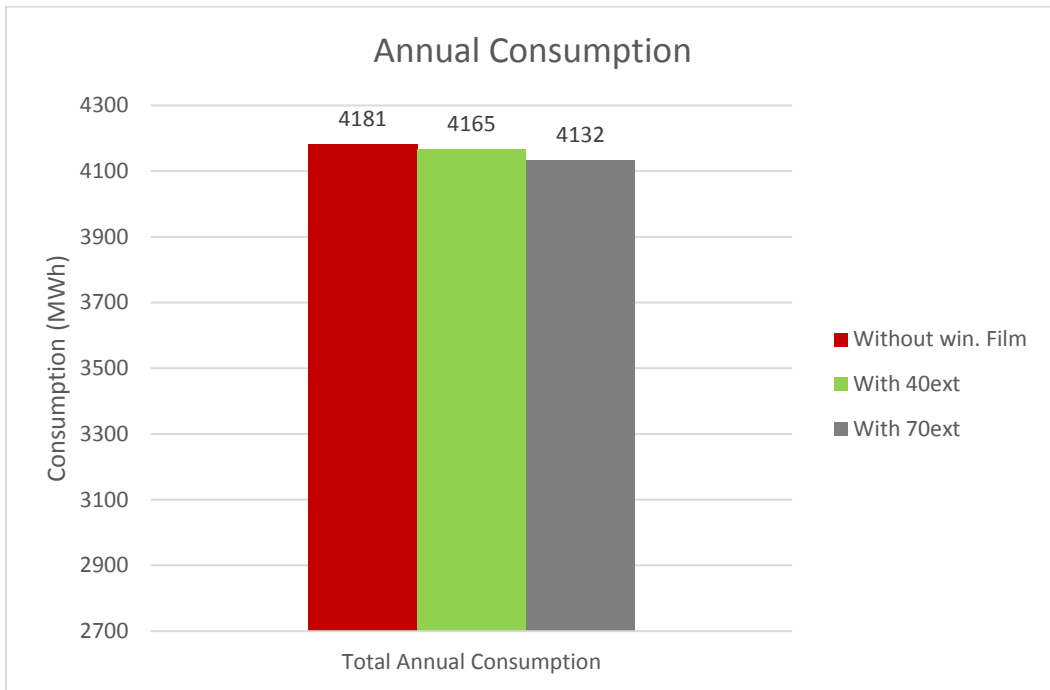

(b) Annual overall energy consumption result

Figure 6.20: Simulation overall energy consumption results (Hilton Reading, Edinburgh simulation)

Figure 6.20 illustrates the total energy consumption result for the simulation examining the effect of the window films compared to the base model without the window films. From Figure 6.20(a), it can be noted that there is a marginal saving in energy consumption due to the application of the window films occurring mainly during the cooling dominant period. However, there is a corresponding increase in the monthly energy consumption during the longer heating dominant season. Therefore, similar to the reduction in total energy consumption observed for the glazed curtain wall of the Hilton Reading Hotel (London simulation), Figure 6.20(b) shows that there is a marginal reduction in total annual energy consumption for the simulation. However, the overall energy reduction for this simulation is even lower than that observed for the London simulation primarily due to the relatively colder winter and milder summer of Edinburgh. From the figure, marginal percentage reduction in total energy consumption of 0.4% and 1.2% for window films (3M 40EXT) and (3M 70EXT) respectively.

Figure 6.21 and 6.22 present the results of the heating and cooling energy consumption to evaluate the impact of the window films on the energy consumption components which the films have direct effect on.

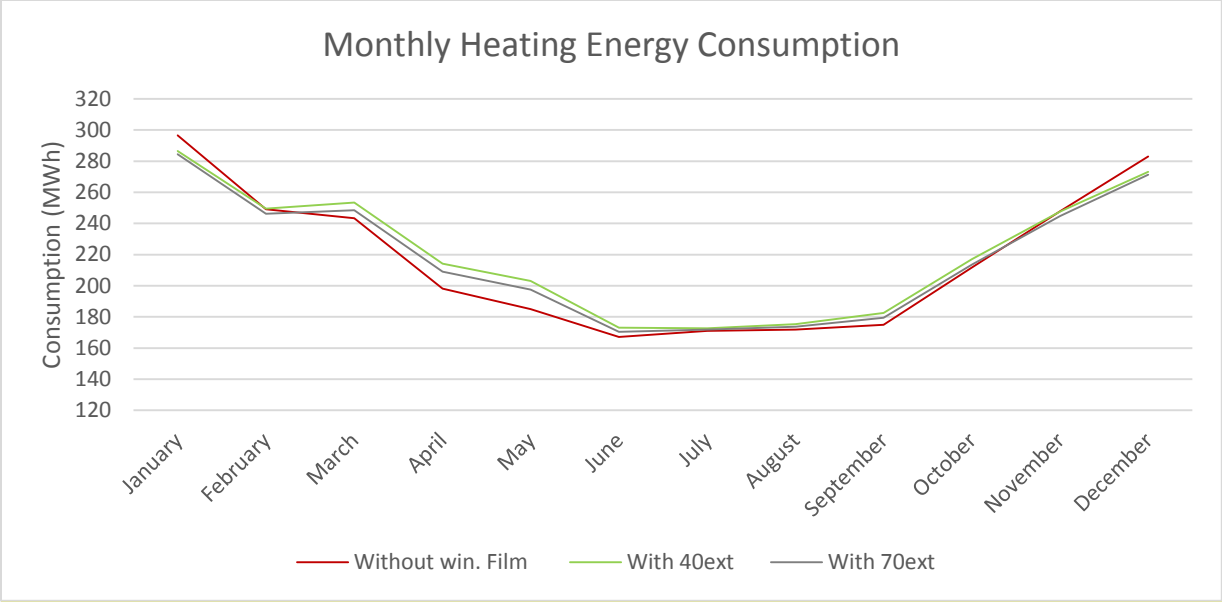

a) Monthly heating energy consumption

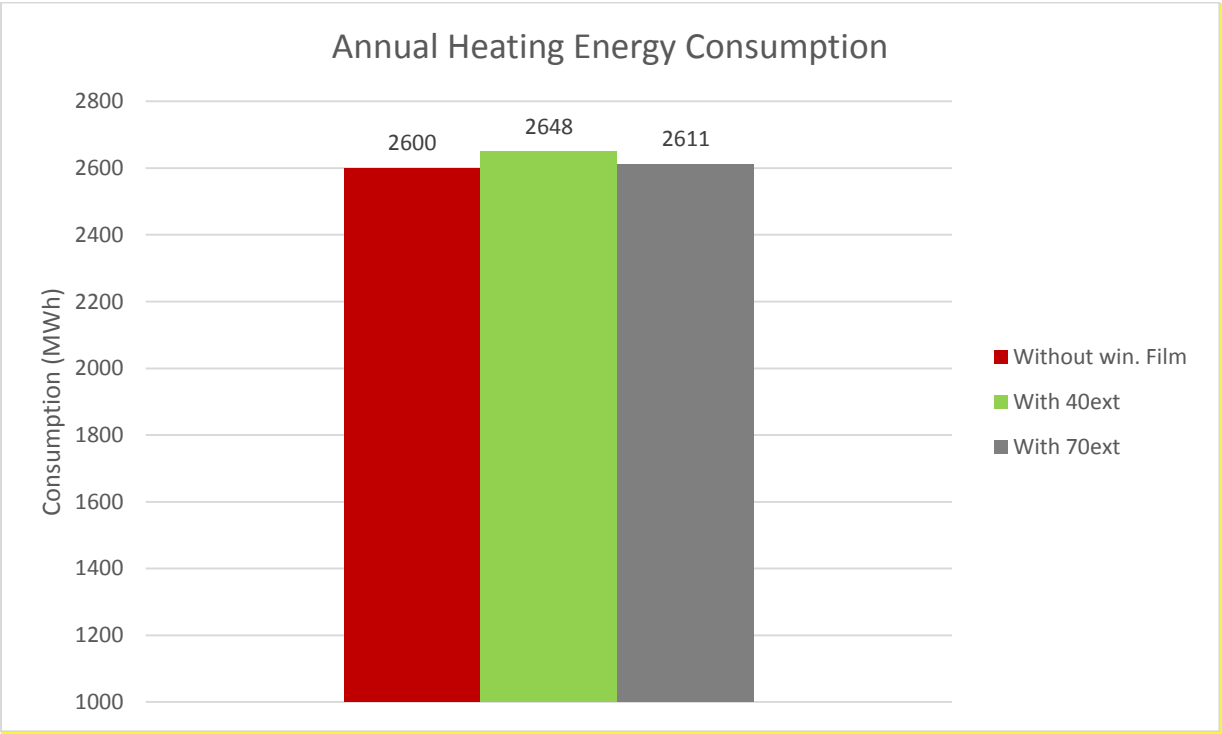

(b) Annual heating energy consumption

Figure 6.21: Impact of window films on heating energy consumption (Hilton Reading, Edinburgh simulation)

From Figure 6.21(a), which shows the monthly heating energy consumption, a similar trend that was observed in the heating energy consumption for the glazed curtain wall building and conventional framed structure and wall of preceding simulation is exhibited. That is, there are no savings in heating energy consumption resulting from the application of the window films. This is so because the window films mainly reduce the amount of solar heat gain through window, which has a negative effect on heating energy use. Besides, the figure shows an increase in heating energy consumption throughout the year except in July and August during the peak of the summer. Additionally, from Figure 6.21(b), it can be noted that there is a marginal percentage increase of 1.8% and 0.4% in the annual total heating energy consumption for window films (3M 40EXT) and (3M 70EXT) respectively.

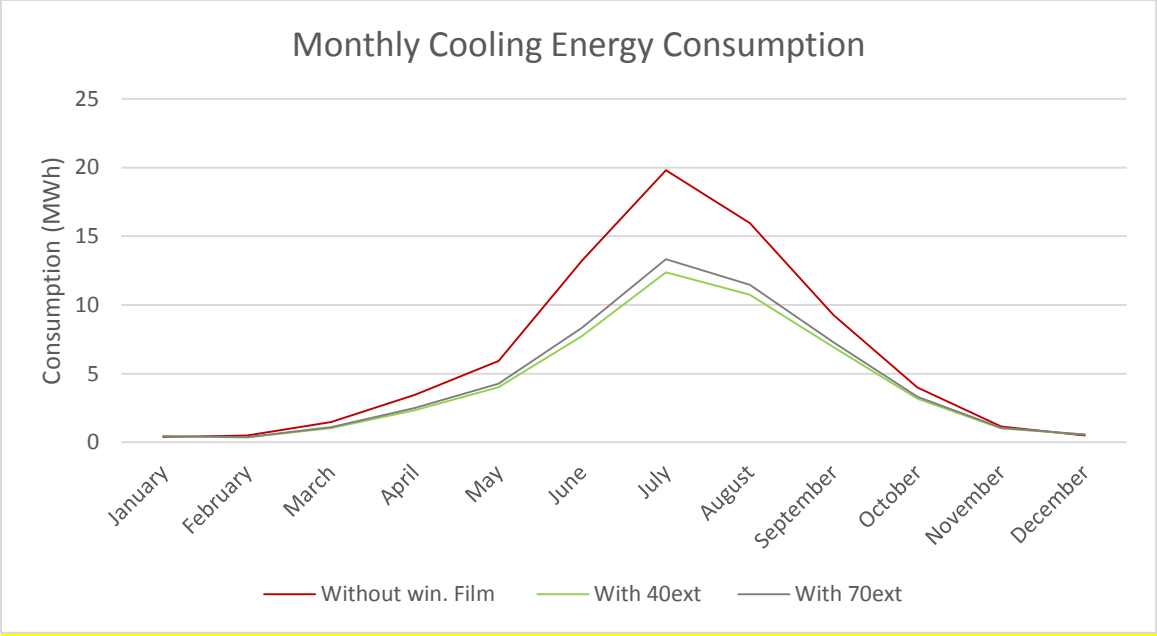

a) Monthly cooling energy consumption

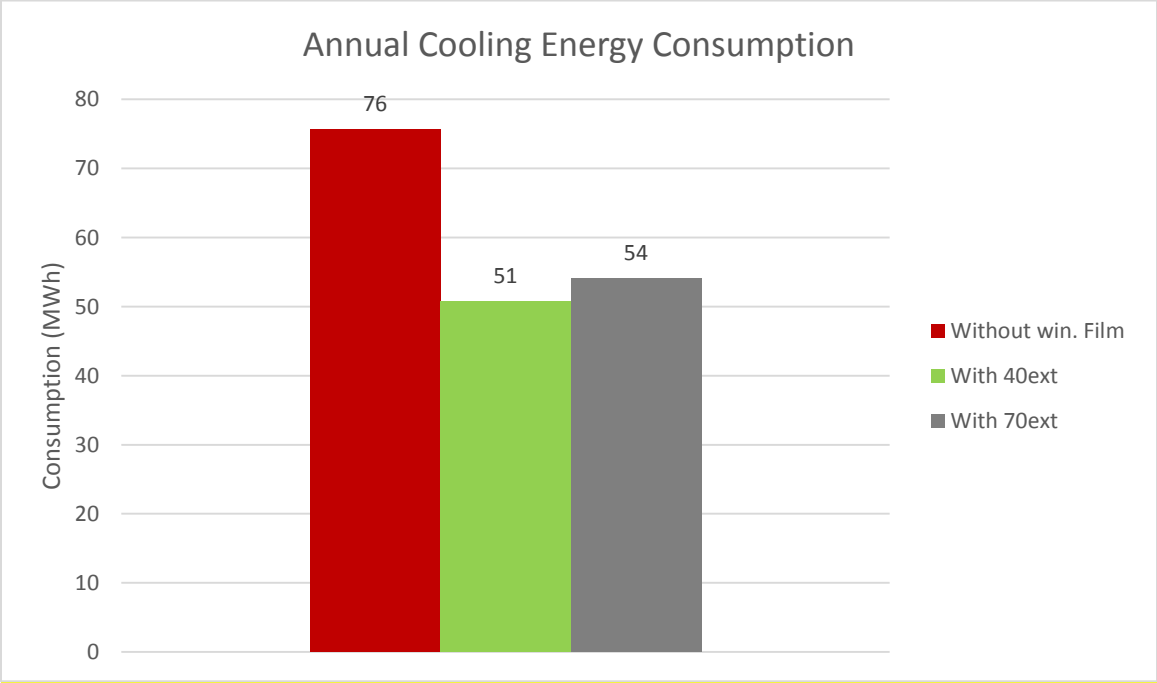

(b) Annual cooling energy consumption

Figure 6.22: Impact of window films on cooling energy consumption (Hilton Reading, Edinburgh simulation)

From Figure 6.22, which shows the effect of the window films on the cooling energy consumption, a similar trend that was observed in the cooling energy consumption for the glazed curtain wall building façade of the Hilton Reading Hotel (London simulation) is exhibited. That is, there is significant savings in cooling energy consumption resulting from the application of the window films. However, the reduction in cooling energy consumption observed for the Hilton Reading Hotel (London simulation) is lower. This is mainly because of the relatively milder summer of Edinburgh and preceding results have demonstrated that the cooling energy consumption is largely associated to the solar heat reduction attributes of the window films which reduce the amount of solar heat gain through the window pane resulting in cooling load reduction during the cooling dominant season.

Therefore, from Figure 6.22(a) showing the monthly energy consumption, it can be noted that the cooling energy savings is largely from April to October with the maximum energy consumption reduction occurring in July around the peak of the summer. The maximum percentage cooling energy reduction of 37% and 33% was observed for window films (3M 40EXT) and (3M 70EXT) respectively. Furthermore, Figure 6.22(b), which illustrates the annual total cooling energy consumption, demonstrates that there is a considerable reduction in the cooling consumption across the year of 33% and 28% for (3M 40EXT) and (3M 70EXT) respectively. The annual reduction in cooling energy consumption is lower than the 35% reduction observed with the Hilton Reading Hotel model and is not substantial enough to result in the reduction of overall energy consumption of the building, due to the adverse increase in heating energy consumption across the year.

Figure 6.22 presents the results of the impact of the window films on the CO₂ emissions of the building.

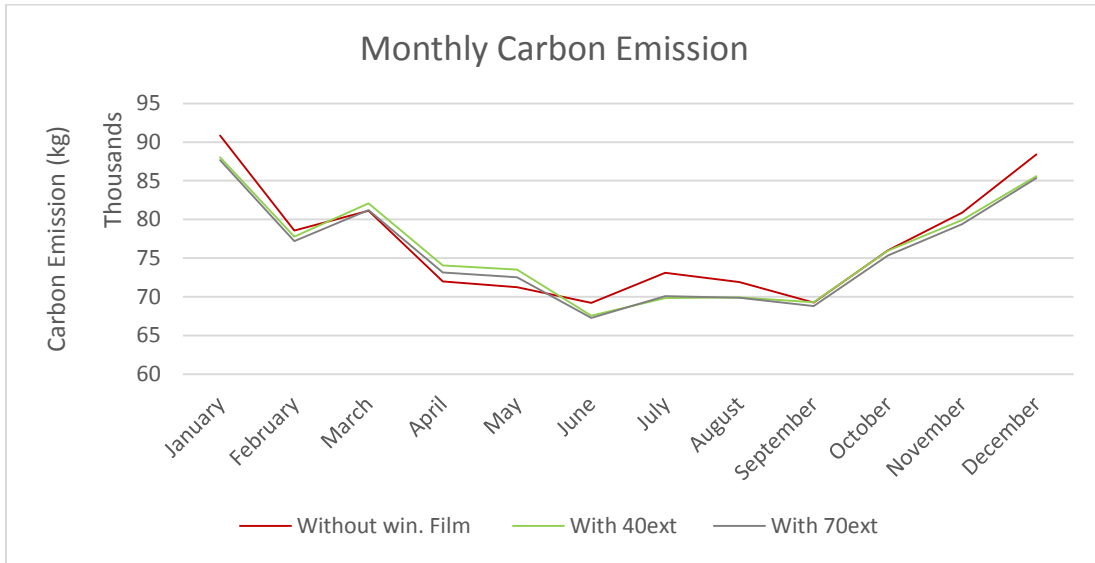

(a) Monthly carbon emission

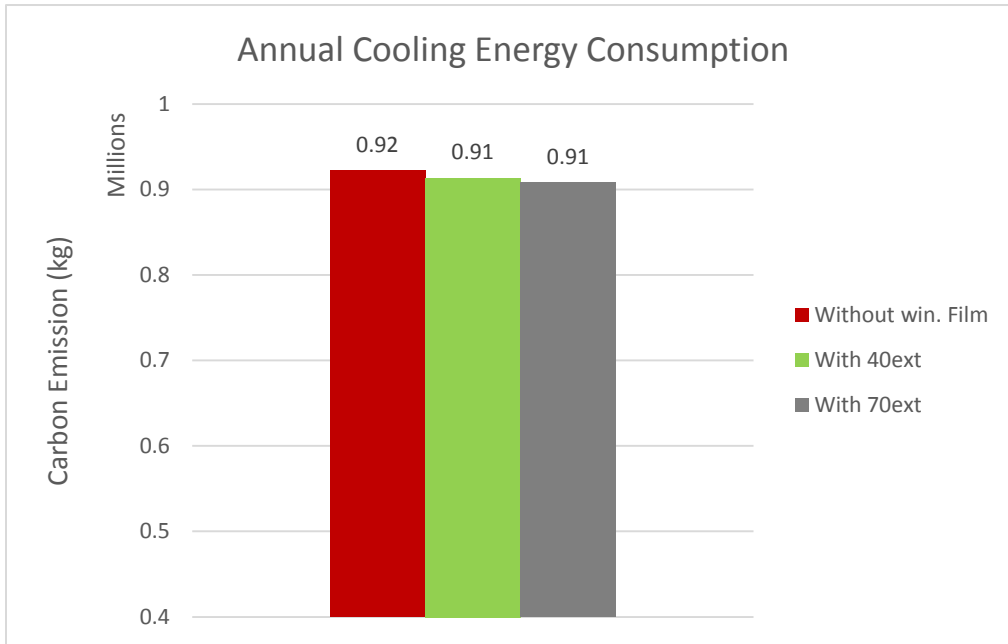

(b) Annual carbon emission

Figure 6.23: Impact of window films on CO₂ emissions (Hilton Reading, Edinburgh simulation)

From Figure 6.23, it can be noted that there is a marginal reduction in the overall CO₂ emissions due to the application of the window films. Since the reduction in the cooling energy consumption resulting from the impact of the window film is mainly during the summer, Figure 6.23(a) shows that the bulk of the CO₂ emission reductions also occur during the cooling dominant period. Moreover, CO₂ emission reduction resulting from the reduction in cooling demand is worth more in terms of kg as this is driven by a reduction in electricity consumption. Hence from Figure 6.23(b), which shows the annual total CO₂ emissions result, it can be observed that there is a marginal percentage reduction in the overall CO₂ emissions across the year. Similar to the results of the Hilton Reading Hotel (London simulation), the figure shows that there is a marginal total annual CO₂ emission reduction of approximately 1.0% and 1.6% observed for window films (3M 40EXT) and (3M 70EXT) respectively, which is just lower than the 2% reduction observed for the Hilton Reading Hotel London simulation results.

Table 6.5: Summary table showing percentage difference between simulation result without window film compared to simulation result incorporating window films on all orientation (Hilton Reading, Edinburgh simulation)

Window Films	Heating Energy Consumption (%)	Cooling Energy Consumption (%)	Total Energy Consumption (%)	Total CO ₂ Emissions (%)
3M 40EXT	-1.8	33	0.4	1.0
3M 70EXT	-1.4	28	1.2	1.6
Note: (– Negative) is percentage increase; (+ Positive) is percentage decrease.				

6.7 Summary and Conclusion

This chapter presents two case studies on the evaluation of the impact of window films on the energy performance of existing UK hotel buildings. The case study hotel buildings have distinct building façades and construction. The feature of the first case study building (Hilton Reading Hotel) is a mainly single-skin glazed curtain wall structure with a relatively high window to wall ratio whereas the second case study building (Hilton London Heathrow Airport Terminal 4 Hotel) is a conventional building with a primarily framed structure, cavity walling and double-glazed windows. Additionally, this chapter also presents an evaluation of the impact of the films on the Hilton Reading hotel glazed curtain wall building with the Edinburgh weather data to assess window films application in relatively colder UK locations. The simulation was conducted using

building energy simulation software (EDSL TAS) and the energy prediction result of the software was validated with actual building consumption data before simulation of the effect of selected window films on the energy consumption and performance of the case study buildings.

The results of the investigation demonstrate that the impact of the selected window films (3M sun control window film; Prestige 70 Exterior and Prestige 40 Exterior) on the overall energy consumption of the case study buildings is not substantial, especially for the conventional frame structure and wall façade of the Hilton Heathrow Airport Terminal 4. Additionally, there is also no energy saving resulting from the application of window films on either the east or west facing windows only. The overall energy savings accruing from the application of the films on all windows, irrespective of their orientation, is approximately 2% and 1.2% for Hilton Reading Hotel (London weather simulation) and Hilton Reading Hotel (Edinburgh weather simulation) respectively; this is mainly attributed to the reduction in cooling energy consumption. Whereas for the Hilton London Heathrow Hotel, the window films resulted in a 0.6% marginal increase in total energy consumption. This is because the window films do not provide enough of a reduction in cooling energy consumption to neutralise the observed increase in winter heating energy consumption.

Although the energy saving from the application of the window films is marginal, an examination of the components of energy consumption, that is, heating and cooling energy consumption, which the window films have a direct impact on, provides further insight into the effect of the window films. This investigation indicates that the window films produce a reduction in cooling energy consumption by up to 35% during the peak of the cooling season and 35% reduction in the annual overall cooling energy consumption across the year for Hilton Reading Hotel. Likewise, for the

Hilton London Heathrow Hotel, the window films provided a reduction in cooling energy consumption by up to 17% during the peak of the cooling season and a similar 17% reduction in the annual overall cooling energy consumption throughout the year. The reduction in cooling energy consumption obtained is due to the reduction in solar heat gain via the window pane. However, some of these savings are slightly negated during the heating period, with the result showing a maximum increase in heating energy consumption by up to 11% during the peak of the heating dominant season. However, the overall increase in annual heating energy consumption for both case study buildings is approximately 2%.

The result of the cost and CO₂ emissions analysis also demonstrates that cost and CO₂ emission savings of up to 2% are achievable with the application of the window films, particularly in the case of the glazed curtain wall building façade of the Hilton Reading Hotel (London Simulation).

However, for the conventional frame structure and wall façade of the Hilton Heathrow Hotel, there is approximately no cost saving accruing from the window film application. Moreover, the marginal percentage increase in CO₂ emission for this building is approximately 0.3%. Additionally, a critical analysis of the results shows that window films window films (3M 40EXT) and (3M 70EXT) window films applied to both clear and tinted windows delivered relatively similar performance. Hence, the choice of window film for this study can be made between the two window films with preference depending on whether the tinted window film is required for privacy and ambience consideration.

Furthermore, the result of the investigation indicates that the application of window films alone, especially in relatively large hotel buildings, cannot significantly reduce the overall energy consumption. However, their other benefits of improving the internal thermal comfort of the

building by reducing solar heat gain and glare make them a desirable retrofit option. Moreover, this investigation shows that window film application in a primarily single-skin glazed curtain wall structure with relatively high window to wall ratio is more beneficial than in a conventional building with a primarily framed structure and cavity walling. Additionally, it can be more beneficial if window films are used along with other energy efficiency measures that can reduce the energy consumption of other components such as domestic hot water and lighting, which make up considerable proportions of overall energy consumption.

Chapter 7: Optimum Size Selection of CHP Retrofitting in Existing UK Hotel Buildings

7.1 Introduction

Energy consumption and efficiency are important energy performance indicators in buildings for several stakeholders (such as energy end-users, researchers and governments) due to the continuous increase in global energy cost, depletion of available conventional energy resources and the adverse impact of global climate change and greenhouse gas emissions (Babaei *et al.*, 2015). Research findings have highlighted the considerable proportion of building energy consumption accounting for around 40% of global energy consumption and its contribution to yearly greenhouse gas emissions, which account for up to 30% of global emissions (UNEP-SBCI, 2009; Fumo, 2014). However, compared to the other main greenhouse gas emitting sectors, the building sector has the biggest potential for substantially reducing emissions with relatively less costly investments, especially since proven technologies that can reduce energy consumption and improve energy efficiency in both new and existing buildings are already commercially available (UNEP-SBCI, 2009).

Therefore, the current global challenge is to ensure that the energy saving potential in the building sector is fully harnessed. In addition, improving energy efficiency in buildings is central to mitigating against increasing greenhouse gas emissions and energy demand, which is projected to rise by 2050. Furthermore, energy efficiency is anticipated to play an important role in relation to sustainable global development since it helps in the reduction of energy consumption and greenhouse gas emissions without compromising societal welfare (Wada *et al.*, 2012). Significant energy savings and reduction in global building emissions can be achieved with extensive

deployment of a variety of best available technologies including: high performance windows, improved levels of thermal insulation, heat pumps, solar heating and cooling, Combined Heat and Power, energy efficient equipment and lighting among others (IEA, 2013b).

The CHP system has been highlighted by numerous studies to be one of the proven and reliable technologies that can improve the efficiency of heat and electricity generation. The extensive adoption of this type of technology is crucial in reducing building emissions in the UK (Nock *et al.*, 2012), especially since recent records indicate that building emissions in the UK have increased in the last two years, with the trend only moderately linked to lower winter temperatures than in 2014 (Committee on Climate Change, 2017). CHP, also known as co-generation or total energy, is the simultaneous utilization of useable heat and power from a single source fuel (such as oil, natural gas, biomass, liquefied gas) at the point of use. This offers a variety of environmental and economic benefits because it is associated with primary energy savings relative to the conventional method (that is, on-site boilers and electricity power stations) (International Energy Agency, 2008; Carbon Trust, 2010; Romero Rodríguez *et al.*, 2016). To derive optimum benefit from a CHP, it is usually designed to run for most of the year and to cater for the heat demand of the building as it is less expensive to transport surplus electricity than surplus heat (IEA, 2008), hence it is only viable for buildings with a high and constant heat demand such as hospitals, hotels, leisure centres and industry retail shops among others. As a rule, CHP is economical for buildings with at least 4,500 hours per annum of high and constant heat demand (Carbon Trust, 2010) but it can also be employed in buildings with a lower heat demand that have high electricity and cooling demand (Carbon Trust, 2010; Nock *et al.*, 2012). Although CHP can take various forms and incorporate a variety of technologies, it is, however, founded upon an efficient and integrated system that

combines electricity generation and a heat recovery system, consequently enabling CHPs to convert between 75-80% of the input fuel into useful energy, with the most modern plants offering over 90% efficiency (IEA, 2008). Figure 7.1 shows the typical energy savings of a CHP system relative to traditional energy sources of heat and power generation in the UK:

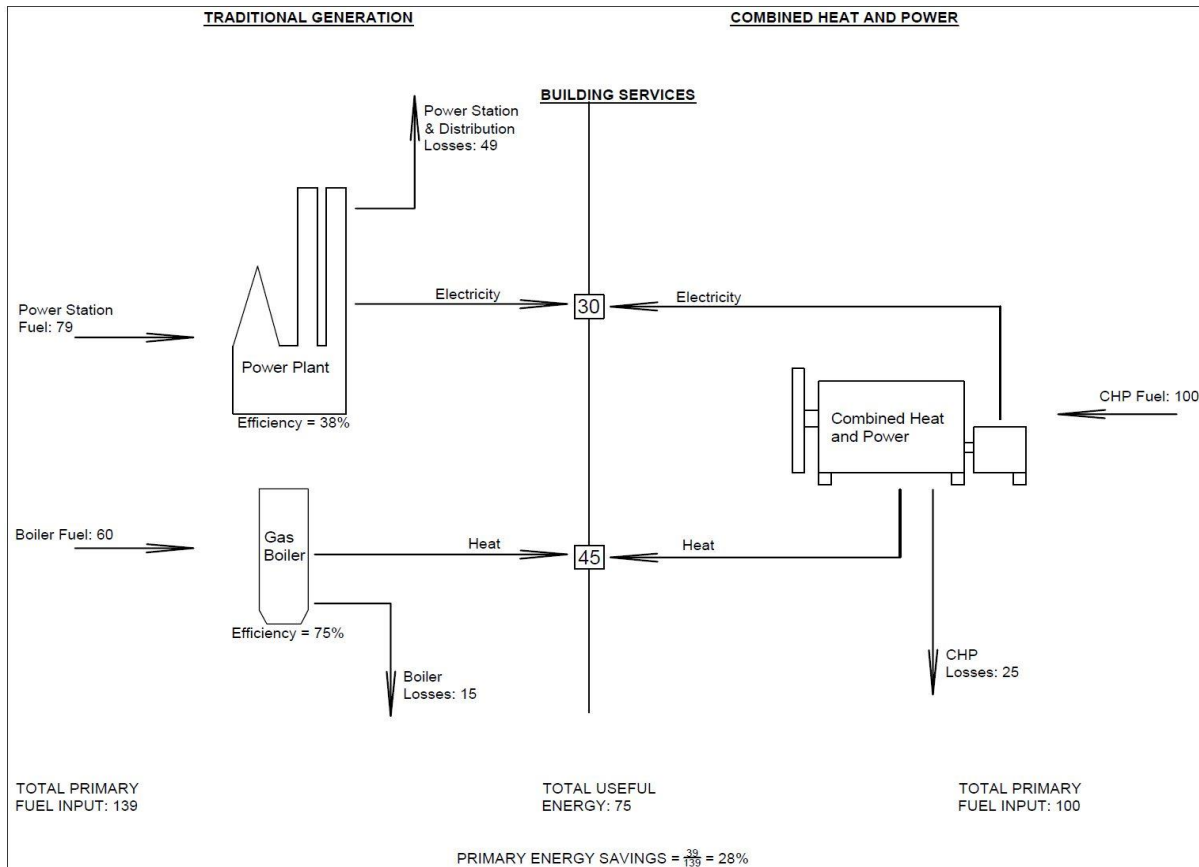

Figure 7.1 Typical energy savings of a CHP system relative to traditional energy sources of heat and power generation in the UK (Carbon Trust, 2010).

Commercial buildings like hotels have a significant demand for hot water, space heating and cooling load consistently throughout the year, which substantially enhances the competitiveness of cogeneration application (IEA, 2013b). However, there are some barriers against the wide

spread adoption of CHP in buildings, the most critical of which is the significant upfront cost in plant installation and optimum scaling concerns (Romero Rodríguez *et al.*, 2016). The benefits of CHP range from its associated lower utility costs, improved environmental performance and energy supply security. Moreover, the UK Government CHP Quality Assurance programme appraises and certifies CHP schemes, which makes them eligible for various benefits and incentives, including Renewable Obligation Certificates, Renewable Heat Incentive, a Climate Change Levy (in relation to electricity directly supplied), Enhanced Capital Allowances, Carbon Price Floor (heat) relief and preferential Business Rates (Department for Business, Energy & Industrial Strategy, 2017a). Furthermore, the programme evaluates CHP schemes based on their energy efficiency and environmental performance, thus ensuring that the accompanying fiscal benefits are in line with environmental performance.

The focus of this case study was to estimate the maximum CHP size to be retrofitted in an existing UK hotel building with the use of dynamic simulation software. The maximum CHP capacity is sized based on the base heating demand of the hotel with a priority to meet the domestic hot water demand, which is considerable and consistent throughout the year. Subsequently, the size is reduced to 70% of the maximum CHP capacity at a rate of 10%. Critical analysis of the economic and environmental benefit of the CHP over these size range enables the selection of the optimum CHP size to be retrofitted. The Hilton London Gatwick Airport Hotel building was used as a case study for this evaluation.

Usually, in theory and practice, CHP systems in new and existing buildings are sized to match the capacity of the CHP to the base heat load of the building, to derive the most benefit (Action Energy, 2004). However, this work makes a contribution to existing knowledge as it presents a practical

approach of assessing the optimum CHP size by critical analysis of a range of sizes. especially for large hotel buildings that tend to have substantially more heating demand compared to their electricity requirement. Moreover, this work presents an approach of retrofit CHP sizing which is relatively more accurate as it involves dynamic whole building simulation, therefore the CHP is not sized based on just the annual heat demand of the building. Rather, the CHP is sized on the results of peak heating design day from the thermal analysis simulation.

7.2 Building Description

The description of the case study building (Hilton London Gatwick Airport Hotel) used for this evaluation is provided in preceding section 4.2.3.

7.3 Case Study Method

The aim of this study was to evaluate the maximum and subsequently the optimum CHP size to be retrofitted in a UK case study hotel building, located in the southeast of the United Kingdom. The evaluation was conducted with the aid of an approved dynamic simulation software. The general methodology and core processes that were used to develop the holistic model on the dynamic simulation software TAS were presented in preceding sections 3.7 -3.10. However, some information peculiar to this case study is presented in this section.

The procedure that was used to achieve the articulated aim using the case study building can be categorised into two distinct stages. The initial stage involved evaluating the energy performance of the building by creating a holistic model (base model) which is representative of the building fabric, systems and thermal behaviour of the actual building. Energy consumption, which is a central indicator of estimated energy performance was validated and verified by comparing against the actual building consumption data. The consumption data were obtained from onsite gas and

electric meter readings. The case study building was inspected to facilitate the verification of available data such as building fabric data (e.g., walls and windows), occupancy information to ensure that simulation assumptions were representative, building usage to ensure that zone grouping is as indicated on the architectural plan and the HVAC systems characteristics. The second phase entailed the incorporation of the CHP system into the model to evaluate the maximum CHP size. Subsequently, the size was reduced at a rate of 10% to inform the selection of the optimum size of CHP from the succeeding critical analysis.

7.3.1 3D modelling

The data used to create the 3D model for the whole building simulation was collected from the CAD drawing file of the hotel building. As advanced in section 3.7, they provided necessary information on the geometry of the building, layout and functional use of the different zones of the building. Figure 4.3 in preceding section 4.2.3 shows the typical AutoCAD Architectural floor plans used in the 3D modelling process of the building.

7.3.2 Simulation process

The dynamic thermal simulation of the building was executed by the TAS TBD component of the software. Careful and judicious selection of modelling parameters was critical at this stage to obtain the appropriate results. The necessary simulation parameters such as calendar, weather data, building elements, zones, internal condition and aperture types were populated to perform the thermal performance of the building. Figure 3.3 in section 3.7 illustrates the thermal simulation process employed. Tables 4.8 to 4.10 in section 4.3.2 present the modelling parameters and assumptions base the case study building's characteristics for Hilton London Gatwick Airport hotel. Additionally, Figure 7.2 illustrates a summary of the case study method.

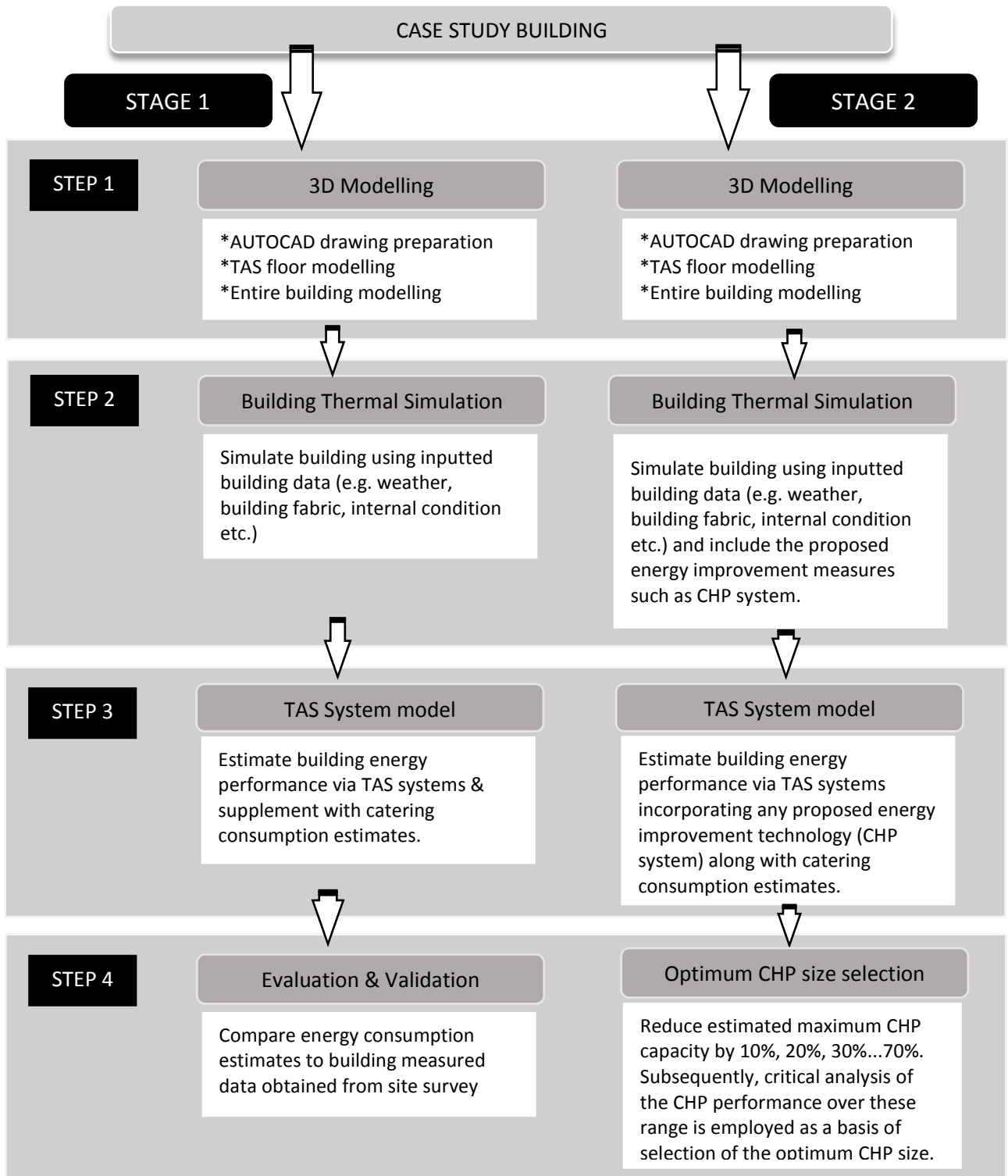

Figure 7.2: Summary of case study method

7.4 Results and Discussion of Results

7.4.1 Base model (without CHP)

The results for and discussion of the case study hotel building are presented in this section. Preceding section 4.4.2 of this thesis presented the results and discussion of results for the first stage of this study which entails estimation and validation of the case study building the energy consumption (that is, the base model without CHP).

Figure 7.3 shows the breakdown of the monthly energy demand, which includes space heating and DHW. It also accentuates the suitability of CHP for the case study building. It can be noted from the figure that the building has high and constant heat demand throughout the year, especially DHW demand which is up to 64% of the total energy demand even in the peak of the summer. This high and constant DHW demand, which is consistent with hotel buildings, allows selection of the maximum size of CHP to be underpinned by the base line heat load with priority to DHW.

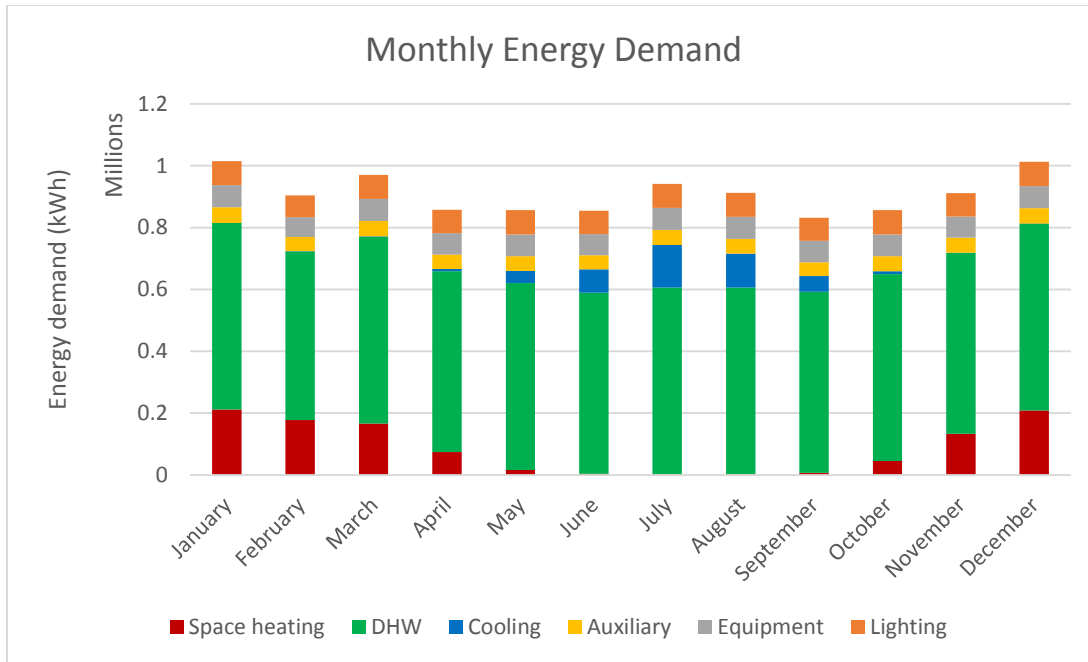
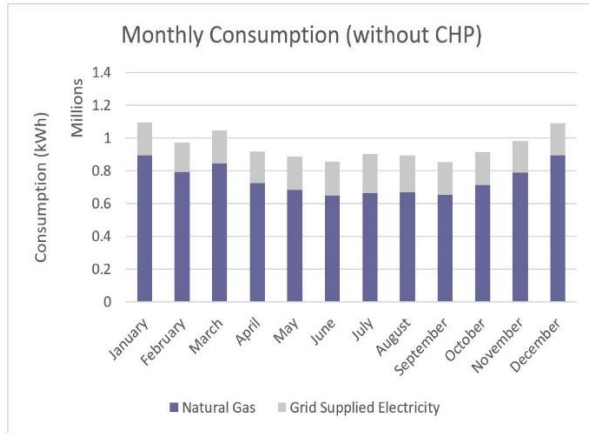

Figure 7.3: showing the breakdown of building energy demand

7.4.2 Model with maximum capacity of CHP

The subsequent stage of the analysis entailed the simulation of the case study building with CHP to determine the maximum size of CHP system that is beneficial based on the base thermal energy demand of the building. The capacity of the CHP estimated from this maximum beneficial sizing simulation is 750kWe with a heat to power ratio of 1.2. Figures 7.4 to 7.7 present the results of the analysis comparing the energy performance of the building without CHP against the building model with the maximum capacity of CHP:



(a) Monthly total energy consumption without CHP

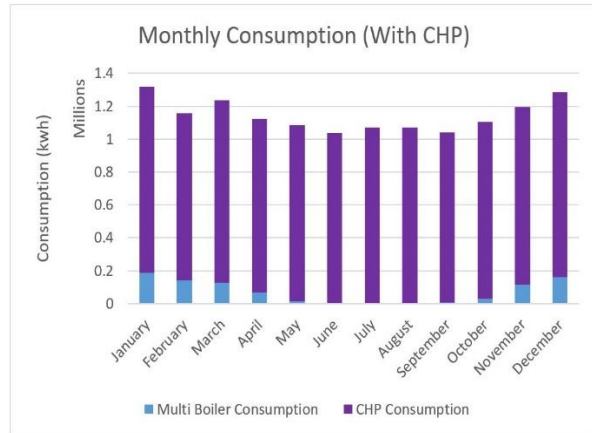

(b) Monthly total energy consumption with CHP

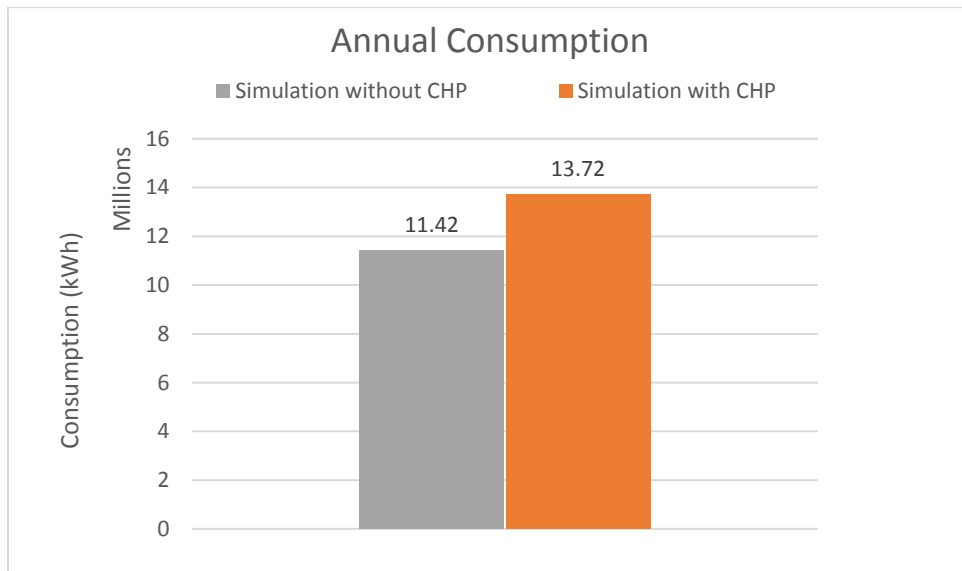

(c) Annual total energy consumption without CHP vs. with CHP

Figure 7.4: Total energy consumption result (without CHP vs. with CHP)

Figure 7.4 shows the result of the total end use energy consumption of the building without CHP compared to that with a CHP installed. It can be observed from Figures 7.4 (a) and (b), that the incorporation of the CHP resulted in the change of the fuel/energy mix of the building from natural

gas and grid supplied electricity to primarily natural gas. This is because the CHP produces sufficient electricity and a substantial proportion of heat to serve the building while the shortfall in the heat requirement is met by the boilers. In most cases, this results in an increase in the end use energy consumption of the building as more natural gas is required to run the CHP. However, the associated improved energy efficiency usually offsets the increased onsite fuel consumption (Action Energy, 2004). From Figure 7.4(c), an increase in annual total end use energy consumption can be observed, with the CHP model indicating a 20% increase compared to the building model without CHP:

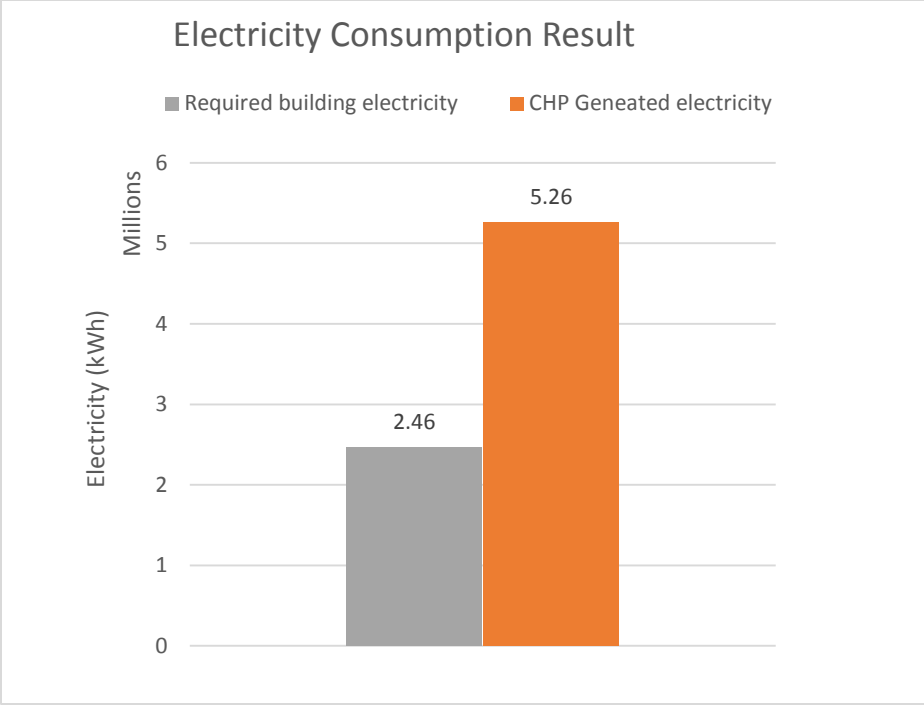

(a) Building electricity consumption vs. Generated CHP electricity

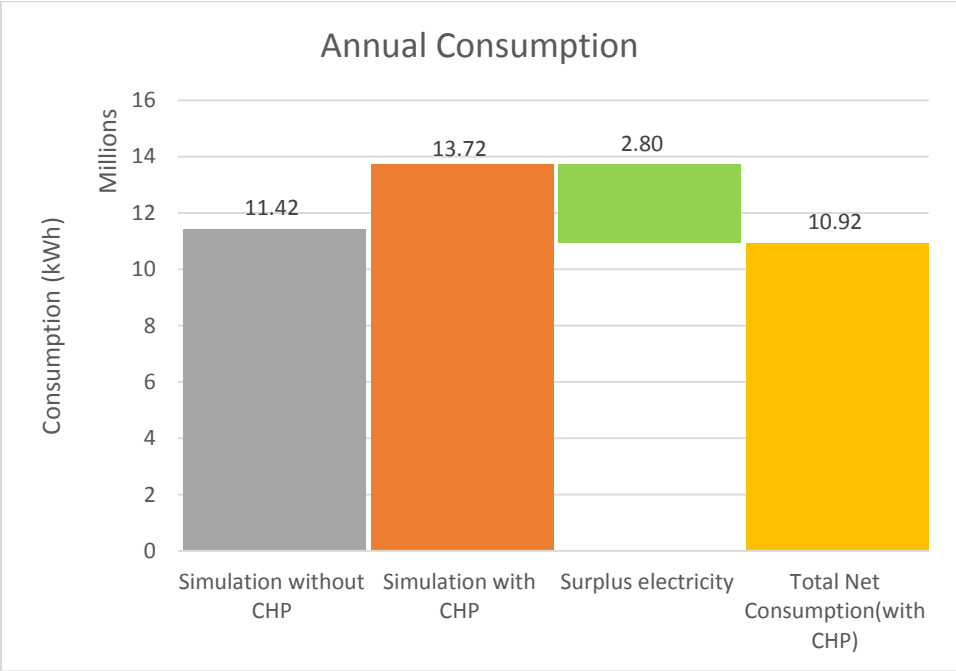

(b) Annual total energy consumption

Figure 7.5: Electricity generation results and total energy consumption

Figure 7.5 presents the results of CHP electricity generation and its relation to the end use energy consumption. From Figure 7.5(a), it can be seen that the CHP generates up to **double** (2,800,317kWh) more electricity than the electricity requirement of the building. The surplus electricity can be exported back to the grid, contributing to the reduction in total energy cost. In Figure 7.5(b), as highlighted earlier, it can be seen that the end use energy consumption is higher due to the increased consumption of natural gas. However, the natural gas produces both heat and electricity to be used by the building, therefore, the surplus electricity which is a positive to the site can be deducted from the total end use energy consumption of the CHP model. This energy balance gives an estimation of the total net energy consumption (with CHP) demonstrated in Figure 7.5(b) which is even marginally lower than the total energy consumption of the building without CHP.

Since the benefits of the CHP system are attributed to its energy efficiency, it is insightful to investigate the impact of the CHP on the carbon emissions and energy utility cost of the building, especially as the conversion factor and price rate used for estimating energy costs and carbon emissions resulting from natural gas and grid electricity are different. The CO₂ conversion factors of 0.184 for natural gas and 0.281 for grid supplied electricity used for this analysis were obtained from the UK Government GHG Conversion Factors for company reporting spread sheet 2018 (BEIS, 2018b). The tariff rate of £0.108 per kWh for grid supplied electricity and £0.0273 per kWh for natural gas used in the cost analysis was obtained from the case study building energy supply data. As recommended by the Office of Gas and Electricity Market (OFGEM), the feed-in tariff rate of £0.0503 was used for the CHP surplus electricity (OFGEM, 2017). The results of the impact of CHP on energy costs and carbon emissions are presented in Figure 7.6:

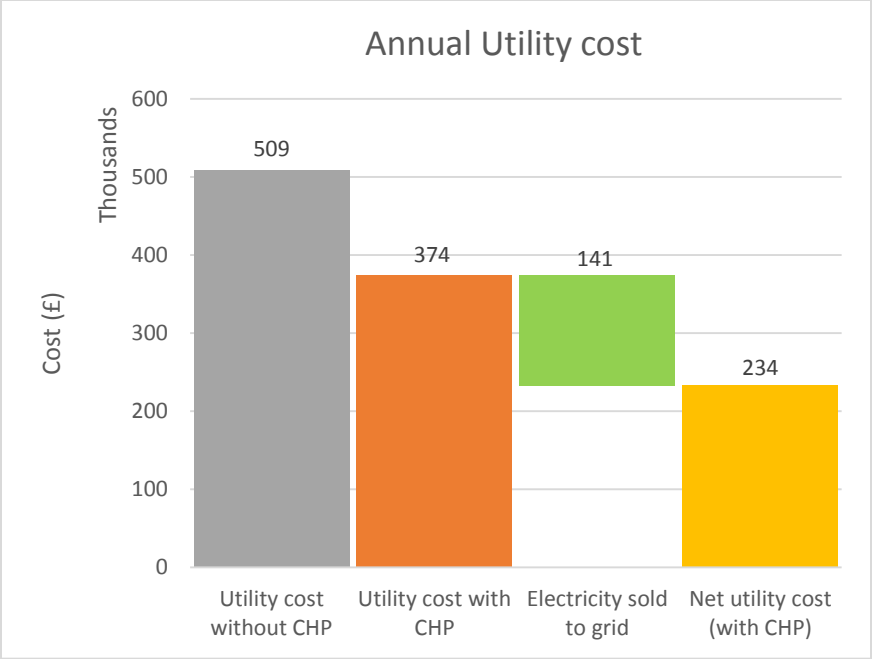

a) Annual utility cost comparison (without CHP vs. with CHP)

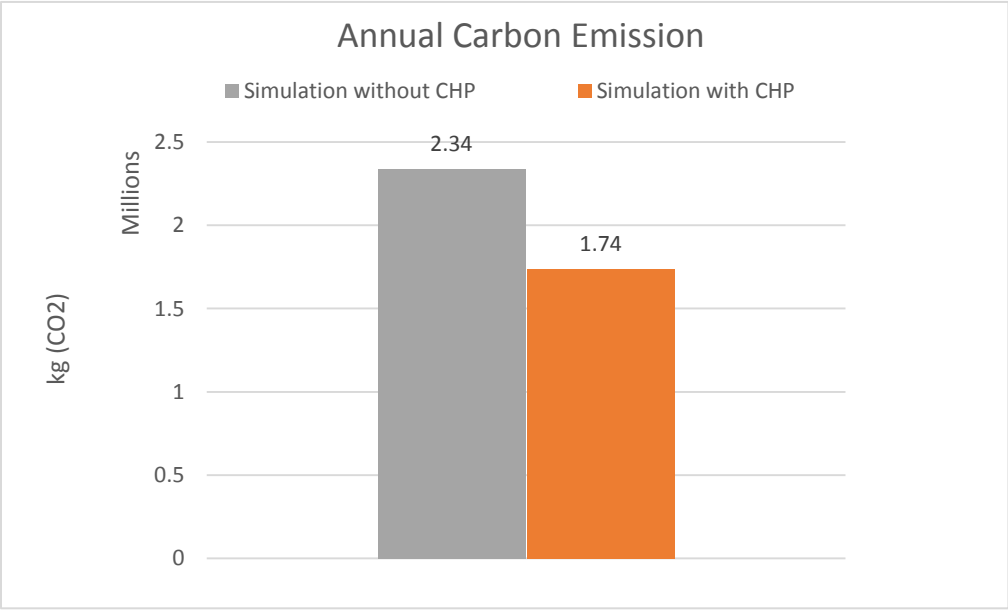

(b) Annual Carbon emission (without CHP vs. with CHP)

Figure 7.6: Cost and carbon emission result (without CHP vs. with CHP)

It can be observed from Figure 7.6(a), showing the annual utility cost result, that the utility cost of the model with CHP was 26% lower than that without a CHP even though the end use energy consumption of the CHP model was considerably higher than that without a CHP. The reduction in cost was due to the change of the fuel source of the CHP model to gas only compared to the conventional gas and electricity energy source in the building without CHP, consequently taking advantage of the cheaper price of natural gas. Additionally, the CHP model produced more electricity than that required by the building, which can be sold back to the grid at a flat or negotiated rate similar to grid supplied electricity. Accounting for the sale of the surplus electricity resulted in up to 54% reduction in utility cost (i.e. the net utility cost). From Figure 7.6(b), illustrating the annual CO₂ emissions result, it can be noted that the CHP model provided a 26% reduction in CO₂ emissions compared to the model without CHP. The CO₂ emissions reduction was mainly due to the energy efficiency of the CHP system and its associated reduction in primary energy consumption.

7.4.3 Model with CHP; 307kWe

Owing to the high proportion of surplus electricity produced by the CHP sized based on the thermal requirement of the building, it allows the hotel to explore reducing the size of the CHP system to match more closely with the electrical demand of the building. This can lower the capital cost of the installation and reduce complexities associated with exporting electricity whilst still providing considerable cost and environmental benefits. Moreover, it is generally more important to ensure that CHP is not oversized rather than undersized, in contrast to most building services plants and installations (CIBSE, 2013b). Therefore, the hotel management and the CHP provider have selected a 307kWe capacity CHP; the results of the simulation investigating the benefits of this

system are presented in this section along with an approach that can be employed to aid in the selection of the optimum CHP size based on an evaluation of the key benefits of the CHP size variation analysis. Figures 7.7 to 7.9 present the results of the analysis comparing the energy performance of the building without CHP against the building model with a 307kWe CHP:

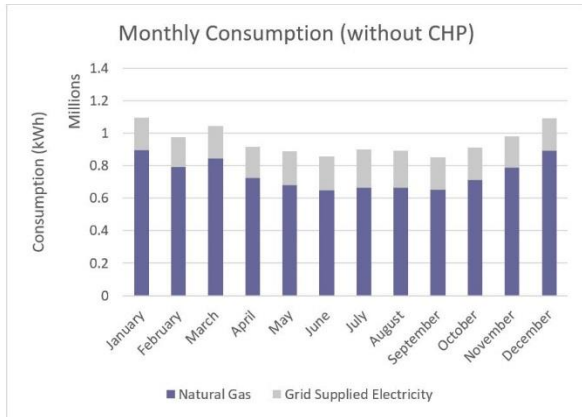

(a) Monthly total energy consumption without CHP

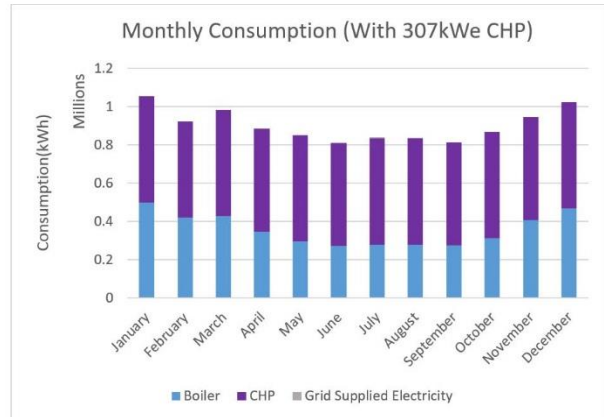

(b) Monthly total energy consumption with CHP

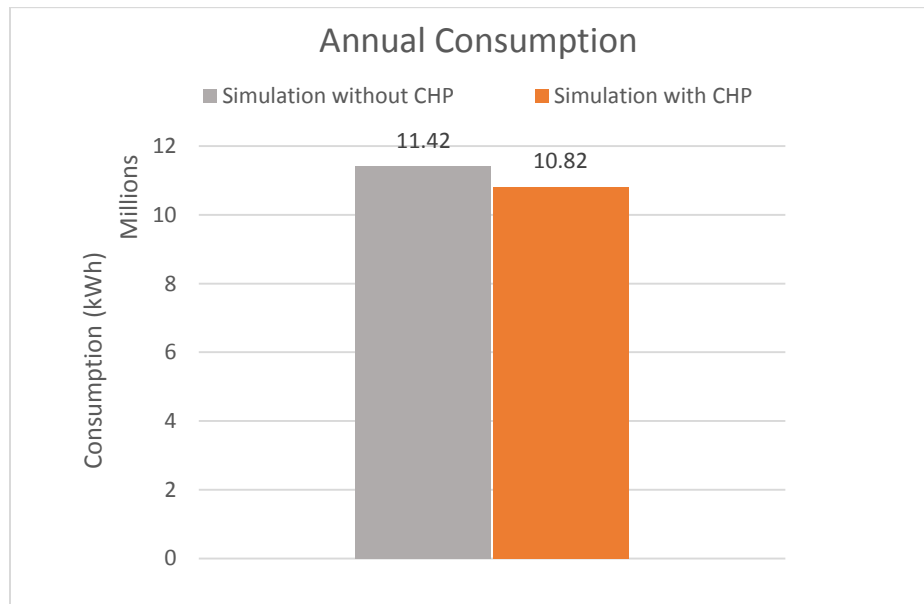

(c) Annual total energy consumption without CHP vs. with 307kWe CHP

Figure 7.7: Total energy consumption result (without CHP vs. with 307kWe CHP)

Similar to the model with a maximum sized CHP, it can be observed from Figures 7.7 (a) and (b) that the simulation with the 307kWe CHP resulted in a change in the fuel/energy mix of the building from natural gas and grid supplied electricity to mainly natural gas. This is because the CHP produces sufficient electricity to satisfy majority of the electricity demand of the building, except during the peak of the summer when a small amount of grid supplied electricity is required. Moreover, the CHP produces substantial proportion of heat to serve the building while the supplementary heat requirement is met by the boilers. In contrast to the increased energy consumption observed with the maximum size CHP, as shown in Figure 7.7(c), the end use energy consumption of the model with a 307kWe CHP is 5% lower than the base model without CHP. This is due to the considerable reduction in size of the installed CHP from the maximum size of 750kWe to 307kWe.

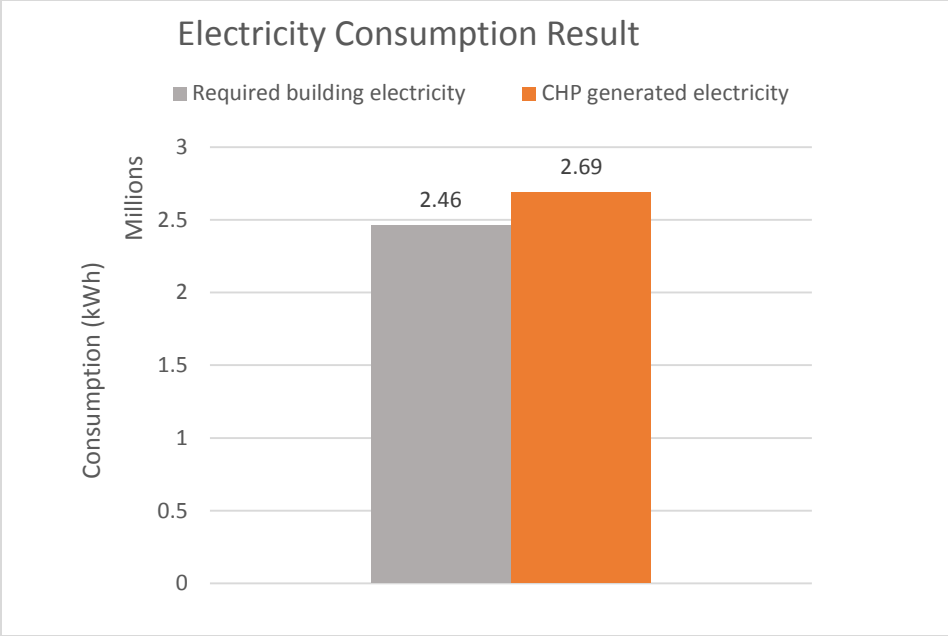

(a) Building electricity consumption vs. Generated CHP electricity

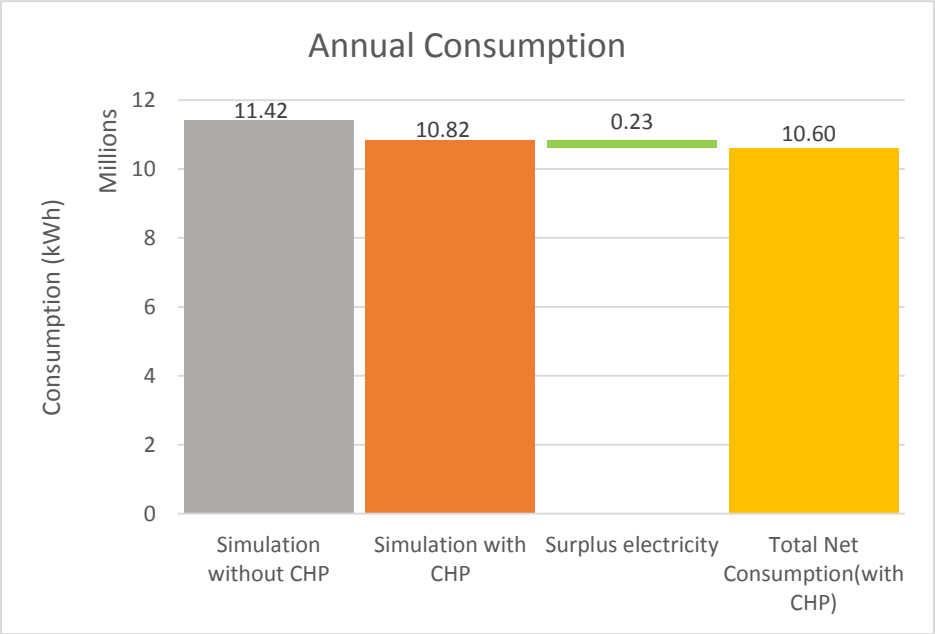

(b) Annual total energy consumption

Figure 7.8: Electricity generation results and total energy consumption (307kWe CHP)

The results of electricity generation and their relation to the end use energy consumption for the 307kWe CHP model are presented in Figure 7.8. It can be noted from Figure 7.8(a), that despite the reduction in CHP size by more than 50% from 750kWe, the CHP model generates sufficient electricity to satisfy the electricity requirement of the building. Moreover, surplus electricity of up to 9% is generated and can be sold back to the grid. From Figure 7.8(b), an energy balance can be deduced by subtracting the surplus electricity, which is an added benefit to the site from the total end use energy consumption. This gives an estimation of the total net energy consumption, which is up to 7% lower than the total end use energy consumption of the building without CHP. To further evaluate the impact of the selected 307kWe CHP, the results of the impact of the CHP on energy costs and carbon emissions are presented in Figure 7.9. The installation of the selected 307kWe CHP is to be financed by an equipment supply finance (off-balance sheet approach). The Carbon Trust (2010) defines this approach as a common option used to finance small packaged CHP systems, which involves making a commercial arrangement for the energy to be provided at prices that incorporate agreed discounts on the open market price. That is, the hotel pays for the natural gas and buys the CHP generated electricity at the agreed rate. The agreed rate with the equipment supplier for the CHP generated electricity for this case study was £0.028 per kWh of electricity. This value was used to estimate the cost savings associated with the equipment supply arrangement.

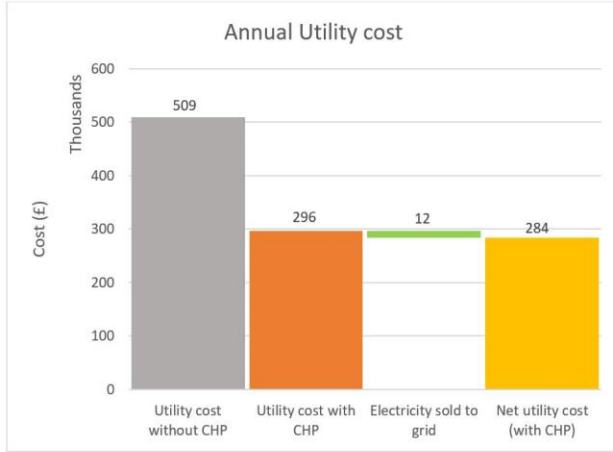

(a) Annual utility cost comparison (without CHP vs. with CHP)

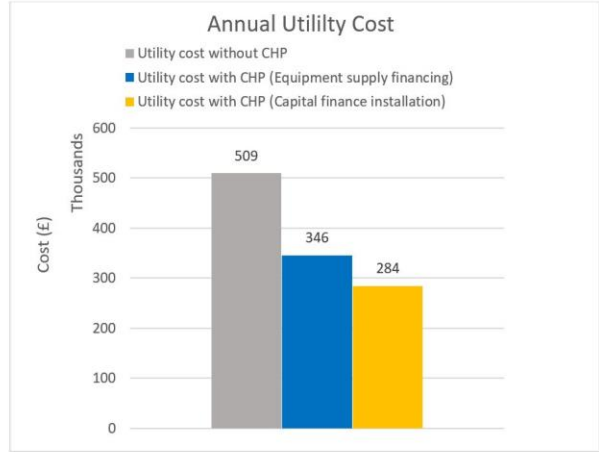

(b) Annual utility cost comparison based on installation financing approach

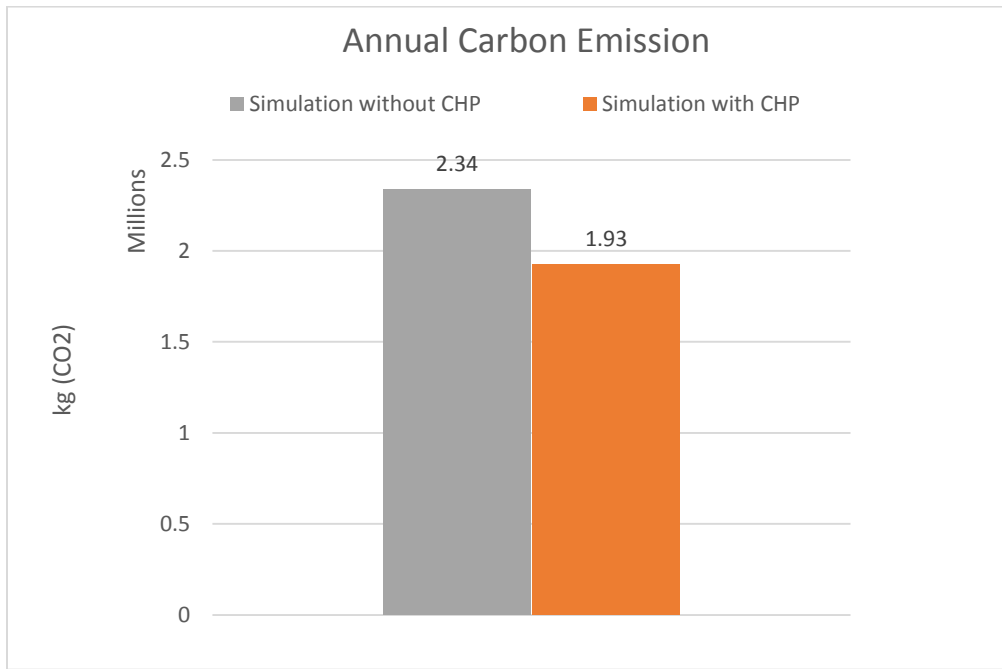

(c) Annual carbon emission (without CHP vs. with CHP)

Figure 7.9: Cost and carbon emission result (without CHP vs. with 307kWe CHP)

It can be observed from Figure 7.9(a) showing the result of the annual utility cost, that the utility cost of the model with the 307Kwe CHP was approximately 42% lower than that without CHP.

This cost saving is even more than the initial 26% saving recorded with the maximally sized CHP model. However, the maximally sized CHP model generate more surplus electricity, which makes its net saving to be substantially more than that of the 307kWe CHP model. It can also be noted from the figure that accounting for the sale of the relatively smaller surplus electricity produced from the 307kWe provides a net utility cost saving of up to 44%. Figure 7.9(b) presents a comparison of utility cost depending on the installation financing option (capital installation or equipment supply finance). It can be observed from the figure that the utility cost with the CHP installed by capital financing and the CHP installed by equipment provide 44% and 32% reduction in utility cost respectively. The capital financing installation approach provides up to 12% more savings in utility cost compared to the equipment supply financing. However, it is not the selected financing approach due to the considerable technical and financial risk associated with this approach. From Figure 7.9(c), illustrating the annual CO₂ emissions result, the 307kWe CHP model provides a 21% reduction in CO₂ emissions compared to the building model without CHP. Moreover, compared to the model with the maximum sized CHP, the CO₂ emission savings is only 5% lower, despite the more than 50% reduction in CHP size from 750kWe to 307kWe. This is because the 705kWe CHP requires considerably more natural gas to produce heat and off grid electricity, in addition, the CO₂ conversion factor for grid supplied electricity has improved in recent times due to the increased proportion of renewable energy and the phasing out of coal power plants.

Figure 7.10 presents the result of the effect of projected UK Grid decarbonisation for the CHP installation based on the BEIS projections (BEIS, 2018a) which shows that parity between electricity emissions and natural gas factors is being attained around 2020 and could be surpassed

afterwards. Table 7.1 illustrates the UK grid electricity emissions factor projections for the next ten years (BEIS 2018a) used for this analysis.

Table 7.1: UK electricity emissions factor projections

Year	EEP 2017 (kgCO₂e/kWh)
2019	0.1947
2020	0.1809
2021	0.1709
2022	0.1478
2023	0.1443
2024	0.1501
2025	0.1408
2026	0.1142
2027	0.1194
2028	0.1084

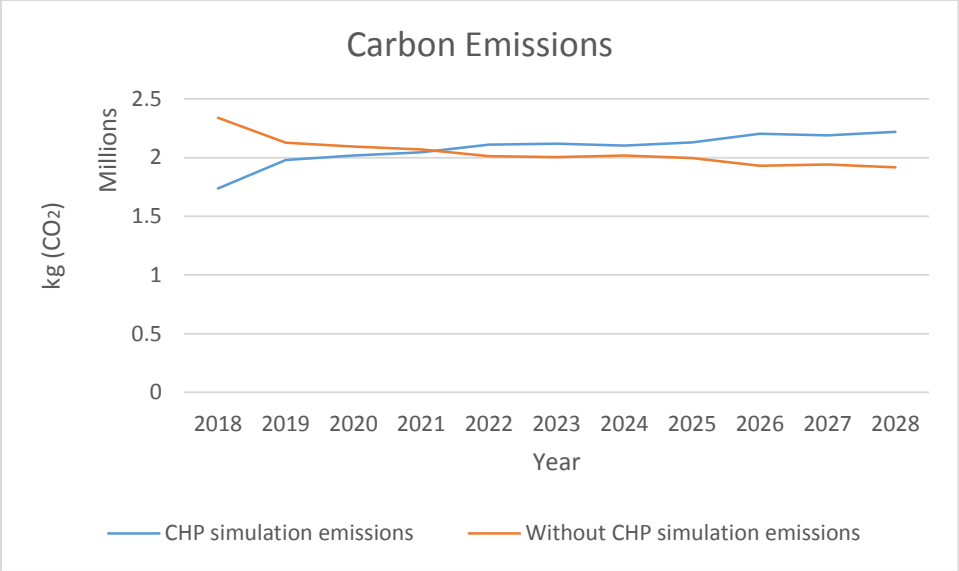

(a) CHP simulation carbon emission vs. Without CHP simulation emissions (Maximum capacity CHP model; sized based on thermal load)

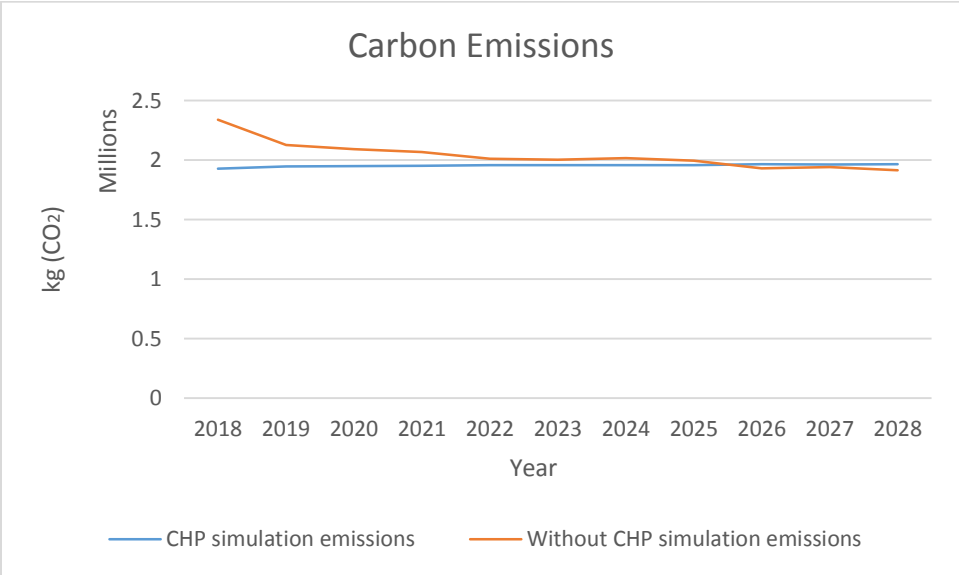

(b) CHP simulation carbon emission vs. Without CHP simulation emissions (307kWe CHP model; sized to avoid electricity export)

Figure 7.10: Impact of UK Grid decarbonisation on the carbon emissions for the CHP installation

Generally, it can be observed from Figure 7.10 that the continuous and projected improvement of the UK grid due to the increase in renewables electricity generation has resulted in the reduction

of the impact of the CHP installation on carbon emissions compared to the building model without a CHP, consequently making the environmental benefits of the natural gas powered CHP less pronounced for the future grid projections. Figure 7.10(a) demonstrates that the CO₂ emissions of the simulation model with maximum capacity CHP which delivers substantial surplus export electricity attains parity with the simulation model without CHP around 2021, and even results in increased CO₂ emissions beyond 2021. This is mainly because the considerable grid displaced, and export electricity generated no longer provide the environmental advantage to the maximum capacity CHP in the future when compared to the potential cleaner UK future grid emission projections. Additionally, Figure 7.10(b) indicate that the CO₂ emissions of the simulation model with the 307kWe CHP, sized to avoid electricity export becomes less obvious from around 2022 relative to the simulation model without CHP and attains parity around 2026 due to projected future grid decarbonisation.

Table 7.2 presents the percentage difference between key simulation results without CHP compared to simulation results incorporating CHP:

Table 7.2: Summary table showing percentage difference between key simulation results without CHP compared to simulation results incorporating CHP

CHP model size (kWe)	Surplus generated electricity (%)	Energy consumption (%)	Energy Utility cost (%)	CO ₂ emissions (%)
750 (Maximum sized CHP; sized on thermal load)	+53	+20	-54	-26
307 (Selected CHP size; sized to avoid export)	+9	-5	-42	-21

Note (+Negative) is a percentage increase (- Positive) is percentage decrease

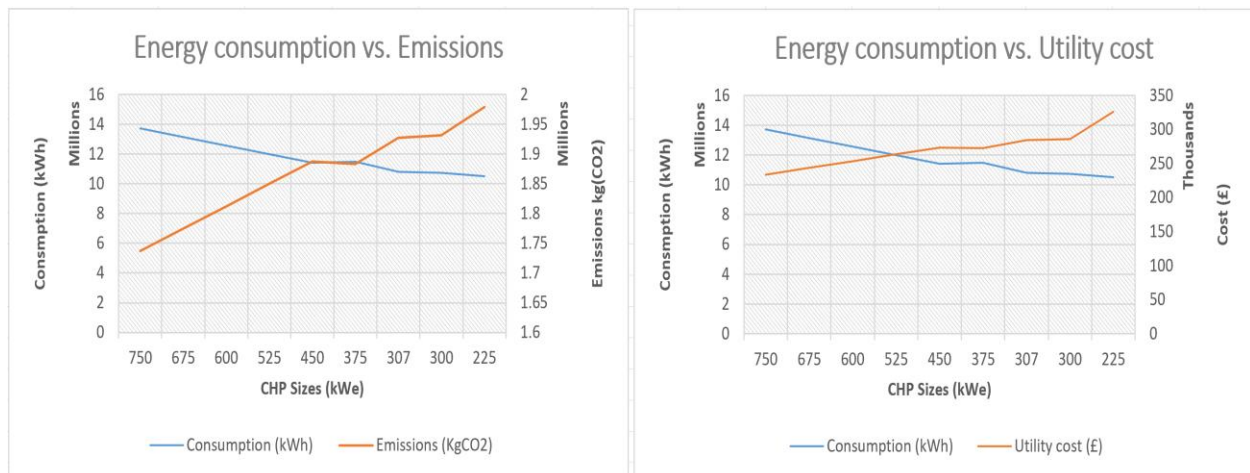

(a) End use energy consumption vs. CO₂ emissions

(b) End use energy consumption vs. Utility cost

Figure 7.11: Showing the relationship between key energy performance parameters and variation in CHP sizes.

Figure 7.11 presents the relationship between the main performance parameters (end use energy consumption, energy cost savings and CO₂ emissions) and their variation with CHP sizes. The end

use energy consumption generally increases with the installation of CHP and exhibits an inversely proportional relationship with the key CHP associated benefits (energy cost saving and CO₂ emission reduction). The increase is primarily due to the change of energy source fuel mix of the building. A plot of the energy consumption and CO₂ emissions or energy consumption and utility cost with the variation of CHP sizes can provide an indication of the optimum CHP size to be selected based on the equilibrium point of the variables. From Figure 7.11(a), it can be observed that an equilibrium between energy consumption and CO₂ emission is reached at a CHP size of 460kWe. From Figure 7.11(b), it can be observed that an equilibrium between energy consumption and utility cost is reached at a CHP size of 525kWe. Furthermore, from the equilibrium points observed in Figure 7.11, the optimum CHP size ranges from 525kWe to 460kWe, which is 30% to 39% smaller than the maximum CHP size of 750kWe. However, selecting the optimum size of 460kWe, which is associated with CO₂ emissions, is better due to its environmental benefits (reduction in primary energy consumption and GHG emissions).

According to CIBSE (2013b), there is no one straightforward way to size a CHP, however, there are relatively simpler sizing approach compared to using DSM. For instance, some common guidance recommends sizing only to satisfy the lowest occurring demand (either cooling or heating) as this ensures the longest operating hours, however, this does not necessarily provide the best economically beneficial approach and limits the environmental benefits (CIBSE 2013b). Therefore, dynamic simulation modelling to size CHP system which computes building energy (heat and electricity) demand profile based on hourly simulation across the year gives the most accurate sizing (CIBSE 2013b), particularly for new buildings and in existing sites in the absence of actual metered demand data. That is, DSM sizing is not based on monthly or annual demand

profile but hourly heating design day result of the thermal simulation. Moreover, dynamic simulation provides the advantage of having a holistic model that enables the evaluation of the impact of other components which are usually done with CHP retrofitting, for example, changing to a more efficient boiler, change of zone usage such as addition of leisure facilities (which can increase DHW demand) amongst others.

7.5 Summary and Conclusion

This work presents a case study to evaluate the selection of optimum CHP size and the impact of CHP on the energy performance of an existing UK hotel. The simulation was conducted using a whole building energy simulation software (EDSL TAS); the energy estimation results of the software were validated with the actual building consumption data prior to the simulation of the impact of the retrofitted CHP and CHP size variation analysis.

The results of the case study demonstrated that retrofit installation of CHP in the hotel, which has consistent and considerable heat demand, improves the overall energy performance of the building. The modelling of the maximum CHP capacity was built based on the thermal energy requirement of the building to avoid heat dumping, and the maximum CHP size of 750kWe was obtained. The energy performance results of the maximum sized CHP relative to the base model indicated that the end use energy consumption increased by 20%. However, the CHP generated 50% more electricity than the building's requirement, which can be exported to the grid. Moreover, the utility cost was reduced by 26% compared to the model without a CHP, with a further reduction in utility cost of up to 54% resulting from the sale of the surplus electricity. Additionally, the maximum sized CHP provides a 26% reduction in CO₂ emissions, highlighting its environmental benefit and associated reduction in primary energy consumption. However, the result of the analysis of the

effect of the projected UK grid decarbonisation demonstrated that that the CO₂ emissions of the simulation model with maximum capacity CHP is at par with the simulation model without CHP around 2021, and even results in increased CO₂ emissions beyond 2021.

The high proportion of surplus electricity generated allows for CHP size reduction, while still retaining considerable economic and environmental benefit of a CHP. This can lower the capital cost of CHP installation and reduce complexities associated with exporting electricity. An approach to aid in the selection of the optimum CHP size based on an evaluation of the relationship between the main performance parameters (end use energy consumption, energy cost savings and CO₂ emissions) and their variation with CHP sizes was presented in this work. The result of the analysis indicated that the optimum CHP size based on economic and environmental considerations ranges from (525kWe to 460kWe), which is between 30% and 39% smaller than the maximum CHP size of 750kWe.

The energy performance result of the selected 307kWe CHP to be installed in the hotel was also presented. The result relative to the base model indicated that the end use energy consumption was reduced by 5%, with the CHP generated electricity closely matching the building's electricity demand. Additionally, the overall utility cost was reduced by 42% and a 21% reduction in CO₂ emissions, highlighting its environmental benefit and associated reduction in primary energy consumption despite the over 50% reduction in CHP size from 750kWe to 307kWe. Moreover, the result of the analysis of the effect of the projected UK grid decarbonisation established that that the CO₂ emissions of 307kWe CHP sized to avoid electricity export becomes less obvious from around 2022 relative to the simulation model without CHP and attains parity around 2026.

Chapter 8: Conclusions and Recommendations

8.1 Chapter Summary

An evaluation and implementation of energy and thermal performance improvements involves making informed strategic decisions which incorporates cost effective and sustainable environmental considerations. These decisions and enhancements should be knowledge based and sustainable, as they are intended to be long term strategic infrastructural investments. This research work undertook the evaluation of the impact of various technologies and measures on the energy efficiency and thermal performance of existing UK hotel buildings with the aid of holistic whole-building simulation models. These models were developed to perform thermal analysis that allowed for testing of the effects of various energy improvement measures on the energy efficiency and thermal performance of hotel buildings, especially as the simulation results are in formats that allow for the interrogation of individual systems/plant components. Therefore, the impact and interdependency of various energy saving technologies used to reduce energy consumption and improve energy efficiency in hotel buildings were considered. Moreover, the research examined how building energy parameters of occupancy pattern, energy consumption and building fabric can be modelled correctly in order to improve building energy efficiency, thermal performance and carbon emissions of existing UK hotel buildings.

This thesis includes four case studies, each of which was undertaken to present a practical approach of examining the holistic impact of the different installed energy improvement measures on the energy performance of the hotel building whilst also addressing the areas identified from the literature requiring further research, hence contributing to knowledge. These identified areas are:

1. Reduction of performance gap between estimated building energy consumption using dynamic simulation models and the actual site consumption, especially in hotel buildings (Chapter 4).
2. Impact of building façade, particularly double-skin façade and its cavity space ventilation on the thermal performance and the overall energy performance of existing hotel buildings (Chapter 5).
3. Impact of a glazing and glazing energy improvement retrofit on the energy performance of existing commercial buildings, especially hotels (Chapter 6).
4. Impact of CHP systems on the energy performance of existing UK hotel buildings and optimum size selection in CHP retrofitting (Chapter 7).

8.1.1 Case study 1: Estimation and validation of energy consumption in existing UK hotel buildings

This case study presented in chapter four is the first of the four case studies conducted, and it is aimed at developing a practical estimation and validation of the energy consumption of existing hotel buildings with relative accuracy. This study was necessitated due to the acknowledged performance gap that exists between estimated building energy consumption using dynamic simulation models and the actual building energy use especially as a relatively accurate estimate of the overall energy consumption in new and existing buildings is vital in the evaluation of building energy efficiency and CO₂ emission reduction strategies.

The findings of the study demonstrated that the use of energy simulation models that account for some unregulated energy use such as catering, which is substantial in hotels and which are also

not stringently subjected to building regulation or NCM methodologies (compliance models), can considerably improve the estimation of actual building energy consumption. Overall energy consumption estimation which is within 5% to 11% of the actual building energy use data was obtained for the case study buildings. In addition, the study demonstrated that such a model can provide energy consumption estimates that are up to 20% more accurate than building regulation compliance models. Therefore, the result of this study provides an indication of possible unregulated energy use that can be estimated to assist in the reduction of performance gaps for hotel buildings that have restaurants or high catering demands.

8.1.2 Case Study 2: Effect of DSF and its cavity space ventilation on the thermal and overall energy of existing hotel buildings

This study is the second case study, which is presented in chapter five. It was aimed at investigating the impact of extraction fans installed in the east and west DSF adjoining a central atrium on the thermal condition of the atrium and consequently the impact of this DSF ventilation on the overall energy consumption of the hotel building. The study considers the interaction between peculiar features and fabric of the building such as the influence of the DSF and the large central atrium, which can affect different building parameters (like ventilation, natural lighting, internal air quality, thermal comfort and energy use), particularly as appropriate consideration must be accorded to the design and operation of these peculiar features to ensure that their possible benefits are not negated.

This study was prompted owing to the problem of the prevailing high temperature found in the DSF cavity, giving rise to a high temperature in the atrium, thus increasing the cooling demand. Therefore, the possibility of installing extraction fans as a DSF ventilation strategy was evaluated

by this study as an alternative to increasing the capacity of the chillers, which consequently, has a considerable adverse effect of the overall energy consumption of the building. The results of the study indicated that the resultant temperature in the unventilated DSF cavity is substantially high, reaching up to 11°C above or below the central atrium temperature depending on the season. Hence, this temperature difference between the façade cavity and the central atrium space poses the risk of overheating and occupant discomfort particularly during the summer. However, the study result demonstrated that the installation of the extraction fans in the DSF improves the temperature and internal condition of the central atrium whilst only having a 0.2% marginal increase in the overall energy use of the building with the fan in operation throughout the year. Moreover, the marginal increment in overall energy consumption is eliminated with the fans operating only during the cooling dominant period (May to September).

The study also evaluated the impact of the DSF cavity model with the weather data of Edinburgh to evaluate the applicability of the DSF extraction fan ventilation in a relatively colder winter and milder summer climate zone of the UK. The Edinburgh simulation results indicated that the resultant temperature in the unventilated DSF cavity presents similar challenge of substantially high temperature of over 10°C above or below the central atrium temperature depending on season observed in the London weather simulation. Therefore, posing the risk of overheating and occupant discomfort particularly during the summer, which the results of the Edinburgh simulation also demonstrated that the installation of the extraction fans in the DSF operating during the summer improves the temperature and internal condition of the adjoining central atrium. Besides, the warmer prevailing temperature in the DSF cavity during the heating dominant period is more beneficial in the colder Edinburgh winter to reduce the heating load.

8.1.3 Case study 3: Impact of window films on the energy performance of existing UK hotel buildings

The third case study, presented in chapter six, evaluated the effect of a number of commercially available solar window films on the overall energy performance of UK operational hotel buildings using case studies of two different hotels with contrasting building façades and construction. The first case study building was primarily characterized by a single-skin glazed curtain wall structure with a comparatively high window to wall ratio while the second case study building was a mainly conventional building with a framed structure, cavity walling and double-glazed windows. Additionally, the case study also evaluated the impact of the films on the single-skin glazed curtain wall structure with the Edinburgh weather data to assess window films application in relatively colder UK locations.

The results of the study demonstrated that the impact of the evaluated solar window films on the total energy use of the case study buildings is not large, particularly for buildings with a conventional framed structure and wall façade. Moreover, for the case study building with mainly single glazed curtain wall in both London and Edinburgh weather data, a total energy saving range of approximately 1.2% to 2% was obtained, and this is primarily attributed to the reduction in cooling energy use. However, the study result demonstrated that even though the overall energy savings accruing from the window films is marginal; they have a considerable impact in the reduction of cooling energy consumption. This is evidenced by the up to 35% reduction in the annual cooling energy for the curtain wall building and a 17% reduction in the annual cooling energy consumption for the conventional framed structure and wall façade building.

Furthermore, analysis of the cost and GHG emissions also indicated that savings of up to 2% in utility cost and CO₂ emissions is possible with the application of the window films, particularly in the case of the glazed curtain wall building façade. Moreover, the result of this study indicates that the application of window films alone, especially in relatively large hotel buildings, cannot significantly reduce their overall energy consumption. Therefore, it can be more advantageous that they are used along with other energy efficiency improvement measures that can reduce the energy use of other components such as DHW and lighting, which constitute a significant part of the overall energy consumption. Nevertheless, other benefits of window films, including their potential of improving the internal thermal comfort of the building by reducing solar heat gain and glare, can make them a desirable retrofit option.

8.1.4 Case study 4: Optimum size selection of CHP retrofitting in existing UK hotel building

This study is the fourth case study, which is presented in chapter seven. It was aimed at evaluating the impact of CHP systems on the energy performance of existing UK hotel buildings and consequently, aid in the optimum size selection in CHP retrofitting. This was achieved by estimating the maximum CHP size to be retrofitted in an existing UK hotel building based on the heating demand of the hotel with a priority to satisfy the DHW demand and this was succeeded by a critical analysis of the economic and environmental benefits of reduced CHP capacity as criteria for the selection of the optimum CHP size to be retrofitted.

The result of the study demonstrated that CHP sized to the maximum capacity, particularly in large hotel buildings, can provide considerable environmental and economic benefits. As evidenced by the result of this case study, they can generate up to 50% off-grid electricity and provide over 50%

reduction in utility cost. The study results also demonstrated that CHP, either sized maximally or with a reduced capacity of more than 50% of the maximum size, can provide up to 21% reduction in CO₂ emissions. However, results of the evaluation of the ongoing decarbonisation of the UK power grid indicate that the environmental benefits of the natural gas-powered CHP is less pronounced for the future grid projections. Since the results demonstrated that the CO₂ emissions for the maximum capacity CHP, which delivers substantial surplus export electricity attains parity with the model without CHP around 2021, and even results in increased CO₂ emissions beyond 2021. Whereas, the CO₂ emissions of the simulation with the 307kWe CHP, sized to avoid electricity export becomes marginal from around 2022 relative to the model without CHP and attains parity around 2026. Furthermore, design of optimum CHP size can be obtained through evaluation of the relationship between the main performance parameters (end use energy consumption, energy cost savings and CO₂ emissions) and their variation with CHP sizes.

8.2 Limitations of the Studies in this Research

The limitations of this study are primarily attributed to the acknowledged difficulty in accurately replicating the exact thermal and energy performance of existing buildings, especially as some of the input data such as weather data and occupant behaviours are dynamic. Therefore, some assumptions were made in the thermal simulation software in the modelling of the thermal and energy performance of the hotel buildings. These assumptions have been acknowledged and delineated in the methodology section and include: the suitability of the CIBSE TRY weather data set, which is based on historic average data patterns over a certain number years to be applicable to the existing weather conditions of the locations of the case study buildings, utilisation of static U-values, and utilisation of NCM's standardised hotel internal conditions activity and occupancy,

which are similar to that of the case study, as the prevailing conditions of the case study hotel buildings. Moreover, there is also a limitation related to some assumptions made within simulation software to reduce the model complexity, as is usually the case with physical modelling tools.

8.3 Recommendations for Future Study

Some potential areas for future studies beyond the scope of this thesis which have been identified from gaps in existing state-of-the-art are presented in this section.

- **Reduction of the performance gap and validation of energy consumption in existing hotel buildings:** the results of this study and review of the existing literature have demonstrated the impact of the performance gap between building simulation models and actual building performance, especially as simulation models do not account for some unregulated energy use such as catering, which is significant in large hotel buildings. This work has provided an indication of possible unregulated energy use that can be estimated to aid in the reduction of performance gaps for hotel buildings that have restaurants or high catering demands. However, further studies and investigation are required in this area to accurately evaluate the catering energy consumption, including other unregulated energy use (such as lifts, small power loads and servers) using several and varied types of case study hotel buildings in other regions to validate the reduction performance gap. Additionally, the difficulties associated with accurate building energy consumption comparison and validation can be further improved by evaluation of the breakdown of actual building consumption into individual end use in several and varied types of case study hotel buildings, as this can deliver a better understanding of the energy consumption

component/end-uses that directly influence the differences between actual building energy consumption and building model.

- **Simplification of energy models:** the development of holistic whole building energy simulation models requires considerable data, technical know-how and time, particularly for large commercial buildings. In most cases, access to data for these buildings is difficult and often insufficient when access is gained. Therefore, it could be interesting for future studies to investigate and analyse holistic whole building models in order to reduce the required input data to few manageable core data that can be easily provided by a hotel operator on the characteristics of their property without compromising the accuracy of the models.

References

- 3M (2016) *Sun control film Technical data sheet*. Available at: http://solutions.3m.co.uk/wps/portal/3M/en_GB/3MWindowFilm/WindowFilm/Products/Pres-tige/ (accessed on 8 February 2017)
- Abdullah, A.H. (2007) *A Study on Thermal Environmental Performance in Atria in the Tropics with Special Reference to Malaysia*. PhD thesis. Heriot-Watt University.
- Action Energy (2004) *Combined heat and power for buildings*. Available at: <http://www.cwp-ltd.com/wp-content/uploads/2012/03/UKGoodPracticeGuide.pdf> (Accessed 16 September 2017)
- Ajla Aksamija (2017) 'Thermal and Energy Performance of Double Skin Facades in different climate types' *Proceedings of the PowerSkin Conference*. Delft University of Technology, The Netherlands, January 19th, 2017. Munich. TU Delft Open pp. 71-82
- Aldawoud, A. & Clark, R. (2008) Comparative analysis of energy performance between courtyard and atrium in buildings. *Energy and Buildings*, 40(3), pp.209–214.
- Allwood, C.M. (2012) The distinction between qualitative and quantitative research methods is problematic. *Quality & Quantity*, 46(5), p.1417-1429. *Summon* [Online]. Available at: <http://uwl.summon.serialssolutions.com> [Accessed 20 November 2015].
- Allouhi, A., El Fouih, Y., Kousksou, T., Jamil, A., Zeraouli, Y., Mourad, Y. (2015) Energy consumption and efficiency in buildings: Current status and future trends. *Journal of Cleaner*

Production, 109, pp.1–13. Available at:
<http://linkinghub.elsevier.com/retrieve/pii/S0959652615007581>.

Amara, F., Agbossou, K., Cardenas, A., Dubé, Y. and Kelouwani, S. (2015) ‘Comparison and Simulation of Building Thermal Models for Effective Energy Management’, *Smart Grid and Renewable Energy*, (April), pp. 95–112. doi: 10.4236/sgre.2015.64009.

Amber, K. P., Day, A. R., Ratyal, N. I., Ahmad, R., & Amar, M. (2018). The significance of a building’s energy consumption profiles for the optimum sizing of a Combined Heat and Power (CHP) system-A case study for a student residence hall. *Sustainability (Switzerland)*, 10(6).
<https://doi.org/10.3390/su10062069>

American Society of Heating Refrigerating and Air-conditioning Engineers, ASHRAE (2001) *Handbook Fundamentals 2001*, (Chapter 30: Fenestration). Available at:
<https://eclass.upatras.gr/modules/document/file.php/ARCH160/fenestration.pdf>. Accessed 08/02/2017

Amoako-Attah, J. (2015) *Impact of Climate Change on Newly Detached Residential Buildings in the UK Passive Mitigation and Adaptation Strategies*. PhD thesis. University of West London.

Amoako-Attah, J. & B-Jahromi, A. (2013) Impact of future climate change on UK building performance. *Advances in Environmental Research (AER): An International Journal of Interdisciplinary Research in Environmental Science, Technology, and Management Techno-Press.*, 2(3), pp.203-227.

Amoako-Attah, J. & B-Jahromi, A. (2014) Impact of standard construction specification on thermal comfort in UK dwellings. *Advances in Environmental Research (AER): An*

International Journal of Interdisciplinary Research in Environmental Science, Technology, and Management Techno-Press, 3(3), pp.253-281.

Amoako-Attah, J. and B-Jahromi, A. (2015) ‘Method comparison analysis of dwellings’ temperatures in the UK’, *Proceedings of the Institution of Civil Engineers: Engineering Sustainability*, 168(1), pp. 16–27. doi: 10.1680/ensu.14.00022.

Ander, G.D. (2014) *Windows and Glazing*. Available at: <https://www.wbdg.org/resources/windows.php> (Accessed: 5 November 2016).

Association of Decentralised Energy (2018c) *Imperial London Hotels case study*. Available at: <https://www.theade.co.uk/case-studies/building-chp/imperial-london-hotels> (Accessed: 14 September 2018).

Association of Decentralised Energy (2018b) *Radisson Hotel, Manchester case study*. Available at: <https://www.theade.co.uk/case-studies/building-chp/radisson-hotel-manchester> Accessed: 14 September 2018).

Association of Decentralised Energy (2018a) *Radisson Hotel Stansted Airport case study*. Available at: <https://www.theade.co.uk/case-studies/building-chp/radisson-hotel-stansted-airport> (Accessed: 14 September 2018).

Babaei, T., Abdi, H., Lim, C. P., and Nahavandi, S. (2015) ‘A study and a directory of energy consumption data sets of buildings’, *Energy and Buildings*. Elsevier B.V., 94, pp. 91–99. doi: 10.1016/j.enbuild.2015.02.043.

- Bahaj, A.S., James, P.A.B., and Jentsch, M.F., (2008), “Potential of emerging glazing technologies for highly glazed buildings in hot arid climates”, *Energy and Building*, 40, pp. 720-731.
- Barbieri, E. S., Spina, P. R. and Venturini, M. (2012) ‘Analysis of innovative micro-CHP systems to meet household energy demands’, *Applied Energy*. Elsevier Ltd, 97, pp. 723–733. doi: 10.1016/j.apenergy.2011.11.081.
- Barlow, S. & Fiala, D. (2007) Occupant comfort in UK Offices-How adaptive comfort theories might influence future low energy office refurbishment strategies. *Energy and Buildings*, 39(7), pp.837–846.
- Bilgen, S. (2014) ‘Structure and environmental impact of global energy consumption’, *Renewable and Sustainable Energy Reviews*. Pergamon, 38, pp. 890–902. doi: 10.1016/J.RSER.2014.07.004.
- Bhaumik, C.D. (2014) ‘Energy performance TM54 review – Fine tuning’ *CIBSE Journal* [Preprint]. Available at: <http://portfolio.cpl.co.uk/CIBSE/201410/energy-performance-tm54-review/> (Accessed: 15 September 2018).
- BRE (1988), “Exploiting sunshine in house design”, Eclipse Research Consultants, Building Research Establishment for the Department of Energy’s Energy Technology Support Unit.
- BRE (2000) *Carbon dioxide emissions from non-domestic buildings: 2000 and beyond*. United Kingdom: Construction Research Communications Ltd.

BRE, 2006. *Energy Performance of Buildings Directive*. pp.1–5. [online]. Available at: [http://www.bre.co.uk/filelibrary/Scotland/Energy_Performance_of_Buildings_Directive_\(EPBD\).pdf](http://www.bre.co.uk/filelibrary/Scotland/Energy_Performance_of_Buildings_Directive_(EPBD).pdf) (Accessed: 11 July 2016)

Çakir, U., Çomakli, K. and Yüksel, F. (2012) ‘The role of cogeneration systems in sustainability of energy’, *Energy Conversion and Management*, 63, pp. 196–202. doi: 10.1016/j.enconman.2012.01.041.

Carbon Bites (2016) *CIBSE TM 54 – Evaluating Operational Energy Performance of Buildings at the Design Stage*. Available at: <https://www.cibse.org/getmedia/2c7d1fa0-88d7-4c60-8876-6676500c9ceb/Carbon-Bites-TM54.pdf.aspx> (Accessed: 18 September 2018)

Carbon Trust (2018) *CRC Energy Efficiency Scheme*. Available at: <https://www.carbontrust.com/resources/guides/carbon-footprinting-and-reporting/crc-carbon-reduction-commitment/> (Accessed: 21 March 2018).

Carbon Trust (2013) *Energy efficiency in non-domestic buildings*. [online]. Available at: <https://www.carbontrust.com/news/2013/09/energy-efficiency-in-non-domestic-buildings/> (Accessed: 2 July 2016).

Carbon Trust (2010) *Introducing combined heat and power., Technology guide*. Available at: https://www.carbontrust.com/media/19529/ctv044_introducing_combined_heat_and_power.pdf <http://www.carbontrust.co.uk> (Accessed 16 September 2017)

Carbon Trust (2016a). *what exactly is science-based target?* Available at: <https://www.carbontrust.com/news/2016/08/what-exactly-is-a-science-based-target/> (Accessed: 21 September 2016).

- Carbon Trust (2016b) ‘*Why do we need to set science-based targets on climate change?*’, Available at: <https://www.carbontrust.com/news/2016/07/why-do-we-need-to-set-science-based-targets-on-climate-change/> (Accessed: 21 September 2016).
- Carriere, M., Schoenau, G. J. and Besant, R. W. (1999) ‘Investigation of some large building energy conservation opportunities using the DOE-2 model’, *Energy Conversion and Management*, 40(8), pp. 861–872. doi: 10.1016/S0196-8904(98)00152-6.
- Catalina, T., Virgone, J. and Blanco, E. (2008) ‘Development and validation of regression models to predict monthly heating demand for residential buildings’, *Energy and Buildings*, 40(10), pp. 1825–1832. doi: 10.1016/j.enbuild.2008.04.001.
- Cetiner, I. & Özkan, E. (2005) An approach for the evaluation of energy and cost efficiency of glass façades. *Energy and Buildings*, 37(6), pp.673–684.
- Chen, B., Ji, Y. and Xu, P. (2012) ‘Impact of Window Shading Devices on Energy Performance of Prototypical Buildings’, in *EPS*, 30, pp. 0-042
- CIBSE (2002) *Weather, solar and illuminance data. London: CIBSE Guide J.* London: Chartered Institution of Building Services Engineers.
- CIBSE (2005) *Climate change and the indoor environment: impacts and adaptation* CIBSE TM36. London: Chartered Institution of Building Services Engineers.
- CIBSE (2009a) *Use of climate change scenarios for building simulation: the CIBSE future weather years. CIBSE TM48.* London: Chartered Institution of Building Services Engineers.

CIBSE (2009b) *Energy efficiency in commercial kitchens* CIBSE TM50. London: Chartered Institution of Building Services Engineers.

CIBSE (2012) *Energy efficiency in buildings* CIBSE Guide F. London: Chartered Institution of Building Services Engineers.

CIBSE (2013a) *Evaluating operational energy performance of buildings at the design stage* *Evaluating operational energy performance of buildings at the design stage*. CIBSE TM54:2013. London: Chartered Institution of Building Services Engineers.

CIBSE (2013b) *Combined heat and power for buildings* CIBSE AM12. London: The Chartered Institution of Building Services Engineers.

CIBSE (2014) *Design Summer Years for London* CIBSE TM449. London: The Chartered Institution of Building Services Engineers.

CIBSE (2015a) *Building performance modelling*. CIBSE AM11. London: Chartered Institution of Building Services Engineers.

CIBSE (2015b) *CIBSE Case study: the advantages of TM 54*. Available at: <https://www.cibse.org/knowledge/knowledge-items/detail?id=a0q20000008JgWT> (Accessed: 19 September 2018).

Carbon Bites (2016) *CIBSE TM 54 – Evaluating Operational Energy Performance of Buildings at the Design Stage*. Available at: <https://www.cibse.org/getmedia/2c7d1fa0-88d7-4c60-8876-6676500c9ceb/Carbon-Bites-TM54.pdf.aspx> (Accessed: 18 September 2018)

CIBSE (2017) *CIBSE Weather Data sets* Available at: <http://www.cibse.org/knowledge/cibse-weather-data-sets> (Accessed: 17 July 2017)

Clean Energy News (2016) *Chancellor confirms the end of CRC* Available at: <https://www.cleanenergynews.co.uk/news/efficiency/chancellor-confirms-the-end-of-crc-7654> (Accessed: 29 March 2018).

Climate change act (2008) *Climate Change Act 2008* [Online]. Available at: <http://www.legislation.gov.uk/ukpga/2008/27/contents> [Accessed: 20 November 2015].

Cuce, E. & Riffat, S.B. (2015) A state-of-the-art review on innovative glazing technologies. *Renewable and Sustainable Energy Reviews*, 41, pp.695–714. Doi: <http://dx.doi.org/10.1016/j.rser.2014.08.084>.

Collins, L. (2012) Predicting annual energy consumption with thermal simulation: A UK perspective on mitigation of risks in estimation and operation. *Building Simulation*, 5(2), pp.117–125.

Committee on Climate Change (2017) *Meeting Carbon Budgets: Closing the policy gap: 2017 Report to Parliament*. Available at: <https://www.theccc.org.uk/wp-content/uploads/2017/06/2017-Report-to-Parliament-Meeting-Carbon-Budgets-Closing-the-policy-gap.pdf>. (Accessed: 8 October 2017).

Crawley, D.B., Hand, J.W., Kummert, M., Griffith, B.T. (2008) Contrasting the capabilities of building energy performance simulation programs. *Building and Environment*, 43(4), pp.661–673.

Creswell, J.W. (2014) *Research design: qualitative, quantitative, and mixed methods approaches*. 6th International student ed. Los Angeles: Sage publications.

Deng, S.M.; Burnett, J. (2000) Study of energy performance of hotel buildings in Hong Kong. *Energy Build*, 31, 7–12, doi:10.1016/S0378-7788(98)00067-X.

Department for Business, Energy and Industrial Strategy (2016) *Simple Guide to the CHP Quality Assurance (CHPQA) Programme*. Available at https://www.gov.uk/government/uploads/system/uploads/attachment_data/file/432578/Simple_Guide_to_the_CHP_Quality_Assurance.pdf (Accessed: 02 December 2017).

Department for Business, Energy & Industrial Strategy (2017a) *Combined Heat & Power Quality Assurance Programme*. Available at: <https://www.gov.uk/guidance/combined-heat-power-quality-assurance-programme#what-is-chpqa> (Accessed: 7 October 2017)

Department for Business, Energy and Industrial strategy (2017b) *Clean Growth Strategy*. Available at: <https://www.gov.uk/government/publications/clean-growth-strategy> (Accessed: 16 September 2018)

Department for Business, Energy and Industrial Strategy (2017c) *CHPQA Case Study University of Liverpool*. Available at: https://assets.publishing.service.gov.uk/government/uploads/system/uploads/attachment_data/file/605011/CHPQA_CS_Liverpool_University.pdf (Accessed on 15 September 2018).

Department for Business, Energy and Industrial Strategy (2017d) *CHPQA Case study Coventry District Energy Company*. Available at:

https://assets.publishing.service.gov.uk/government/uploads/system/uploads/attachment_data/file/589645/CHPQA_CS_CSWDC.pdf (Accessed on 15 September 2018).

Department for Business, Energy and Industrial strategy (2018a) *Updated energy and emissions projections 2017* Available at: https://assets.publishing.service.gov.uk/government/uploads/system/uploads/attachment_data/file/671187/Updated_energy_and_emissions_projections_2017.pdf (Accessed: 16 September 2018).

Department for Business, Energy and Industrial strategy (2018b) *UK Government Conversion Factors for greenhouse gas (GHG) reporting*. Available at: <https://www.gov.uk/government/publications/greenhouse-gas-reporting-conversion-factors-2018> (Accessed: 3 September 2018).

Department for Communities and Local Government (2015) *National Calculation Methodology (NCM) modelling guide (for buildings other than dwellings in England* 2013)* Department of Communities and Local Government.

Department for Environment Food and Rural Affairs (2018) *Clean Air Strategy 2018*. Available at: https://consult.defra.gov.uk/environmental-quality/clean-air-strategy-consultation/user_uploads/clean-air-strategy-2018-consultation.pdf (Accessed: 16 September 2018).

Department of Energy and Climate Change (2008b) *CHP Finance* Available at: <https://www.gov.uk/government/publications/combined-heat-and-power-chp-finance> (Accessed: 27 September 2017).

Department of Energy and Climate Change (2008a) *CHP Technology* Available at:
<https://www.gov.uk/government/publications/combined-heat-and-power-chp-technology>

(Accessed: 27 September 2017).

Dussault, J. M., Gosselin, L. and Galstian, T. (2012) ‘Integration of smart windows into building design for reduction of yearly overall energy consumption and peak loads’, *Solar Energy*. Elsevier Ltd, 86(11), pp. 3405–3416. doi: 10.1016/j.solener.2012.07.016.

Eames ME (2016) An update of the UK’s design summer years: probabilistic design summer years for enhanced overheating risk analysis in building design. *Journal of Building Services Engineering Research and Technology* 37(5): pp. 503–522.

EDSL TAS (2015a). *EDSL TAS* [online] Available at
<http://www.edsl.net/main/Software/Designer/NVandPD.aspx>. [Accessed 2 July 2015].

EDSL (2015b) *EDSL TAS Software* (version 9.3.3) [Computer program] Available at
<http://www.edsl.net/main/Software/EngineeringDownloads.aspx>

Encyclopedia Britannica (2009) *Stefan–Boltzmann law* Available at:
<https://www.britannica.com/science/Stefan-Boltzmann-law> (accessed: 9/3/2017)

European Union, On the Energy Performance of Buildings (2002). *Directive 2002/91/EC of the European Parliament and of the Council*. Official Journal of the European Communities, Brussels.

- Fallahi, A., Haghghat, F. and Elsadi, H. (2010) 'Energy performance assessment of double-skin facade with thermal mass', *Energy and Buildings*. Elsevier B.V., 42(9), pp. 1499–1509. doi:10.1016/j.enbuild.2010.03.020.
- Foucquier, A., Robert, S., Suard, F., Stéphan, L. and Jay, A. (2013) State of the art in building modelling and energy performances prediction: A review. *Renewable and Sustainable Energy Reviews*, 23, pp.272–288.
- Fumo, N. (2014) 'A review on the basics of building energy estimation', *Renewable and Sustainable Energy Reviews*. Elsevier, 31, pp. 53–60. doi: 10.1016/j.rser.2013.11.040.
- Gelesz, A., Reith, A. (2015) Climate-based performance evaluation of double skin facades by building energy modelling in Central Europe. *Energy Procedia*, 78, pp.555–560. Available at: <http://dx.doi.org/10.1016/j.egypro.2015.11.735>.
- General Electric (2018) *Combined Cycle Power Plant: How it Works*. Available at: <https://www.gepower.com/resources/knowledge-base/combined-cycle-power-plant-how-it-works> (Accessed 28 February 2018).
- Ghaffarianhoseini, A., Berardi, U., Tookey, J., Li, D. H. W. and Kariminia, S. (2016) 'Exploring the advantages and challenges of double-skin façades (DSFs)', *Renewable and Sustainable Energy Reviews*. Elsevier, 60, pp. 1052–1065. doi: 10.1016/j.rser.2016.01.130.
- Glass and Glazing Federation (2012) *Window film: application and solutions*. Available at: www.ggf.uk/windowfilm. (Accessed: 5 November 2016).

Gratia, E. and De Herde, A. (2004b) 'Natural cooling strategies efficiency in an office building with a double-skin façade', *Energy and Buildings*, 36(11), pp. 1139–1152. doi:10.1016/j.enbuild.2004.05.004.

Gratia, E. and De Herde, A. (2004a) 'Optimal operation of a south double-skin facade', *Energy and Buildings*, 36(1), pp. 41–60. doi: 10.1016/j.enbuild.2003.06.001.

Ground Source Heat Pump Association (2018) *2018 Decarbonisation update implications for Heat Pumps* Available at: [https://www.gshp.org.uk/Decarbonisation Update 2018.html](https://www.gshp.org.uk/Decarbonisation%20Update%202018.html) (Accessed: 16 September 2018).

Gucyeter, B. and Gunaydin, H.M. (2012) Optimization of an envelope retrofit strategy for an existing office building. *Energy and Buildings*, 55(2012), pp.647–659.

Hee, W.J., Alghoul, M. A., Bakhtyar, B., Elayeb, O., Shameri, M. A., Alrubaih, M. S. and Sopian, K. (2015) The role of window glazing on daylighting and energy saving in buildings. *Renewable and Sustainable Energy Reviews*, 42, pp.323–343. Available at: <http://dx.doi.org/10.1016/j.rser.2014.09.020>.

Hien, W. N., Liping, W., Chandra, A. N., Pandey, A. R. and Xiaolin, W. (2005) 'Effects of double glazed facade on energy consumption, thermal comfort and condensation for a typical office building in Singapore', *Energy and Buildings*, 37(6), pp. 563–572. doi: 10.1016/j.enbuild.2004.08.004.

Holmes, M.J. and Hacker, J.N. (2007) Climate change, thermal comfort and energy: Meeting the design challenges of the 21st century. *Energy and Buildings*, 39(7), pp.802–814.

Høseggen, R., Wachenfeldt, B.J. and Hanssen, S.O. (2008) Building simulation as an assisting tool in decision making. Case study: With or without a double-skin façade? *Energy and Buildings*, 40(5), pp.821–827.

Huang, Y., Niu, J. lei and Chung, T.M. (2014) Comprehensive analysis on thermal and daylighting performance of glazing and shading designs on office building envelope in cooling-dominant climates. *Applied Energy*, 134, pp.215–228. Available at: <http://dx.doi.org/10.1016/j.apenergy.2014.07.100>.

Hygh, J.S., DeCarolis, J.F., Hill, D.B. and Ranjithan, S.R. (2012) Multivariate regression as an energy assessment tool in early building design. *Building and Environment*, 57, pp.165–175. Available at: <http://dx.doi.org/10.1016/j.buildenv.2012.04.021>.

Ihara, T., Gustavsen, A. and Jelle, B.P. (2015) Effect of facade components on energy efficiency in office buildings. *Applied Energy*, 158, pp.422–432. Available at: <http://dx.doi.org/10.1016/j.apenergy.2015.08.074>.

Intergovernmental Panel on Climate Change (2007) *Climate Change 2007: Synthesis Report. Contribution of Working Groups I, II and III to the Fourth Assessment Report of the Intergovernmental Panel on Climate Change* [Core Writing Team, Pachauri, R.K and Reisinger, A. (eds.)]. IPCC, Geneva, Switzerland.

International Energy Agency (2013a) *Redrawing the Energy Climate Map – World Energy Outlook Special report*. Available at: https://www.iea.org/publications/freepublications/publication/WEO_Special_Report_2013_Redrawing_the_Energy_Climate_Map.pdf (Accessed: 18 October 2017)

International Energy Agency (2013b) *Transition to Sustainable Buildings - Strategies and opportunities to 2050*. Available at:

http://www.iea.org/publications/freepublications/publication/Building2013_free.pdf%5Cnw.w.iea.org/etp/buildings (Accessed: 23 October 2017)

International Energy Agency (2008) *Combined Heat and Power-Evaluating the benefits of greater global investment*. Paris, France: IEA. Available at:

https://www.iea.org/publications/freepublications/publication/chp_report.pdf. (Accessed: 9 November 2017)

International Energy Agency (2016) *World Energy Outlook 2016*. Available at:

<https://www.iea.org/Textbase/npsum/WEO2016SUM.pdf> (Accessed: 19 October 2017).

International Energy Agency (2015) *World Energy Outlook Special Report 2015: Energy and Climate Change*. Available at:

<https://www.iea.org/publications/freepublications/publication/WEO2015SpecialReportonEnergyandClimateChange.pdf> (Accessed: 18 February 2018).

Jaberansari, M. and Elkadi, H. (2016) 'Influence of different atria types on energy efficiency and thermal comfort of square plan high - rise buildings in semi - arid climate', *International conference on Energy, Environment and Economics*. August 16–18.

Jenkins, D., Banfill, P. and Pellegrini-Masini, G. (2009) *Non-domestic conclusions of the Tarbase project-Reducing CO2 emissions of existing buildings*. Heriot-Watt University, Edinburgh, UK. Available at: www.sbe.hw.ac.uk/research/ibud/urban-energy/research-projects.htm.

Juan, Y.K., Gao, P. and Wang, J. (2010) A hybrid decision support system for sustainable office building renovation and energy performance improvement. *Energy and Buildings*, 42(3), pp.290–297.

Kelly, K. A., McManus, M. C., & Hammond, G. P. (2014). An energy and carbon life cycle assessment of industrial CHP (combined heat and power) in the context of a low carbon UK. *Energy*, 77, 812–821. <https://doi.org/10.1016/j.energy.2014.09.051>

Kendrick, C., Ogden, R., Wang, X. and Baiche, B. (2012) Thermal mass in new build UK housing: A comparison of structural systems in a future weather scenario. *Energy and Buildings*, 48, pp.40–49. Available at: <http://dx.doi.org/10.1016/j.enbuild.2012.01.009>.

King, D., Browne, J., Layard, R., O'Donnell, G., Rees, M., Stern, N. and Turner, A., (2015). *A global Apollo programme to combat climate change*. Centre for Economic Performance, London School of Economics and Political Science. http://cep.lse.ac.uk/pubs/download/special/Global_Apollo_Programme_Report.pdf [accessed 9 October 2016].

Kneifel, J. (2010) Life-cycle carbon and cost analysis of energy efficiency measures in new commercial buildings. *Energy and Buildings*, 42(3), pp.333–340.

Knight, I., Stravoravdis, S. and Lasvaux, S. (2008) Predicting operational energy consumption profiles - Findings from detailed surveys and modelling in a UK educational building compared to measured consumption. *International Journal of Ventilation*, 7(1), pp.49–57.

- Langner, M.R., Gregor, P.H., Corbin, C.D., and Brandemuehl, M.J. (2012) An investigation of design parameters that affect commercial high-rise office building energy consumption and demand. *Journal of Building Performance Simulation* 5(5), pp. 313-328.
- Leedy, P.D. and Ormrod, J.E. (2010). *Practical Research Planning and Design*. 9th ed. Boston: Pearson.
- Leedy, P.D. and Ormrod, J.E. (2015). *Practical Research Planning and Design*. 11th ed. Boston: Pearson.
- Li, C., Tan, J., Chow, T.-T. and Qiu, Z. (2015) ‘Experimental and theoretical study on the effect of window films on building energy consumption’, *Energy and Buildings*. Elsevier B.V., 102, pp. 129–138. doi: 10.1016/j.enbuild.2015.04.025.
- Low Carbon Innovation Coordination Group LCICG report (2012) *Technological Innovation Needs Assessments: Non-Domestic buildings summary report*. Available at: <https://www.carbontrust.com/media/218006/tina-non-domestic-buildings-energy-efficiency-summary-report.pdf> (Accessed 5 November 2016)
- Mago, P.J. and Smith, A.D. (2012) Evaluation of the potential emissions reductions from the use of CHP systems in different commercial buildings. *Building and Environment*, 53, pp.74–82. Available at: <http://dx.doi.org/10.1016/j.buildenv.2012.01.006>.
- Menezes, A.C., Cripps, A., Bouchlaghem, D. and Buswell, R. (2012) Predicted vs. actual energy performance of non-domestic buildings: Using post-occupancy evaluation data to reduce the

performance gap. *Applied Energy*, 97, pp.355–364. Available at: <http://dx.doi.org/10.1016/j.apenergy.2011.11.075>.

Met Office (2017) *State of UK climate*. Available at: <https://www.metoffice.gov.uk/climate/uk/about/state-of-climate> (Accessed: 20 September 2018)

Mustafaraj, G., Marini, D., Costa, A. and Keane, M. (2014) Model calibration for building energy efficiency simulation. *Applied Energy*, 130, pp.72–85. Available at: <http://dx.doi.org/10.1016/j.apenergy.2014.05.019>.

Mylona Anastasia (2017) *Revision of Design Summer years and Test Reference Years* Available at: <http://www.cibse.org/getmedia/cc70f2d9-8ef8-42cb-83ce-2316546f0aa0/Introduction-to-CIBSE-Weather-Data-Files.pdf.aspx> (Accessed: 17 July 2017).

National Energy Efficiency Action Plans NEEAPs (2017) *28 April 2017: UK 2017 National Energy Efficiency Action Plan and Annual Report*. Available at: https://ec.europa.eu/energy/sites/ener/files/documents/uk_neeap_2017.pdf (Accessed 16 January 2018)

Nicholas, W. (2010) *Research Methods: The Basics*. [online]. Routledge. Available at: <<http://www.mylibrary.com?ID=304249>> (Accessed: 3 March 2017)

Nock, A., Ojiako, U., Bektas, T. and Chipulu M. (2012) ‘CHP and its role in efficient energy production: a feasibility assessment model’, *Management of Environmental Quality: An International Journal*, 23(5), pp. 546–565. doi: 10.1108/14777831211255123.

- Office of Gas and Electricity Markets (2017) *Feed-In Tariff (FIT) rates*. Available at: <https://www.ofgem.gov.uk/environmental-programmes/fit/fit-tariff-rates> (Accessed: 1 December 2017)
- Olivier J.G.J., Janssens-Maenhout G., Muntean M. and Peters J.A.H.W. (2016) *Trends in global CO2 emissions; 2016 Report*. The Hague: PBL Netherlands Environmental Assessment Agency; Ispra: European Commission, Joint Research Centre.
- Parra, J., Guardo, A., Egusquiza, E. and Alavedra, P. (2015) ‘Thermal Performance of Ventilated Double Skin Façades with Venetian Blinds’, *Energies*, 8(6), pp. 4882–4898. doi: 10.3390/en8064882.
- Poirazis, H. (2004) *Double Skin Façades for Office Buildings Literature Review*. Lund University.
- Plummer, J.R. (2015) *Window film: A cost effective window retrofit*. Available at: <http://www.greenbuildermedia.com/buildingscience/window-film-a-cost-effective-window-retrofit> (Accessed: 3 November 2016).
- Priyadarsini, R.; Xuchao, W.; Eang, L.S. (2009) A study on energy performance of hotel buildings in Singapore. *Energy Build*, 41, 1319–1324, doi:10.1016/j.enbuild.2009.07.028.
- Punch, K. (2005) *Introduction to social research: quantitative and qualitative approaches*. 2nd ed. London: Sage Publications Ltd.
- Roberts, S. (2008) Altering existing buildings in the UK. *Energy Policy*, 36(12), p.4482-4486.

Rodríguez, C. G., Andrés, C. A., Muñoz, F. D., López, J. M. C., Zhang, Y. (2013) Uncertainties and sensitivity analysis in building energy simulation using macro parameters. *Energy and Buildings*, 67, pp.79–87.

Romero Rodríguez, L., Lissen, S. M. J., Ramos, S. J., Jara Roriguez, A. E. and Dominguez, A. S. (2016) ‘Analysis of the economic feasibility and reduction of a building’s energy consumption and emissions when integrating hybrid solar thermal/PV/micro-CHP systems’, *Applied Energy*, 165, pp. 828–838. doi: 10.1016/j.apenergy.2015.12.080.

Royal Commission on Environmental Pollution (2000) *Royal Commission on Environmental Pollution report* [Online]. Available at: <http://www.nirs.org/climate/background/ukroyalcommclimatechange6152000.htm> [Accessed: 23 November 2015].

Salem, R., Bahadori-Jahromi, A., Mylona, A., Godfrey, P., & Cook, D. (2018). Comparison and evaluation of the potential energy, carbon emissions, and financial impacts from the incorporation of CHP and CCHP systems in existing UK hotel buildings. *Energies*, 11(5), 1–15. <https://doi.org/10.3390/en11051219>

Saunders, M., Lewis, P. & Thornhill, A. (2016) *Research methods for business students*. 7th ed. Harlow: Pearson Education limited.

Schiermeier, Q. (2011) ‘Clean-energy credits tarnished’, *Nature*, 477(7366), pp. 517–518. doi: 10.1038/477517a.

- Smith, A. D., Mago, P. J. and Fumo, N. (2013) ‘Benefits of thermal energy storage option combined with CHP system for different commercial building types’, *Sustainable Energy Technologies and Assessments*, 1(1), pp. 3–12. doi: 10.1016/j.seta.2012.11.001.
- Smith, J. B. Schneider, S. H., Oppenheimer, M., Yohe, G.W., Hare, W., Mastrandrea, M.D., Patwardhan, A., Burton, I., Corfee-Morlot, J., Magadza, C.H.D., Füssel, H., Pittock, A.B., Rahman, A., Suarez, A., Ypersele V.J., (2009) ‘Assessing dangerous climate change through an update of the Intergovernmental Panel on Climate Change (IPCC) “reasons for concern”’, *Proceedings of the National Academy of Sciences*, 106(11), p. 4133 LP-4137. Available at: <http://www.pnas.org/content/106/11/4133>.
- Sorgato, M. J., Melo, A. P. and Lamberts, R. (2016) ‘The effect of window opening ventilation control on residential building energy consumption’, *Energy and Buildings*. Elsevier B.V., 133, pp. 1–13. doi: 10.1016/j.enbuild.2016.09.059.
- Spitz, C., Mora, L., Wurtz, E. and Jay, A. (2012) Practical application of uncertainty analysis and sensitivity analysis on an experimental house. *Energy and Buildings*, 55, pp.459–470. <http://dx.doi.org/10.1016/j.enbuild.2012.08.013>
- Taylor, S., Peacock, A., Banfill, P. and Shao, L. (2010) Reduction of greenhouse gas emissions from UK hotels in 2030. *Building and Environment*, 45(6), p.1389-1400.
- UK Climate Projections (2010) *UK Climate Projections 2009 Weather Generator User Interface* [Online]. Available at: <http://ukclimateprojections-ui.metoffice.gov.uk/ui/start/start.php> [Accessed: 23 November 2015].
- UNEP-SBCI (2009) *Sustainable Buildings and Climate initiative, Building*. Available at: <http://www.unep.org/sbci/AboutSBCI/Background.asp>. (Accessed: 23 October 2017)

UNFCCC (2014) *First steps to a safer future: Introducing The United Nations Framework Convention on Climate Change* Available online: http://unfccc.int/essential_background/convention/items/6036.php Accessed 18 September 2017

UNFCCC (2015) *Historic Paris Agreement on Climate Change* [Online]. Available at: <http://newsroom.unfccc.int/unfccc-newsroom/finale-cop21/> [Accessed: 20 December 2015].

United States Environmental Protection Agency EPA (2016) *Climate Change Indicators: Atmospheric concentration of GHG*. Available online: <https://www.epa.gov/climate-indicators/climate-change-indicators-atmospheric-concentrations-greenhouse-gases>. Accessed 19 September 2017.

United States Environmental Protection Agency Combined Heat and Power Partnership (2015) *Catalog of CHP Technologies*. Available online: https://www.epa.gov/sites/production/files/2015-07/documents/catalog_of_chp_technologies_section_1_introduction.pdf Accessed 21 November 2017.

United States Environmental Protection Agency EPA (2018) *Combined Heat and Power (CHP) Partnership*. Available online: <https://www.epa.gov/chp/what-chp>. Accessed 26 March 2018.

Vanhoutteghem, L., Skarning, G. C. J., Hviid, C. A. and Svendsen, S. (2015) 'Impact of façade window design on energy, daylighting and thermal comfort in nearly zero-energy houses', *Energy and Buildings*. Elsevier B.V., 102, pp. 149–156. doi: 10.1016/j.enbuild.2015.05.018.

- Virk, D. & Eames M. (2016) *CIBSE Weather Files 2016 release: Technical Briefing and Testing*. Available at: http://www.cibse.org/getmedia/ce7a77e8-3f98-4b97-9dbc-7baf0062f6c6/WeatherData_TechnicalBriefingandTesting_Final.pdf.aspx (Accessed: 17 July 17, 2017)
- Wada, K., Akimito, K., Sano, F., Oda, J. and Homma, T. (2012) ‘Energy efficiency opportunities in the residential sector and their feasibility’, *Energy*. Elsevier Ltd, 48(1), pp. 5–10. doi: 10.1016/j.energy.2012.01.046.
- Wang, J.C. (2012) A study on the energy performance of hotel buildings in Taiwan. *Energy Build*, 49, 268–275, doi:10.1016/j.enbuild.2012.02.016.
- Wang, L. and Greenberg, S. (2015) ‘Window operation and impacts on building energy consumption’, *Energy and Buildings*. Elsevier B.V., 92, pp. 313–321. doi: 10.1016/j.enbuild.2015.01.060.
- World Meteorological Organisation (2013) *A summary of current climate change findings and figures*: World Meteorological Organisation.
- Xing, J.; Ren, P.; Ling, J. (2015) Analysis of energy efficiency retrofit scheme for hotel buildings using eQuest software: A case study from Tianjin, China. *Energy Build*. 87, 14–24, doi:10.1016/j.enbuild.2014.10.045.
- Yang, Q., Liu, M., Shu, C., Mmereki, D., Uzzal Hossain, M. and Zhan, X. (2015) ‘Impact Analysis of Window-Wall Ratio on Heating and Cooling Energy Consumption of Residential Buildings

in Hot Summer and Cold Winter Zone in China’, *Journal of Engineering (United States)*, 2015(October). doi: 10.1155/2015/538254.

Yin, R., Xu, P. and Shen, P. (2012) ‘Case study: Energy savings from solar window film in two commercial buildings in Shanghai’, *Energy and Buildings*. Elsevier B.V., 45, pp. 132–140. doi: 10.1016/j.enbuild.2011.10.062.

Yousif, K. M. (2012) ‘Control of Solar Heat Gain to Reduce the Energy Consumption of Buildings in Iraq’, in Proc. of World Renewable Energy Forum, pp. 1–8.

Zhao, H. X. and Magoulès, F. (2012) ‘A review on the prediction of building energy consumption’, *Renewable and Sustainable Energy Reviews*. Elsevier Ltd, 16(6), pp. 3586–3592. doi: 10.1016/j.rser.2012.02.049.