



## **UWL REPOSITORY**

**repository.uwl.ac.uk**

Understanding feedback and feed-forward: insights drawn from project-based learning

Rizzuto, Joseph and Balodimou, Efcharis ORCID: <https://orcid.org/0000-0003-1249-3941> (2019)  
Understanding feedback and feed-forward: insights drawn from project-based learning. In: Festival of Learning and Teaching, 3 July 2019, Ealing, London. (Unpublished)

**This is the Presentation of the final output.**

**UWL repository link:** <https://repository.uwl.ac.uk/id/eprint/6408/>

**Alternative formats:** If you require this document in an alternative format, please contact: [open.research@uwl.ac.uk](mailto:open.research@uwl.ac.uk)

### **Copyright:**

Copyright and moral rights for the publications made accessible in the public portal are retained by the authors and/or other copyright owners and it is a condition of accessing publications that users recognise and abide by the legal requirements associated with these rights.

**Take down policy:** If you believe that this document breaches copyright, please contact us at [open.research@uwl.ac.uk](mailto:open.research@uwl.ac.uk) providing details, and we will remove access to the work immediately and investigate your claim.

# Understanding feedback and feedforward: Insights drawn from project-based learning

Joseph Rizzuto and Efcharis Balodimou

School of Computing and Engineering

Civil Engineering and Built Environment

03 July 2019

# Summary

- Introduction
- Project Based Learning (PBL)
- Group work in PBL
- Effective Feedback
- Feedforward
- Case Study 1 – Level 5
- Case Study 2 – Level 6
- Conclusions

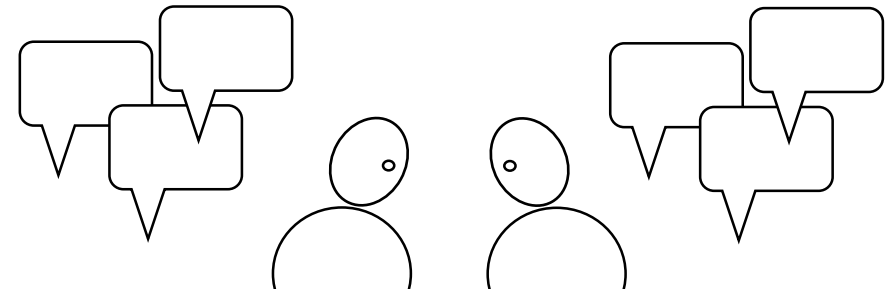

*Image: JR.*

# 1.0 Introduction

- Feedback plays an integral role in the success of **Project-based learning**.
- Important that students recognise when feedback is being provided and that it is **constructive**; not just backward-looking.
- **Feedback** should include explanations on aspects of the work which are relevant to subsequent assessments (HEA, 2013; Doughney, 2014).
- Focusing on particular factors helps feedback to function as **feedforward** for future work (Nicol and Macfarlane-Dick, 2006).

## 2.0. Project Based Learning (PBL)

- **PBL** is an **active and dynamic pedagogy** where students learn by enacting and solving real case scenarios involving, in our case, the design and construction of buildings and infrastructure.
- The student output expected in **PBL** requires **thinking** and **creativity** focussed on seeking satisfactory solutions which are usually balanced against client needs (Adams *et.al.*, 2011).
- Assessment tasks in PBL need to be carefully defined to ensure they allow for **personal decision making** and also cover **learning outcomes** (Saidani and Rizzuto, 2000; May, 2009).

## 2.1. Group work in PBL

- Project-based design modules mostly involve **group work** which leads to enhanced communication and the development of inter-personal skills (HEA, 2013).
- **Assessment** in PBL is often via **group** and **individual** submissions.
- **Reflection** is required on group interaction and progression (Choi and Kim, 2016; Royalty, 2017).
- Individual submission is set to determine each student's overall contribution.

## 2.2 Effective Feedback

- Students rely on **good quality, effective and timely** feedback to identify areas in which they are doing well and areas in need of development (QAA, 2018).
- Students' understanding of the **feedback** they receive is therefore very important.
- **Feedback** is seen as an activity that helps accelerate student learning.
- Continual discourse creates a positive educational environment which enhances student performance and outcome.

## 2.3 PBL Feedforward

- Feedforward is important especially when there are two or more linked assessments.
- Feedback is positively used as feedforward to help develop the next assignment.

**We will now look at two case studies involving PBL, feedback and feedforward.**

- Case study 1– Level 5, Built Environment – Integrated construction Project
- Case study 2– Level 6, Civil Engineering, Structural design Project



# 3.0 Case Study 1

## Level 5 – Integrated Construction project

This is a **two semester** interdisciplinary module that includes students from three degree courses: (i) Architectural Design and Technology, (ii) Building Surveying and (iii) Construction Project management.

**First semester:** students work in mixed **groups** of 4-6 to produce a feasibility study and outline design for a student accommodation building.

**Second semester:** they develop the project **individually** focusing on their specific discipline professional roles.

# **3.1 Assignments**

## **Assessment 1: S1 - Group work**

Proposal required for student accommodation simulating a real life scenario. Interpretation of a client's brief is required together with understanding the various stages of the design and construction processes.

## **Assessment 2: S2 - Individual work**

Each student further develops the project from Assessment 1 individually relevant to their Course discipline.

# 3.2 Assessment and feedback

Assessment 1: Group work – 40% weighting

Site analysis and feasibility (weeks 1-6)



Brief, conceptual and outline design (weeks 7-13)



Wk 6 - Interim presentation



Wk 14 - Group Submission 1

Formative and summative (15% weighting):

Tutor and peer feedback from presentation used to develop work further (feedforward)



**Formative:** Group tutorials and oral feedback on a weekly basis throughout the semester.

Formative and summative (25% weighting)

# 3.3 Assessment and feedback

Assessment 2: Individual work (60% weighting)

Materials and Environmental issues (All)

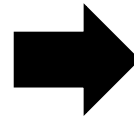

Site management / health and safety (CPM and BS)

Detailed design and Specification (ADT)

S2 WK 6 – General topics

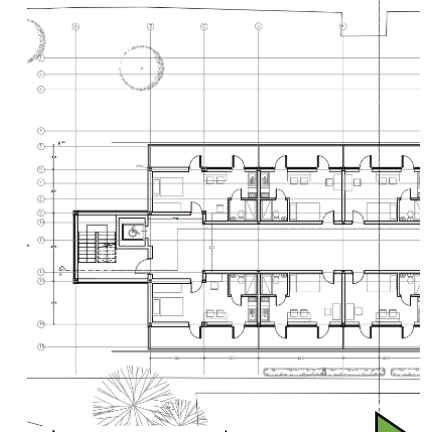
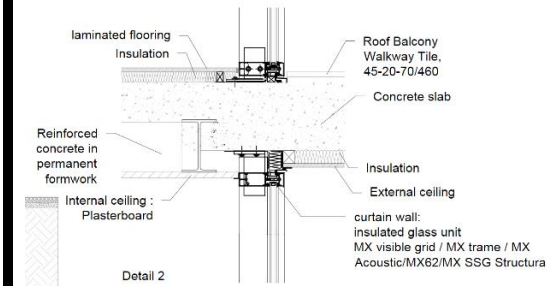
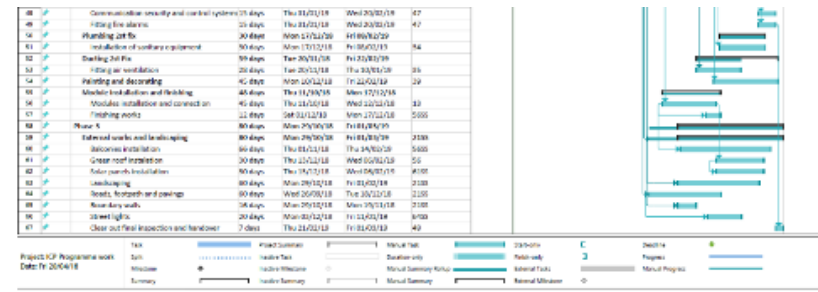

S2 WK 14 – Final Submission 2

Summative and formative written feedback

Formative: 1-1 tutorials and oral feedback on a weekly basis throughout the semester.

# 3.4 Feedback

## Complexity

- Group and individual feedback
- Feedback on report writing and processes
- Feedback on Graphical content and Design
- Feedback for multidisciplinary content

### 1. Formative/Oral Feedback:

Throughout the term in groups and 1-2-1 tutorials

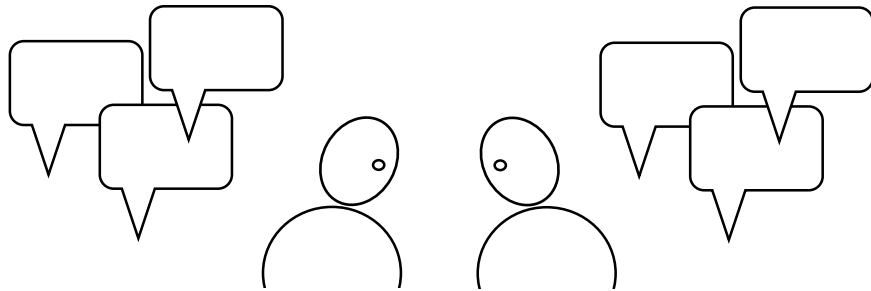
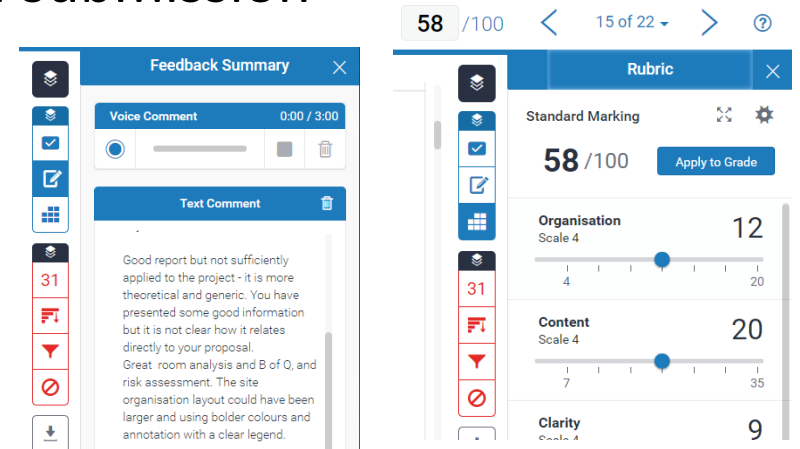

Image: JR.

### 2. Formative/Summative :

at key milestones i.e. Presentations and final submission



**3. Feedforward:** Essential when two assignments are linked or after interim presentation to enable students to develop their work.

# 4.0 Case Study 2

## Level 6 – Structural Design Project

This is a semester 1 Civil Engineering module. Students work in groups of 3-6 students to produce three report submissions (2 No Group and 1 No individual work).

### Assignments are:

- **Part 1 – Conceptual Design Report (Group Work - 40%)**
- **Part 2 – Final Analysis & Design Report (Group Work - 40%)**
- **Part 3 – Individual Report (20%)**

# 4.1 Assignments

## **Part 1 – Conceptual Design**

Students working in groups aim to produce at least two distinct and workable concept solutions for the structures of the building. One of the concepts is recommended to the client.

## **Part 2 –Analysis & Design of recommended solution**

For the recommended scheme selected in 1 (accordingly modified) final design calculations supported by annotated, scaled and dimensioned drawings are submitted by the groups.

## **Part 3 – Individual Report**

Individuals reflect on group dynamics and delegation of work. Problems and difficulties encountered and how these were overcome to be addressed.

# 4.2 Assessment and feedback

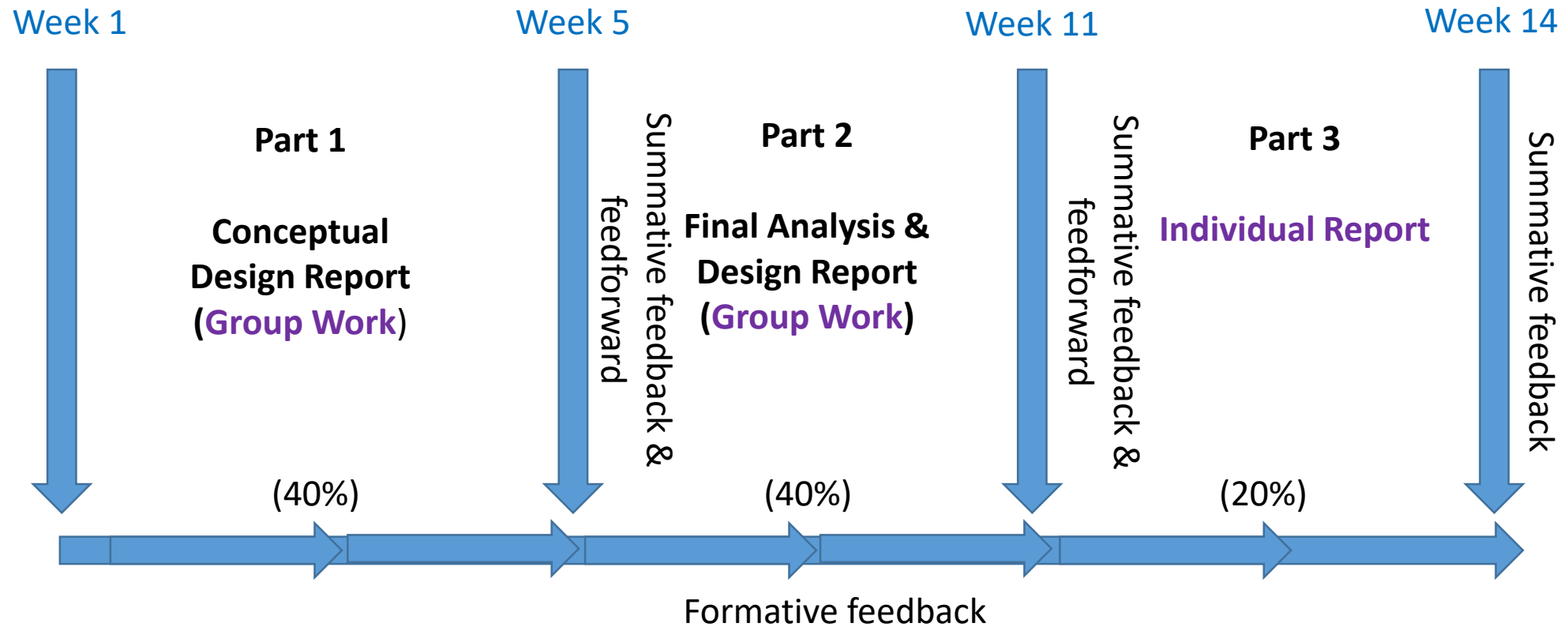



# 4.3 Development of a new Headquarters office building

A single-storey fully glazed restaurant area is required with a minimum number of internal columns. The structure is to be exposed and aesthetically pleasing.

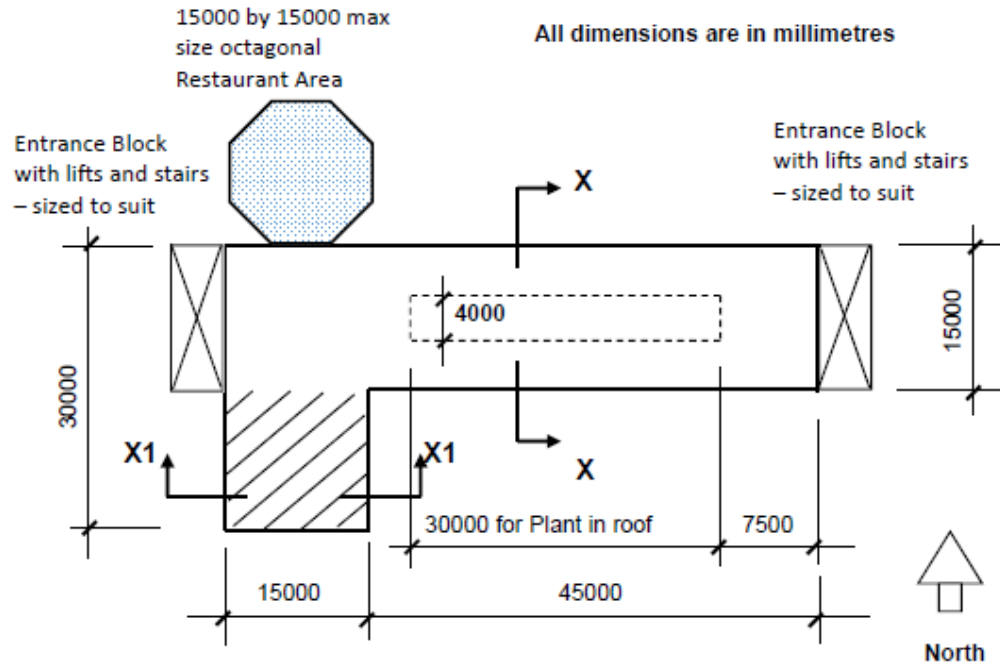

**OFFICE BUILDING - PLAN**  
(Not to scale)

Shaded area of the shorter return requires to be free of any internal partitions and any columns at ground floor level whilst still maintaining the floor depth limits.

Internal partitions are not load bearing but one line only of internal columns is acceptable on either of the lines of the internal partitions.

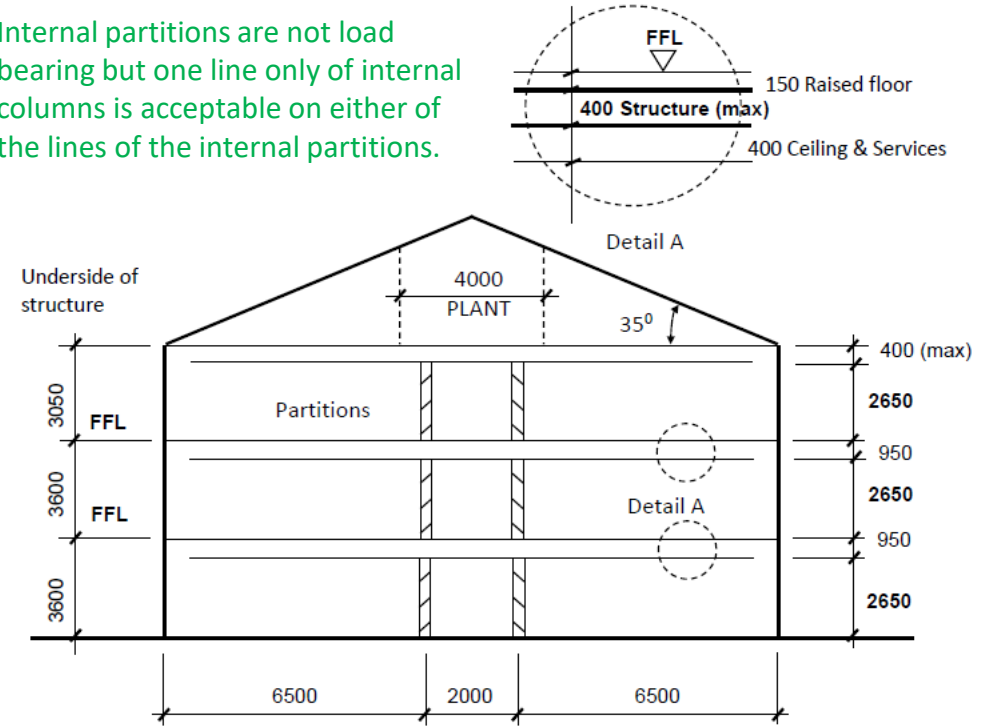

**SECTION X – X**

(SECTION X1 - X1 similar but with no Plant in the roof space or partitions/columns at Ground floor level)

**OFFICE BUILDING**  
(Not to scale)

# 4.4 Part 1 - Conceptual design

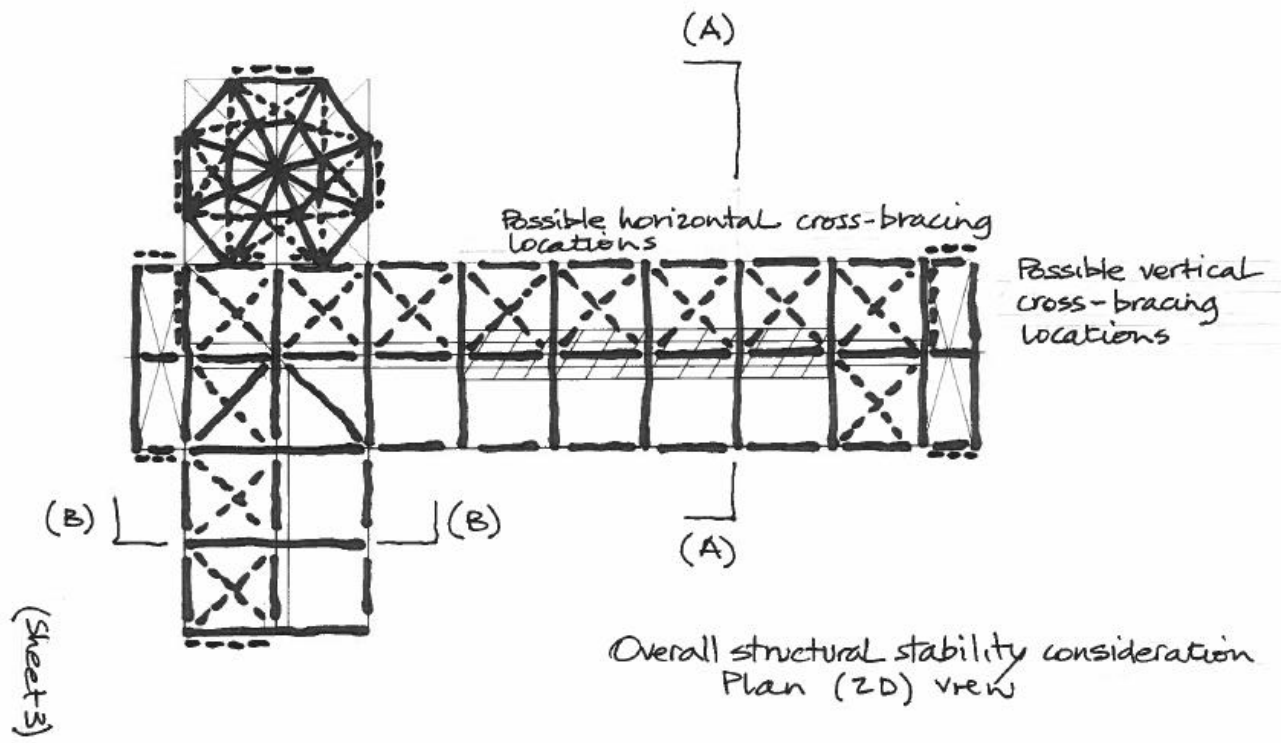
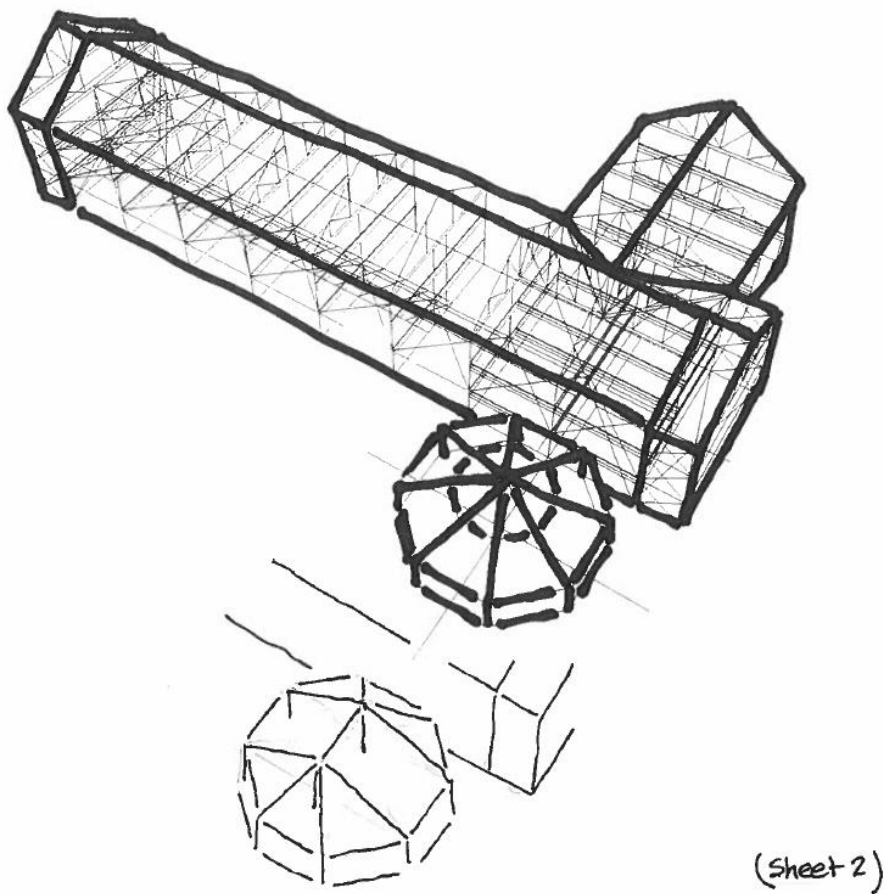

# 4.4 Part 1 - Conceptual design

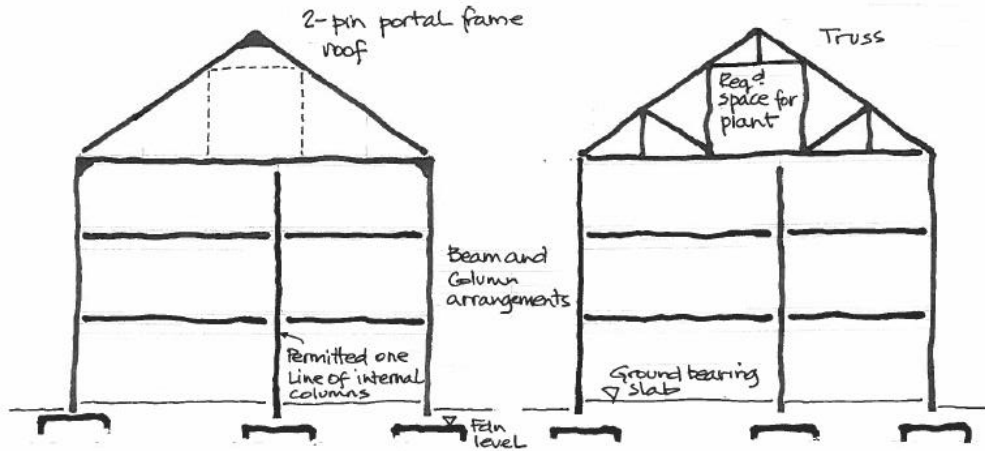

Possible elevations - Section (A-A)  
(See sheet 2)

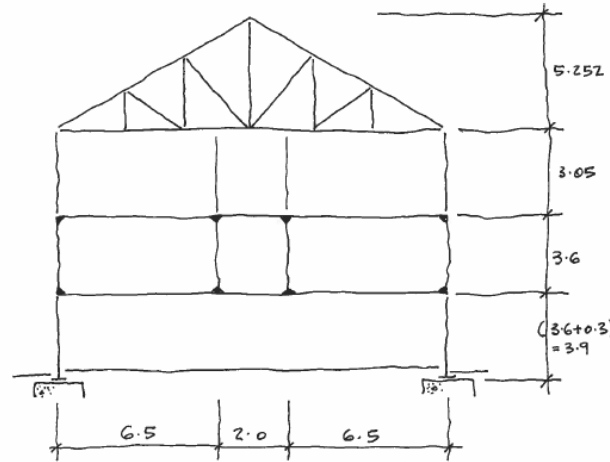

Alternative Viereckel Girder Arrangement  
(See sheet 2 for location)  
Section (B-B)

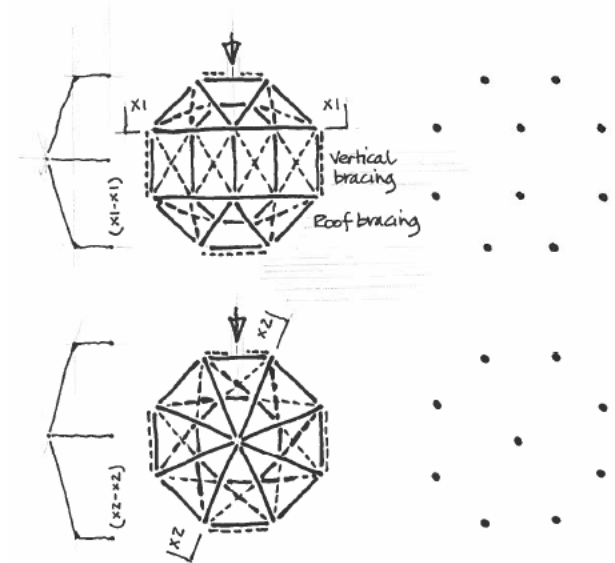

(Sheet 5)

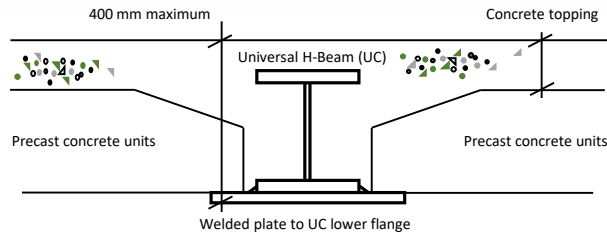

Non-composite floor slab support detail  
(not to scale)

# 4.5 Part 2 - Recommended Final design

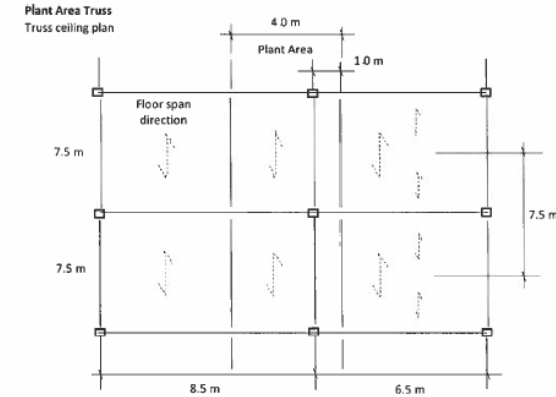
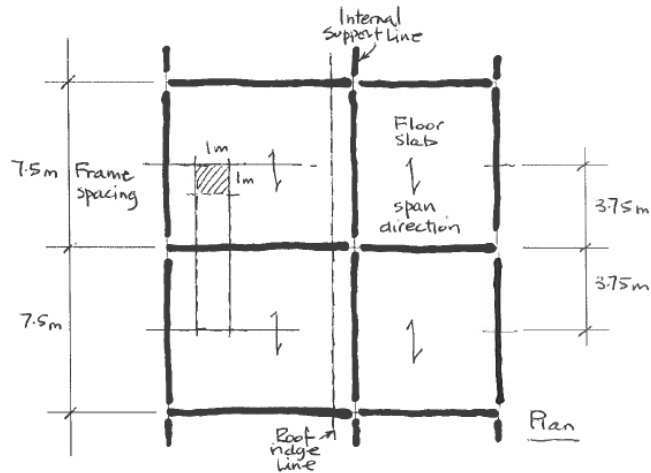
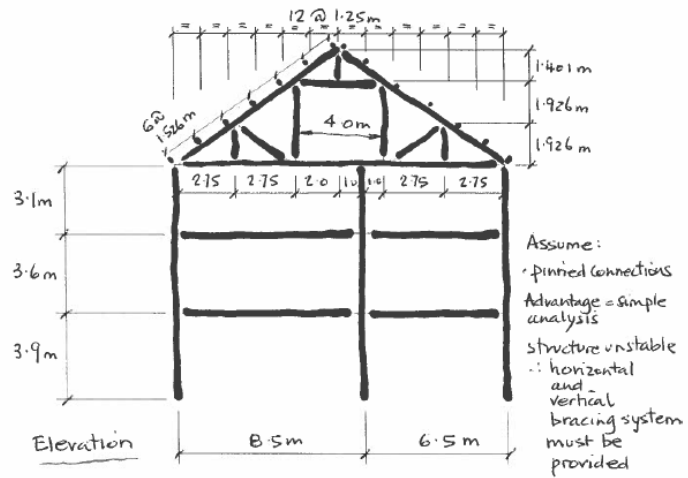

**Basic Load Cases**

LC	Description	Load	Allow (say) 0.43 + 15% = 0.50 kN/m run
1	DL SWT	(Self-weight + 15%)	
2	DL Roof covering	1.10 kN/m <sup>2</sup>	
3	DL PC floor slabs	3.00 kN/m <sup>2</sup>	
4	IL Roof	0.60 kN/m <sup>2</sup>	
5	IL Ceiling Plant Area	5.0 kN/m <sup>2</sup>	
6	IL Ceiling	0.75 kN/m <sup>2</sup>	
7	WL Roof	+ve 0.8 kN/m <sup>2</sup> , -ve 0.8 kN/m <sup>2</sup>	

Assume purlins at 1.25m (on plan) centres

LC	Description	Load	Value	Notes
1	DL SWT	(Self-weight + 15%)	0.50 kN/m run	
2	DL Roof covering	1.10 kN/m <sup>2</sup>	10.30 kN	Pt load
3	DL PC floor slabs	3.00 kN/m <sup>2</sup>	22.50 kN/m run	Beam loads
4	IL Roof	0.60 kN/m <sup>2</sup>	5.63 kN	Pt load
5	IL Ceiling Plant Area	5.0 kN/m <sup>2</sup>	37.50 kN/m run	Beam loads
6	IL Ceiling	0.75 kN/m <sup>2</sup>	5.63 kN/m run	Beam loads
7	WL Roof	+ve 0.8 kN/m <sup>2</sup> , -ve 0.8 kN/m <sup>2</sup>	+ve 7.50 kN -ve 7.50 kN	Pt load
		$x = 7.50 \text{ kN} \sin 35^\circ =$ $z = 7.50 \text{ kN} \cos 35^\circ =$	4.30 kN +ve 6.14 kN -ve, +ve	Pt load

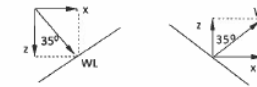

**Combination load cases**

Case	Load Combination
CLC1	Max BM, V, N
CLC2	Max delta
CLC3	Max wind

$1.35A1 + 1.35A2 + 1.35A3 + 1.50A4 + 1.50A5 + 1.50A6$   
 $1.0A4 + 1.0A5 + 1.0A6$   
 $1.0A1 + 1.0A2 + 1.0A3 + 1.50A7$

# 4.6 Part3 - Individual Report

Fig.1. Plan example

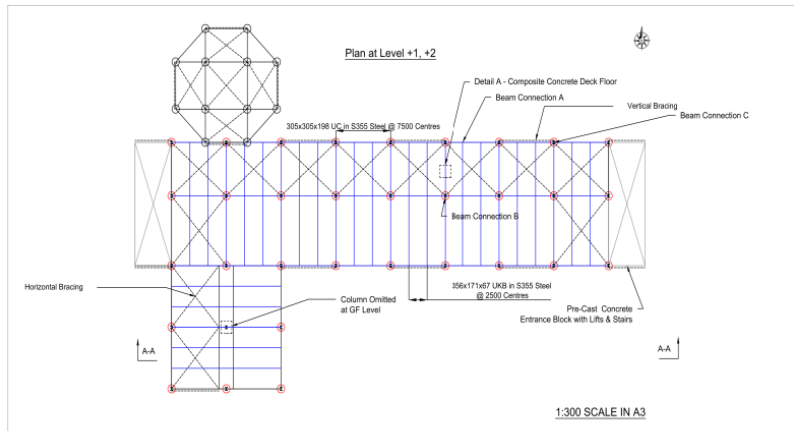

*Image acknowledgment:  
BEng H Civil Engineering, Structural Design project Module, semester 1, 2018 – 2019 submission*

Student  
individual  
submission

## Part 3 - Individual Report

### Areas for consideration:

- Conceptual design required at least two different structural concepts for the development.
- Consider the importance of ensuring the appointing of a person as the project leader from the start of the project to coordinate the tasks and group workload.
- Create sub-teams to determine and coordinate sub-tasks.
- Consider the importance of making use of technology such as SharePoint group folders, Skype video conferencing and WhatsApp groups all to help with remote communication.
- Consider hand analysis methods (possibly making use of spreadsheets) in the first instance and as a starting point as an alternative to the immediate use of analysis software.
- Consider that the Project provides the opportunity to experience a complex and realistic design scenario.
- Consider that the Project design scenario provides a unique learning opportunity in teamwork.
- Project scenario provides the opportunity for the development of employability graduate skills such as leadership, teamwork, communication, critical thinking and problem solving.
- Recognise that there are a number of challenges to group work that includes unequal participation, easy for someone to avoid work, time consuming, everyone's work requires to be double checked for correctness, personality clashes and inaccurate and late individual contributions.
- Appoint someone to take responsibility for merging files together for group submissions.
- Recognise that when working with others, things do not always go to plan and allowance should be made for this.
- Ensure a clear chain of effective and constructive communication established, for example, between the calculations teams and the CAD teams.
- Recognise the importance of being able to explain ideas and intentions using a variety of means including drawings, sketches, calculations and written reports containing good use of English together with good presentation of material.
- Do not be reluctant or shy to ask for help when necessary.
- Consider client's requirements and project limitations including construction methods to be used.
- Consider appropriate choice of materials.
- Provide detailed discussion of the technical solutions that were arrived at and why.
- Provide design assumptions statements.
- Functional framing sketches - structures should be idealised to show how they function and work.
- Critical review of framing options.
- Structural schemes sufficiently illustrated.
- Load paths and load transfer mechanisms correctly identified, for example, explain how the loads and actions on the structure are transferred from the point of application to the supporting ground.
- Overall stability considerations of the scheme. Structures should be designed to resist lateral forces in two orthogonal directions and applied forces resolved for other wall directions.
- Structural behaviour prediction understood and demonstrated.

Feedback  
given by  
tutor

# 4.7 Feedback

- Complexity:**
- Group and individual feedback
  - Feedback on conceptual and recommended solutions
  - Feedback on report writing skills
  - Feedback on individual submission

## 1. Formative/Oral Feedback:

Throughout the semester in groups and 1-to-1 tutorials

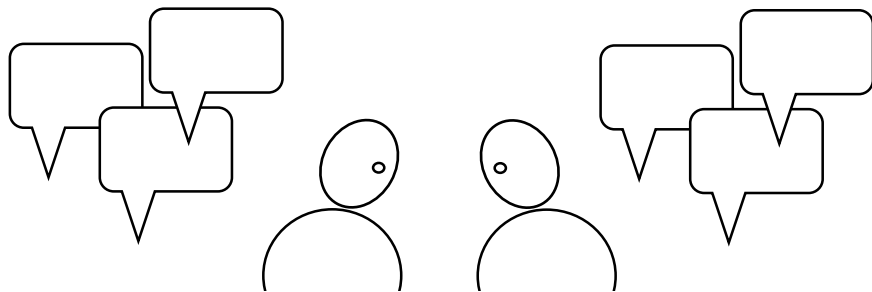
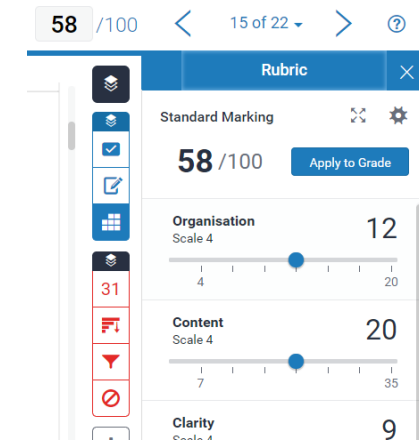

Image: JR.

## 2. Formative/Summative : at key milestones i.e. three submissions



## 3. Feedforward: Essential when two assignments are linked to enable students to develop their work.

# 5.0 Conclusions

- Feedback plays an integral role in the success of Project-based learning.
- Important that students recognise when feedback is being provided and that it is constructive; not just backward-looking.
- Feedback should include explanations on aspects of the work which are relevant to subsequent assessments.
- Feedforward important especially when there are two or more linked assessments.

# References

- Adams, R.S., Daly, S.R, & Mann, L.M (2011) Being a professional: Three lenses into design thinking, acting and being. *Design Studies* 32(6) November 2011.
- Choi, H.H. & Kim, M.J. (2016) The effects of analogical and metaphorical reasoning on design thinking. *Thinking skills and Creativity* 23: 29-41.
- Doughney, L. (2014) *Providing effective feedback to students*. Centre for the Study of Higher Education, University of Melbourne. Available at: [https://arts.unimelb.edu.au/data/assets/pdf\\_file/0004/1722397/providing-effective-feedback-to-students.pdf](https://arts.unimelb.edu.au/data/assets/pdf_file/0004/1722397/providing-effective-feedback-to-students.pdf)
- Higher Education Academy. (2013) *HEA Feedback toolkit*. Available at: [https://www.heacademy.ac.uk/system/files/resources/feedback\\_toolkit\\_whole1.pdf](https://www.heacademy.ac.uk/system/files/resources/feedback_toolkit_whole1.pdf)
- Higher Education Academy (2014) *Assessment and feedback. Teaching International Students Project*. Available at: [https://www.heacademy.ac.uk/system/files/resources/assessment\\_and\\_feedback.pdf](https://www.heacademy.ac.uk/system/files/resources/assessment_and_feedback.pdf)
- May, I.M (2009) What should we teach in structural engineering design. *ICE Proceedings, Civil Engineering*, 162:187-191.
- Nicol, D.J & Macfarlane-Dick (2006) Formative assessment and self-regulated learning; a model and seven principles of good feedback practice. *Studies in Higher Education*, 3(2):199-218.
- Quality Assurance Agency - QAA (2018). *UK quality code for higher education. Advice and Guidance; Assessment*. UK Standing Committee for higher education.
- Royalty, A. (2017) Design based pedagogy; Investigating an emerging approach to teaching design to non-designers. *Mechanism and Machine theory* 125.
- Saidani, M. & Rizzuto, J.P. (2000) Engineering Design Assisted by physical Models, *Proc. Int. Colloquium on Structural Morphology* Delft, The Netherlands, The International Association for Shell and Spatial Structures: 422-426.